

Committed to Providing Quality Products
with the Best Service

Uflow[®]
Automation
INDIA

Automation
Simplified...

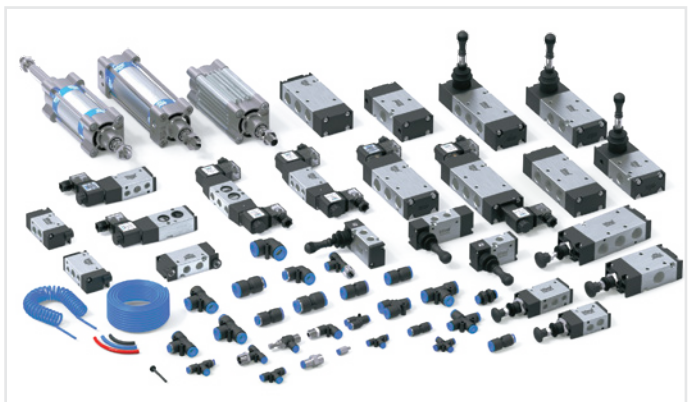

Solenoid Valve Industrial Valve Pneumatic

Country of Origin - INDIA





COMPANY PROFILE

Uflow Automation is an engineering organization committed to providing complete solutions to customer's requirements. We are established in the year 2007 and progressing with a vision of applying finest engineering practices in valve manufacturing industry by our restless and high skilled **ENGINEERS**, standard organizational **PROCESSES** and superior quality **PRODUCTS**.

We are a leading solenoid valve manufacturing company in India, known as **UFLOW**, our range of products includes - Pilot Operated Diaphragm Type Valves, Pneumatically Control Valves, Gas Solenoid valves, High Pressure Valves, Industrial Valves, Pneumatic Directional Control Valves, Rotary Coupling and Actuators. Our products are sold across INDIA and being exported outside India in various other countries.

Our Quality	Our Commitment	About Us
<ul style="list-style-type: none"> <input checked="" type="checkbox"/> In-House full scale testing facility. <input checked="" type="checkbox"/> Lean manufacturing practices / six sigma, kaizen, 5S. <input checked="" type="checkbox"/> Certified by : ISO 9001:2015 (TUV Nord), CE, ERDA, CIMFR, BIS, PESO. 	<ul style="list-style-type: none"> <input checked="" type="checkbox"/> To understand customer's need first before proposing our products. <input checked="" type="checkbox"/> To keep on providing competitive rate's by adapting to continuous process improvement, without compromising on quality. <input checked="" type="checkbox"/> To provide continuous support to our customers and go beyond their expectations in terms of delivery and after sale services. 	<ul style="list-style-type: none"> <input checked="" type="checkbox"/> In house R&D, manufacturing and testing facility is all located in a single premise at Rajkot Gujarat India. <input checked="" type="checkbox"/> Authorized channel partners in 20 different states in India. <input checked="" type="checkbox"/> Sales office in the UAE, Germany, Chile, Australia (Expanding).

We started building our products for a specific market segment and over the period of time we progressed to built it for various sectors that includes:

- | | | | | | |
|---|---|--|---|--|--|
| <input checked="" type="checkbox"/> Textile | <input checked="" type="checkbox"/> Water Treatment | <input checked="" type="checkbox"/> Energy & Power | <input checked="" type="checkbox"/> Packaging | <input checked="" type="checkbox"/> Pharmaceutical | <input checked="" type="checkbox"/> Oil & Gas |
| <input checked="" type="checkbox"/> Nuclear | <input checked="" type="checkbox"/> Marine | <input checked="" type="checkbox"/> Chemical | <input checked="" type="checkbox"/> Food and Beverage | <input checked="" type="checkbox"/> Steel & Cement | <input checked="" type="checkbox"/> Automotive |

We stand amongst the pioneers of the industry because of our following competitive advantages:

- Total quality management allow us to maintain the quality of our products,
- We follow genuine customer relationship policy and that help us to build trusted relationships.
- We believe in timely delivery and consistent quality standard, and this is possible due to the state of the art testing facility, that ensures our customers don't have any complains.
- Innovative products range with sophisticated and latest technology.
- Qualified customer service team, facilitate with the customers to resolve their respective query. Also feel free to ask for our customer references and product samples.

Uflow's Quality control is based on the platform of stringent process control by elimination of production variances; by a computerized integrated system we are able to guarantee the quality of products, and by recording each production step to ensure effective data analysis as well as a complete and efficient traceability of both components and finished products. This practice helps us in maintaining standards of high competitiveness in the marketplace.

Note: *For Any Other Information Contact Uflow.
* All Information may change without prior notice.

Index

Pneumatic DCC Series	7
Pneumatic DCS Series	13
3/8" Manifold for 1/4"	19
1/2" Manifold for 1/2"	20
Pneumatic Tie Rod Cylinder - CS4 Series (As Per ISO 15552 / VDMA 24562 Standards)	23
Pneumatic Cylinder Double End Double Acting - CS4 Series (As Per ISO 15552 / VDMA 24562 Standards)	25
Pneumatic Tie Rod Cylinder - CN4 Series (As per ISO 6431 / CETOP RP43P, RP53P standards)	28
Pneumatic Cylinder Double End Double Acting - CN4 Series (As per ISO 6431 / CETOP RP43P, RP53P standards)	29
PU Pneumatic Tie Rod Cylinder - PS4 Series (As Per ISO 15552 / VDMA 24562 Standards)	31
PU Pneumatic Cylinder Double End Double Acting - PS4 Series (As Per ISO 15552 / VDMA 24562 Standards)	33
PU Pneumatic Tie Rod Cylinder - PN4 Series (As per ISO 6431 / CETOP RP43P, RP53P standards)	35
PU Pneumatic Cylinder Double End Double Acting - PN4 Series (As per ISO 6431 / CETOP RP43P, RP53P standards)	36
Pneumatic Profile Cylinder - CS7 Series (As Per ISO 15552 / VDMA 24562 Standards)	38
Pneumatic Profile Cylinder Double End Double Acting - CS7 Series (As Per ISO 15552 / VDMA 24562 Standards)	39
PU Pneumatic Profile Cylinder - PS7 Series (As Per ISO 15552 / VDMA 24562 Standards)	41
PU Pneumatic Profile Cylinder Double End Double Acting - PS7 Series (As Per ISO 15552 / VDMA 24562 Standards)	42
Air Cylinder Mounting Bracket	44
Air Cylinder Accessories	46
Compact Cylinder - CP Series	47
Miniature Air Cylinder Magnetic And Non-Magnetic - MXC Series	50
Air Filter - PD Series	54
Air Regulator - PD Series	55
Air Lubricator - PD Series	56
Filter Regulator Combination - PD Series	57
FRL UNIT - PD Series	58
FRCL UNIT - PD Series	60
High Pressure Regulator - PB Series	66
High Pressure Regulator - DR Series	68

Index

One Touch Fittings - VO Series	71
Flow Controller - VF Series	80
Plastic Tubings	84
3/2 Single Solenoid Poppet Valve (NC / NO) - DCP Series	92
5/2 Single Solenoid Directional Control Poppet Valve (Monostable) - DCP Series	93
3/2 X 5/2 Convertible Single Solenoid Directional Control Namur Poppet Valve (Monostable) - DCP Series	94
5/2 Double Solenoid Directional Control Poppet Valve (Bistable) - DCP Series	95
3/2 Single Solenoid Directional Control Poppet Valve (NC / NO) - DCP Series	96
3/2 Single Solenoid Namur Poppet Valve (NC) - DCP Series	97
3 Way Direct Acting Namur Poppet Type Valve - DCP Series	98
3 Way Direct Acting Poppet Type Valve (Universal) - DCP Series	99
3 Way Direct Acting Poppet Type Valve (Universal) - DCP Series	100
3/2 Single And Dual Pressure Blow Solenoid Poppet Valve (NC) - DCP Series	101
5x2 Double Solenoid Directional Control Hybrid Poppet Valve - DCI Series	104
Shuttle OR Valve - SH Series	106
Shuttle AND Valve - SH Series	107
Pilot Operated Diaphragm Type Solenoid Valve (NC / NO) - PCN Series	110
Pilot Operated Diaphragm Type Solenoid Valve (NC) - PBN Series	112
High Pressure Pilot Operated Diaphragm Type Solenoid Valve (NC) - PBU Series	114
Semi Lift Diaphragm Operated Solenoid Valve (NC / NO) - MCN Series	116
Semi Lift Diaphragm Operated Plastic Solenoid Valve (NC) - MNN Series	118
Pilot Operated Piston Type Solenoid Valve (NC / NO) - HCP Series	120
Pulse Jet Angle Type Dust Collector Valve (NC) - JAN Series	122
External Pilot Operated Pulse Jet Angle Type Dust Collector Valve - EPS Series	124
Gas Solenoid Valve - UGS Series	126
2/2 Way Direct Acting Solenoid Valve (NC / NO) - DAS Series	128
3/2 Way Direct Acting Solenoid Valve (NC / NO) - DAS Series	131
2/2 Way Direct Acting Solenoid Valve (NC / NO) - DAC Series	133

Index

3/2 Way Direct Acting Solenoid Valve (NC / NO) - DAC Series	136
2/2 Solenoid Valve For Terminal / Gantry Automation (NC / NO) - DAR Series	140
2/2 Way Direct Acting Angle Type Valve (NC) - DAA Series	142
2 Way Direct Acting Media Separated Solenoid Valve (NC)	144
2/2 Way Direct Acting Auto Drain Solenoid Valve (NC)	146
2/2 Way Pilot Operated Auto Drain Solenoid Valve (Normally Close)	147
Pinch Type Solenoid Valve (NC / NO)	150
2/2 Way Control Valve With Aluminum Operated Valve (NC)	152
Solenoid Coils	155
Angle Seat Valve with Plastic Actuator Operated - ACP Series	161
Angle Seat Valve with Steel Actuator Operated (NC / NO) - YCP Series	165
3 Way Control Valve (NC / NO) - TCP Series	167
Rotary Quarter Turn Pneumatic Actuator - AD & AS Series	171
Screwed / Socket Weld Ball Valve - JC Series	178
3 Piece Flange Ball Valve - JC Series	179
Butterfly Valve Wafer Type - BW Series	182
Butterfly Valve Lug Type - BL Series	187
Micro Limit Switch - LC & LS Series	193
Roto Seal Coupling - UCV Series	197
External Pilot Operated With Solenoid On Off Valve (NC / NO) - ENN Series	200
2 Way - 3 Way Direct Acting Pilot Solenoid Valve (NC / NO) - DAP Series	202
Pilot Operated Diaphragm Type Plastic Solenoid Valve with Flow Controller (NC) - PNN Series	204
Proportional Flow Control Solenoid Valve - MINI (Low Flow) - PVL Series	207
Proportional Flow Control Solenoid Valve - MAX (High Flow) - PVH Series	209
3/2 Way Direct Acting Universal Valve (NC / NO) - UMV Series	211



PNEUMATIC VALVE SERIES

Model Information

Type:	Solenoid Operated, Lever Operated, Pilot Air Operated, Push Pull (3X2-NC / NO, 5X2, 5X3)
Design:	Spool Type & Cartridge Type (DCC Series)
Media:	Compressed Air (Filtered & Lubricated)
Working Pressure Range:	2 - 10 Bar for Solenoid Valve 0 - 10 Bar for Manual Valve & Air Pilot Valve
Ambient / Media Temperature:	5°C - 60°C
Materials of Construction:	Aluminium, Nitrile, Brass, Polymer

Coil Information

Coil Width :	26 mm
Coil Bore :	10 mm
Voltage (V) ± 10% :	AC (50Hz, 60Hz) - 24V, 110V, 230V DC 12V, 24V, 36V, 48V, 110V
Power Consumption :	AC-6W, DC-6W
Duty Cycle :	Continuous
Class of Insulation :	Class H
Type of Coil Protection :	IP65
Coil Housing :	Epoxy Square Coil

FEATURES

- Cartridge Type Design For Long Life
- Compact Design
- Standard NAMUR Mounting
- 1 Million Cycle Tested
- Low Power Consumption
- Manual Override
- Lubrication Not Essential
- Wide Range Of Coil Voltage

3X2, 5X2 Single solenoid valve with spring return



1 - Input, 2/4 - Output, 3/5 - Exhaust

Model No.	Flow (at 6 Bar)	Port Size			Function	Symbol
		In	Out	Exh		
DCC-B1V1	1200 LPM	¼"	¼"	¼"	Spring Return (NC)	
DCC-A1V1	1200 LPM	¼"	¼"	¼"	Spring Return (NO)	
DCC-D1V1	1200 LPM	¼"	¼"	⅝"	Spring Return	
DCC-B2V1	3500 LPM	½"	½"	½"	Spring Return (NC)	
DCC-A2V1	3500 LPM	½"	½"	½"	Spring Return (NO)	
DCC-D2V1	3500 LPM	½"	½"	½"	Spring Return	

3X2, 5X2 Double solenoid valve



1 - Input, 2/4 - Output, 3/5 - Exhaust

Model No.	Flow (at 6 Bar)	Port Size			Function	Symbol
		In	Out	Exh		
DCC-C1V1	1200 LPM	¼"	¼"	¼"	Double Solenoid	
DCC-E1V1	1200 LPM	¼"	¼"	⅝"	Double Solenoid	
DCC-C2V1	3500 LPM	½"	½"	½"	Double Solenoid	
DCC-E2V1	3500 LPM	½"	½"	½"	Double Solenoid	

3X2, 5X2 Single solenoid namur valve with spring return



1 - Input, 2/4 - Output, 3/5 - Exhaust

Model No.	Flow (at 6 Bar)	Port Size			Function	Symbol
		In	Out	Exh		
DCC-J1RV1	1200 LPM	¼"	Namur	¼"	3X2 Spring Return	
	1200 LPM	¼"	Namur	¼"	5X2 Spring Return	

3X2, 5X2 Double solenoid namur valve

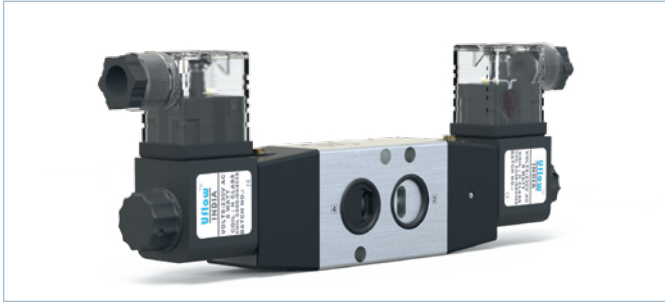

1 - Input, 2/4 - Output, 3/5 - Exhaust

Model No.	Flow (at 6 Bar)	Port Size			Function	Symbol
		In	Out	Exh		
DCC-K1RV1	1200 LPM	¼"	Namur	¼"	3X2 Double Solenoid	
	1200 LPM	¼"	Namur	¼"	5X2 Double Solenoid	

5X3 Double solenoid valve with spring center



1 - Input, 2/4 - Output, 3/5 - Exhaust

Model No.	Flow (at 6 Bar)	Port Size			Function	Symbol
		In	Out	Exh		
DCC-F1V1	1200 LPM	¼"	¼"	⅝"	Center Blocked	
DCC-G1V1	1200 LPM	¼"	¼"	⅝"	Center Exhausted	
DCC-H1V1	1200 LPM	¼"	¼"	⅝"	Center Pressurised	
DCC-F2V1	3500 LPM	½"	½"	½"	Center Blocked	
DCC-G2V1	3500 LPM	½"	½"	½"	Center Exhausted	
DCC-H2V1	3500 LPM	½"	½"	½"	Center Pressurised	

3X2 Hand lever valve manual and spring return



1 - Input, 2/4 - Output, 3/5 - Exhaust

Model No.	Flow (at 6 Bar)	Port Size			Function	Symbol
		In	Out	Exh		
DCC-LB1V1	1200 LPM	¼"	¼"	¼"	Spring Return(NC)	
DCC-LZ1V1	1200 LPM	¼"	¼"	¼"	Spring Return(NO)	
DCC-LC1V1	1200 LPM	¼"	¼"	¼"	Manual Return	
DCC-LB2V1	3500 LPM	½"	½"	½"	Spring Return(NC)	
DCC-LZ2V1	3500 LPM	½"	½"	½"	Spring Return(NO)	
DCC-LC2V1	3500 LPM	½"	½"	½"	Manual Return	

5X2 Hand lever valve manual and spring return

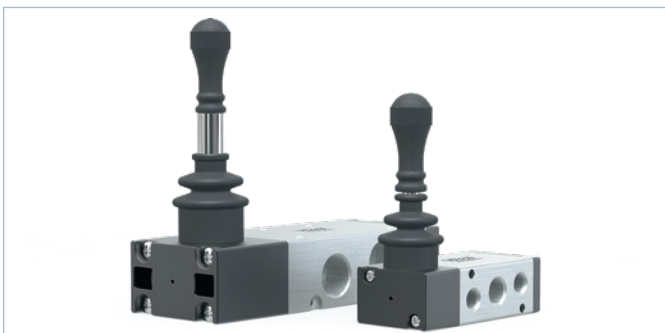

1 - Input, 2/4 - Output, 3/5 - Exhaust

Model No.	Flow (at 6 Bar)	Port Size			Function	Symbol
		In	Out	Exh		
DCC-LD1V1	1200 LPM	¼"	¼"	⅝"	Spring Return	
DCC-LE1V1	1200 LPM	¼"	¼"	⅝"	Manual Return	
DCC-LD2V1	3500 LPM	½"	½"	½"	Spring Return	
DCC-LE2V1	3500 LPM	½"	½"	½"	Manual Return	

5X3 Hand lever valve manual return



1 - Input, 2/4 - Output, 3/5 - Exhaust

Model No.	Flow (at 6 Bar)	Port Size			Function	Symbol
		In	Out	Exh		
DCC-LF1V1	1200 LPM	¼"	¼"	⅜"	Center Blocked	
DCC-LG1V1	1200 LPM	¼"	¼"	⅜"	Center Exhausted	
DCC-LH1V1	1200 LPM	¼"	¼"	⅜"	Center Pressurised	
DCC-LF2V1	3500 LPM	½"	½"	½"	Center Blocked	
DCC-LG2V1	3500 LPM	½"	½"	½"	Center Exhausted	
DCC-LH2V1	3500 LPM	½"	½"	½"	Center Pressurised	

5X3 Hand lever valve with spring center



1 - Input, 2/4 - Output, 3/5 - Exhaust

Model No.	Flow (at 6 Bar)	Port Size			Function	Symbol
		In	Out	Exh		
DCC-LJ1V1	1200 LPM	¼"	¼"	⅜"	Center Blocked	
DCC-LK1V1	1200 LPM	¼"	¼"	⅜"	Center Exhausted	
DCC-LM1V1	1200 LPM	¼"	¼"	⅜"	Center Pressurised	
DCC-LJ2V1	3500 LPM	½"	½"	½"	Center Blocked	
DCC-LK2V1	3500 LPM	½"	½"	½"	Center Exhausted	
DCC-LM2V1	3500 LPM	½"	½"	½"	Center Pressurised	

3X2 External pilot operated valve



1 - Input, 2/4 - Output, 3/5 - Exhaust, 10/12 - External Pilot

Model No.	Flow (at 6 Bar)	Port Size			Function	Symbol
		In	Out	Exh		
DCC-AB1V1	1200 LPM	¼"	¼"	¼"	Spring Return(NC)	
DCC-AZ1V1	1200 LPM	¼"	¼"	¼"	Spring Return(NO)	
DCC-AC1V1	1200 LPM	¼"	¼"	¼"	Double External	
DCC-AB2V1	3500 LPM	½"	½"	½"	Spring Return(NC)	
DCC-AZ2V1	3500 LPM	½"	½"	½"	Spring Return(NO)	
DCC-AC2V1	3500 LPM	½"	½"	½"	Double External	

5X2 External pilot operated valve



1 - Input, 2/4 - Output, 3/5 - Exhaust, 10/12 - External Pilot

Model No.	Flow (at 6 Bar)	Port Size			Function	Symbol
		In	Out	Exh		
DCC-AD1V1	1200 LPM	¼"	¼"	⅙"	Spring Return	
DCC-AE1V1	1200 LPM	¼"	¼"	⅙"	Double External	
DCC-AD2V1	3500 LPM	½"	½"	½"	Spring Return	
DCC-AE2V1	3500 LPM	½"	½"	½"	Double External	

5X3 Double external pilot operated valve with spring center



1 - Input, 2/4 - Output, 3/5 - Exhaust, , 10/12 - External Pilot

Model No.	Flow (at 6 Bar)	Port Size			Function	Symbol
		In	Out	Exh		
DCC-AJ1V1	1200 LPM	¼"	¼"	⅙"	Center Blocked	
DCC-AK1V1	1200 LPM	¼"	¼"	⅙"	Center Exhausted	
DCC-AM1V1	1200 LPM	¼"	¼"	⅙"	Center Pressurised	
DCC-AJ2V1	3500 LPM	½"	½"	½"	Center Blocked	
DCC-AK2V1	3500 LPM	½"	½"	½"	Center Exhausted	
DCC-AM2V1	3500 LPM	½"	½"	½"	Center Pressurised	

3X2 Push pull valve manual and spring return



1 - Input, 2/4 - Output, 3/5 - Exhaust

Model No.	Flow (at 6 Bar)	Port Size			Function	Symbol
		In	Out	Exh		
DCC-PB1V1	1200 LPM	¼"	¼"	¼"	Spring Return(NC)	
DCC-PZ1V1	1200 LPM	¼"	¼"	¼"	Spring Return(NO)	
DCC-PC1V1	1200 LPM	¼"	¼"	¼"	Manual Return	
DCC-PB2V1	3500 LPM	½"	½"	½"	Spring Return(NC)	
DCC-PZ2V1	3500 LPM	½"	½"	½"	Spring Return(NO)	
DCC-PC2V1	3500 LPM	½"	½"	½"	Manual Return	

5X2 Push pull valve manual and spring return



1 - Input, 2/4 - Output, 3/5 - Exhaust

Model No.	Flow (at 6 Bar)	Port Size			Function	Symbol
		In	Out	Exh		
DCC-PD1V1	1200 LPM	¼"	¼"	⅙"	Spring Return	
DCC-PE1V1	1200 LPM	¼"	¼"	⅙"	Manual Return	
DCC-PD2V1	3500 LPM	½"	½"	½"	Spring Return	
DCC-PE2V1	3500 LPM	½"	½"	½"	Manual Return	

DCC-SERIES DC SPOOL WITH CARTRIDGE TYPE VALVE MODEL CHART

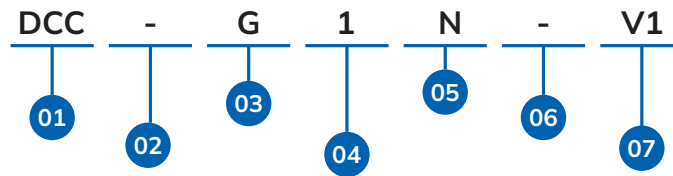

01	SERIES
DCC	DCC

02	PRODUCT TYPE
-	DC Spool With Cartridge Type Valve

03	PORT POSITION & TYPE
A	3X2 NO Single Solenoid
B	3X2 NC Single Solenoid
C	3X2 Double Solenoid
D	5X2 Single Solenoid
E	5X2 Double Solenoid
F	5X3 Center Blocked
G	5X3 Center Exhausted
H	5X3 Center Pressurised
J	3X2 & 5X2 Single Solenoid Convertible
K	3X2 & 5X2 Double Solenoid Convertible

04	PORT SIZE
1	1/4"
2	1/2"

05	PORT CONNECTION
-	BSP
N	NPT
R	Namur BSP
T	Namur NPT

06	CONFIGURATION
-	REGULAR
C1	CONFIG 1
...	...
C9	CONFIG 9
CA	CONFIG 10
CB	CONFIG 11

07	VERSION
-	VERSION 0
V1	VERSION 1
V2	VERSION 2
V3	VERSION 3
...	...
V9	VERSION 9
VA	VERSION 10
VB	VERSION 11

DCC-G1NV1
1/4" 5X3 CENTER EXHAUSTED DC SPOOL WITH CARTRIDGE TYPE VALVE ALUMINIUM-NPT-NITRILE-2 TO 10 Bar-10MM-PUSH & TURN MOR-VERSION 1

Note: The above chart is for identification purposes only, and it may not be possible to make all combinations for the above chart.

DCC - SERIES DC CARTRIDGE TYPE MANUAL VALVE MODEL CHART

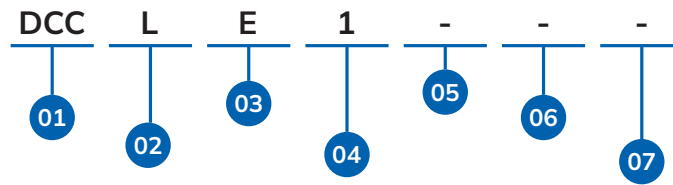

01	SERIES
	DCC

02	PRODUCT TYPE
L	DC Lever Type Valve
P	DC Push Pull Type Valve
A	DC Pilot Air Type Valve

03	PORT POSITION & TYPE
Z	3x2 No With Spring Return
B	3x2 Nc With Spring Return
C	3x2 Double Acting
D	5x2 With Spring Return
E	5x2 Double Acting
F	5x3 Center Blocked With Manual Return
G	5x3 Center Exhausted With Manual Return
H	5x3 Center Pressurised With Manual Return
J	5x3 Center Blocked With Spring Return
K	5x3 Center Exhausted With Spring Return
M	5x3 Center Pressurised With Spring Return

04	PORT SIZE
1	1/4"
2	1/2"

05	PORT SIZE
-	BSP
N	NPT

06	CONFIGURATION
-	REGULAR
C1	CONFIG 1
C2	CONFIG 2
C3	CONFIG 3
⋮	⋮
C9	CONFIG 9
CA	CONFIG 10
CB	CONFIG 11

07	CONFIG
-	VERSION 0
V1	VERSION 1
V2	VERSION 2
V3	VERSION 3
⋮	⋮
V9	VERSION 9
VA	VERSION 10
VB	VERSION 11

DCC-LE1
1/4" 5X2 DOUBLE ACTING DC LEVER TYPE VALVE ALUMINIUM-BSP-NITRILE-0 TO 10 Bar

Note : The above chart is for identification purposes only, and it may not be possible to make all combinations for the above chart.

Model Information

Type:	Solenoid Operated, Lever Operated, Pilot Air Operated, Push Pull (3X2-NC / NO, 5X2, 5X3)
Design:	Spool Type
Media:	Compressed Air (Filtered & Lubricated)
Working Pressure Range:	2 - 10 Bar for Solenoid Valve 0 - 10 Bar for Manual Valve & Air Pilot Valve
Ambient / Media Temperature:	5°C - 60°C
Materials of Construction:	Aluminium, Nitrile, Brass, Polymer

Coil Information

Coil Width :	26 mm
Coil Bore :	10 mm
Voltage (V) ± 10% :	AC (50Hz, 60Hz) - 24V, 110V, 230V DC 12V, 24V, 36V, 48V, 110V
Power Consumption :	AC-6W, DC-6W
Duty Cycle :	Continuous
Class of Insulation :	Class H
Type of Coil Protection :	IP65
Coil Housing :	Epoxy Square Coil

FEATURES

- Cartridge Type Design For Long Life
- Compact Design
- Standard NAMUR Mounting
- 1 Million Cycle Tested
- Low Power Consumption
- Manual Override
- Lubrication Not Essential
- Wide Range Of Coil Voltage

3X2, 5X2 Single solenoid valve with spring return



1 - Input, 2/4 - Output, 3/5 - Exhaust

Model No.	Flow (at 7 Bar)	Port Size			Function	Symbol
		In	Out	Exh		
DCS-B1V1	1350 LPM	¼"	¼"	¼"	Spring Return (NC)	
DCS-A1V1	1350 LPM	¼"	¼"	¼"	Spring Return (NO)	
DCS-D1V1	1350 LPM	¼"	¼"	⅝"	Spring Return	
DCS-B2V1	3500 LPM	½"	½"	½"	Spring Return (NC)	
DCS-A2V1	3500 LPM	½"	½"	½"	Spring Return (NO)	
DCS-D2V1	3500 LPM	½"	½"	½"	Spring Return	

3X2, 5X2 Double solenoid valve



1 - Input, 2/4 - Output, 3/5 - Exhaust

Model No.	Flow (at 7 Bar)	Port Size			Function	Symbol
		In	Out	Exh		
DCS-C1V1	1350 LPM	¼"	¼"	¼"	Double Solenoid	
DCS-E1V1	1350 LPM	¼"	¼"	⅝"	Double Solenoid	
DCS-C2V1	3500 LPM	½"	½"	½"	Double Solenoid	
DCS-E2V1	3500 LPM	½"	½"	½"	Double Solenoid	

3X2, 5X2 Single solenoid namur valve with spring return



1 - Input, 2/4 - Output, 3/5 - Exhaust

Model No.	Flow (at 7 Bar)	Port Size			Function	Symbol
		In	Out	Exh		
DCS-J1RV1	1350 LPM	¼"	Namur	¼"	3X2 Spring Return	
	1350 LPM	¼"	Namur	¼"	5X2 Spring Return	

3X2, 5X2 Double solenoid namur valve

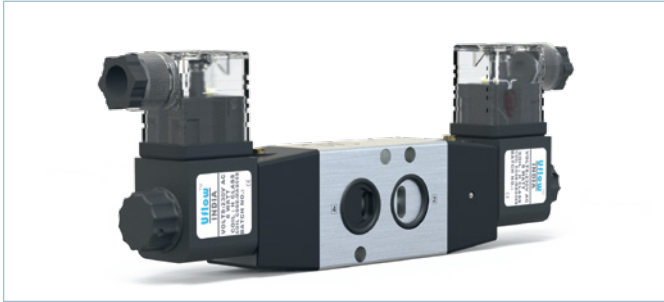

1 - Input, 2/4 - Output, 3/5 - Exhaust

Model No.	Flow (at 7 Bar)	Port Size			Function	Symbol
		In	Out	Exh		
DCS-K1RV1	1350 LPM	¼"	Namur	¼"	3X2 Double Solenoid	
	1350 LPM	¼"	Namur	¼"	5X2 Double Solenoid	

5X3 Double solenoid valve with spring center



1 - Input, 2/4 - Output, 3/5 - Exhaust

Model No.	Flow (at 7 Bar)	Port Size			Function	Symbol
		In	Out	Exh		
DCS-F1V1	1350 LPM	¼"	¼"	⅝"	Center Blocked	
DCS-G1V1	1350 LPM	¼"	¼"	⅝"	Center Exhausted	
DCS-H1V1	1350 LPM	¼"	¼"	⅝"	Center Pressurised	
DCS-F2V1	3500 LPM	½"	½"	½"	Center Blocked	
DCS-G2V1	3500 LPM	½"	½"	½"	Center Exhausted	
DCS-H2V1	3500 LPM	½"	½"	½"	Center Pressurised	

3X2 Hand lever valve manual and spring return



1 - Input, 2/4 - Output, 3/5 - Exhaust

Model No.	Flow (at 7 Bar)	Port Size			Function	Symbol
		In	Out	Exh		
DCS-LB1V1	1350 LPM	¼"	¼"	¼"	Spring Return(NC)	
DCS-LZ1V1	1350 LPM	¼"	¼"	¼"	Spring Return(NO)	
DCS-LC1V1	1350 LPM	¼"	¼"	¼"	Manual Return	
DCS-LB2V1	3500 LPM	½"	½"	½"	Spring Return(NC)	
DCS-LZ2V1	3500 LPM	½"	½"	½"	Spring Return(NO)	
DCS-LC2V1	3500 LPM	½"	½"	½"	Manual Return	

5X2 Hand lever valve manual and spring return

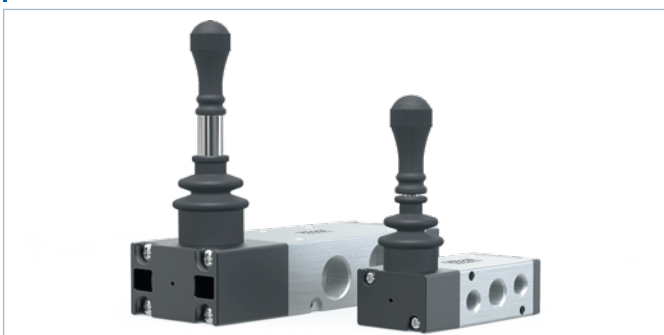

1 - Input, 2/4 - Output, 3/5 - Exhaust

Model No.	Flow (at 7 Bar)	Port Size			Function	Symbol
		In	Out	Exh		
DCS-LD1V1	1350 LPM	¼"	¼"	⅝"	Spring Return	
DCS-LE1V1	1350 LPM	¼"	¼"	⅝"	Manual Return	
DCS-LD2V1	3500 LPM	½"	½"	½"	Spring Return	
DCS-LE2V1	3500 LPM	½"	½"	½"	Manual Return	

5X3 Hand lever valve manual return



1 - Input, 2/4 - Output, 3/5 - Exhaust

Model No.	Flow (at 7 Bar)	Port Size			Function	Symbol
		In	Out	Exh		
DCS-LF1V1	1350 LPM	¼"	¼"	⅝"	Center Blocked	
DCS-LG1V1	1350 LPM	¼"	¼"	⅝"	Center Exhausted	
DCS-LH1V1	1350 LPM	¼"	¼"	⅝"	Center Pressurised	
DCS-LF2V1	3500 LPM	½"	½"	½"	Center Blocked	
DCS-LG2V1	3500 LPM	½"	½"	½"	Center Exhausted	
DCS-LH2V1	3500 LPM	½"	½"	½"	Center Pressurised	

5X3 Hand lever valve with spring center



1 - Input, 2/4 - Output, 3/5 - Exhaust

Model No.	Flow (at 7 Bar)	Port Size			Function	Symbol
		In	Out	Exh		
DCS-LJ1V1	1350 LPM	¼"	¼"	⅝"	Center Blocked	
DCS-LK1V1	1350 LPM	¼"	¼"	⅝"	Center Exhausted	
DCS-LM1V1	1350 LPM	¼"	¼"	⅝"	Center Pressurised	
DCS-LJ2V1	3500 LPM	½"	½"	½"	Center Blocked	
DCS-LK2V1	3500 LPM	½"	½"	½"	Center Exhausted	
DCS-LM2V1	3500 LPM	½"	½"	½"	Center Pressurised	

3X2 External pilot operated valve



1 - Input, 2/4 - Output, 3/5 - Exhaust, 10/12 - External Pilot

Model No.	Flow (at 7 Bar)	Port Size			Function	Symbol
		In	Out	Exh		
DCS-AB1V1	1350 LPM	¼"	¼"	¼"	Spring Return(NC)	
DCS-AZ1V1	1350 LPM	¼"	¼"	¼"	Spring Return(NO)	
DCS-AC1V1	1350 LPM	¼"	¼"	¼"	Double External	
DCS-AB2V1	3500 LPM	½"	½"	½"	Spring Return(NC)	
DCS-AZ2V1	3500 LPM	½"	½"	½"	Spring Return(NO)	
DCS-AC2V1	3500 LPM	½"	½"	½"	Double External	

5X2 External pilot operated valve



1 - Input, 2/4 - Output, 3/5 - Exhaust, 10/12 - External Pilot

Model No.	Flow (at 7 Bar)	Port Size			Function	Symbol
		In	Out	Exh		
DCS-AD1V1	1350 LPM	¼"	¼"	⅙"	Spring Return	
DCS-AE1V1	1350 LPM	¼"	¼"	⅙"	Double External	
DCS-AD2V1	3500 LPM	½"	½"	½"	Spring Return	
DCS-AE2V1	3500 LPM	½"	½"	½"	Double External	

5X3 Double external pilot operated valve with spring center



1 - Input, 2/4 - Output, 3/5 - Exhaust, , 10/12 - External Pilot

Model No.	Flow (at 7 Bar)	Port Size			Function	Symbol
		In	Out	Exh		
DCS-AJ1V1	1350 LPM	¼"	¼"	⅙"	Center Blocked	
DCS-AK1V1	1350 LPM	¼"	¼"	⅙"	Center Exhausted	
DCS-AM1V1	1350 LPM	¼"	¼"	⅙"	Center Pressurised	
DCS-AJ2V1	3500 LPM	½"	½"	½"	Center Blocked	
DCS-AK2V1	3500 LPM	½"	½"	½"	Center Exhausted	
DCS-AM2V1	3500 LPM	½"	½"	½"	Center Pressurised	

3X2 Push pull valve manual and spring return



1 - Input, 2/4 - Output, 3/5 - Exhaust

Model No.	Flow (at 7 Bar)	Port Size			Function	Symbol
		In	Out	Exh		
DCS-PB1V1	1350 LPM	¼"	¼"	¼"	Spring Return(NC)	
DCS-PZ1V1	1350 LPM	¼"	¼"	¼"	Spring Return(NO)	
DCS-PC1V1	1350 LPM	¼"	¼"	¼"	Manual Return	
DCS-PB2V1	3500 LPM	½"	½"	½"	Spring Return(NC)	
DCS-PZ2V1	3500 LPM	½"	½"	½"	Spring Return(NO)	
DCS-PC2V1	3500 LPM	½"	½"	½"	Manual Return	

5X2 Push pull valve manual and spring return



1 - Input, 2/4 - Output, 3/5 - Exhaust

Model No.	Flow (at 7 Bar)	Port Size			Function	Symbol
		In	Out	Exh		
DCS-PD1V1	1350 LPM	¼"	¼"	⅙"	Spring Return	
DCS-PE1V1	1350 LPM	¼"	¼"	⅙"	Manual Return	
DCS-PD2V1	3500 LPM	½"	½"	½"	Spring Return	
DCS-PE2V1	3500 LPM	½"	½"	½"	Manual Return	

DCS - SERIES DC SPOOL TYPE VALVE MODEL CHART

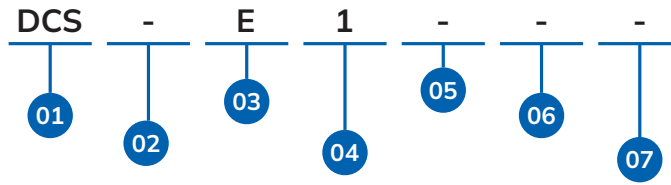

01	SERIES
DCS	

02	PRODUCT TYPE
-	DC Spool Type Valve

03	PORT POSITION & TYPE
A	3x2 NO Single Solenoid
B	3x2 NC Single Solenoid
C	3x2 Double Solenoid
D	5x2 Single Solenoid
E	5x2 Double Solenoid
F	5x3 Center Blocked
G	5x3 Center Exhausted
H	5x3 Center Pressurised
J	3x2 & 5x2 Single Solenoid Convertible
K	3x2 & 5x2 Double Solenoid Convertible

04	PORT SIZE
1	1/4"
2	1/2"

05	PORT SIZE
-	BSP
N	NPT
R	NAMUR BSP
T	NAMUR NPT

06	CONFIGURATION
-	REGULAR
C1	CONFIG 1
C2	CONFIG 2
C3	CONFIG 3
...	...
C9	CONFIG 9
CA	CONFIG 10
CB	CONFIG 11

07	VERSION
-	VERSION 0
V1	VERSION 1
V2	VERSION 2
V3	VERSION 3
...	...
V9	VERSION 9
VA	VERSION 10
VB	VERSION 11

DCS-E1
1/4" 5X2 DOUBLE SOLENOID DC SPOOL TYPE VALVE ALUMINIUM-
BSP-HNBR-2 TO 10 BAR-10MM-PUSH & TURN MOR

Note : The above chart is for identification purposes only, and it may not be possible to make all combinations for the above chart.

DCS - SERIES DC SPOOL TYPE MANUAL VALVE MODEL CHART

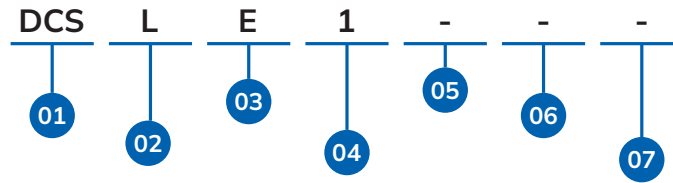

01	SERIES
	DCS

02	PRODUCT TYPE
L	DC Lever Type Valve
P	DC Push Pull Type Valve
A	DC Pilot Air Type Valve

03	PORT POSITION & TYPE
Z	3x2 No With Spring Return
B	3x2 Nc With Spring Return
C	3x2 Double Acting
D	5x2 With Spring Return
E	5x2 Double Acting
F	5x3 Center Blocked With Manual Return
G	5x3 Center Exhausted With Manual Return
H	5x3 Center Pressurised With Manual Return
J	5x3 Center Blocked With Spring Return
K	5x3 Center Exhausted With Spring Return
M	5x3 Center Pressurised With Spring Return

04	PORT SIZE
1	1/4"
2	1/2"

05	PORT SIZE
-	BSP
N	NPT

06	CONFIGURATION
-	REGULAR
C1	CONFIG 1
C2	CONFIG 2
C3	CONFIG 3
...	...
C9	CONFIG 9
CA	CONFIG 10
CB	CONFIG 11

07	CONFIG
-	VERSION 0
V1	VERSION 1
V2	VERSION 2
V3	VERSION 3
...	...
V9	VERSION 9
VA	VERSION 10
VB	VERSION 11

DCS-LE1
1/4" 5X2 DOUBLE ACTING DC LEVER TYPE VALVE ALUMINIUM-BSP-NITRILE-0 TO 10 Bar

Note : The above chart is for identification purposes only, and it may not be possible to make all combinations for the above chart.

Technical Data for 3X2 Manifold

Model No.	Diagram No.	No. of Valve	A
NT202	20.1	02	102
NT203	20.1	03	138
NT204	20.1	04	174
NT205	20.1	05	210
NT206	20.1	06	246
NT207	20.1	07	282
NT208	20.1	08	318
NT209	20.1	09	354
NT210	20.1	10	390

Technical Data for 5X2 Manifold

Model No.	Diagram No.	No. of Valve	A
NF202	20.2	02	102
NF203	20.2	03	138
NF204	20.2	04	174
NF205	20.2	05	210
NF206	20.2	06	246
NF207	20.2	07	282
NF208	20.2	08	318
NF209	20.2	09	354
NF210	20.2	10	390

FEATURES

- Ease of maintenance.
- Inlet & Exhaust on the manifold.
- Blanking plate can be installed or removed as per need according to future requirements, in case customer wish to add on extra valve.

DIAGRAM NO. 20.1 - DIMENSIONS (MM)

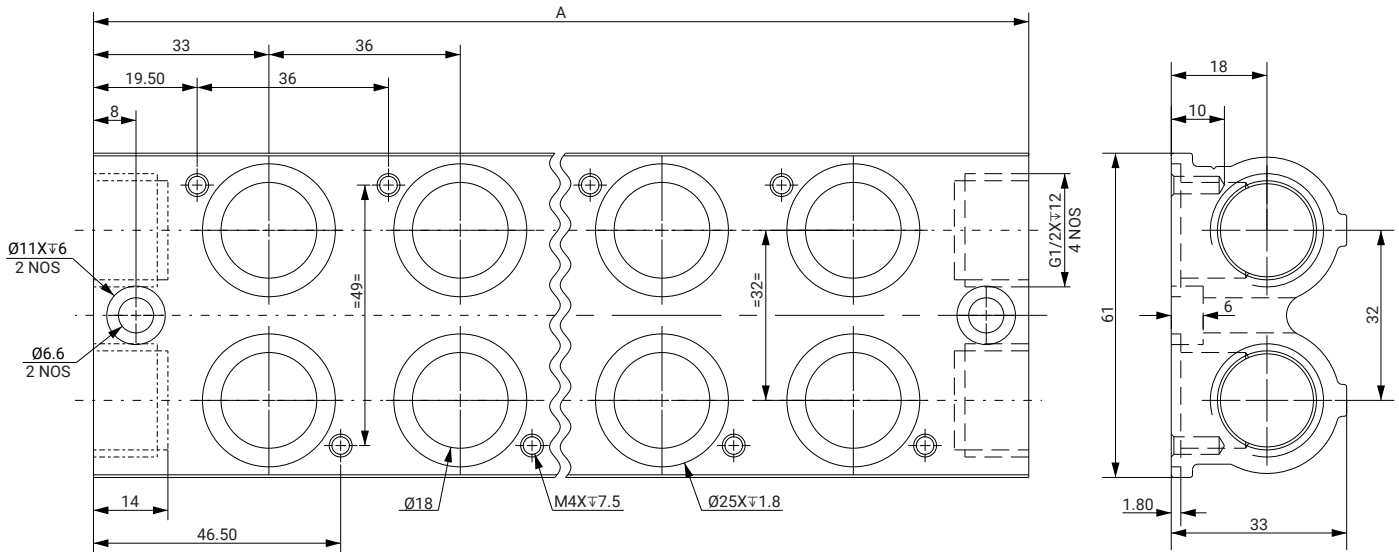
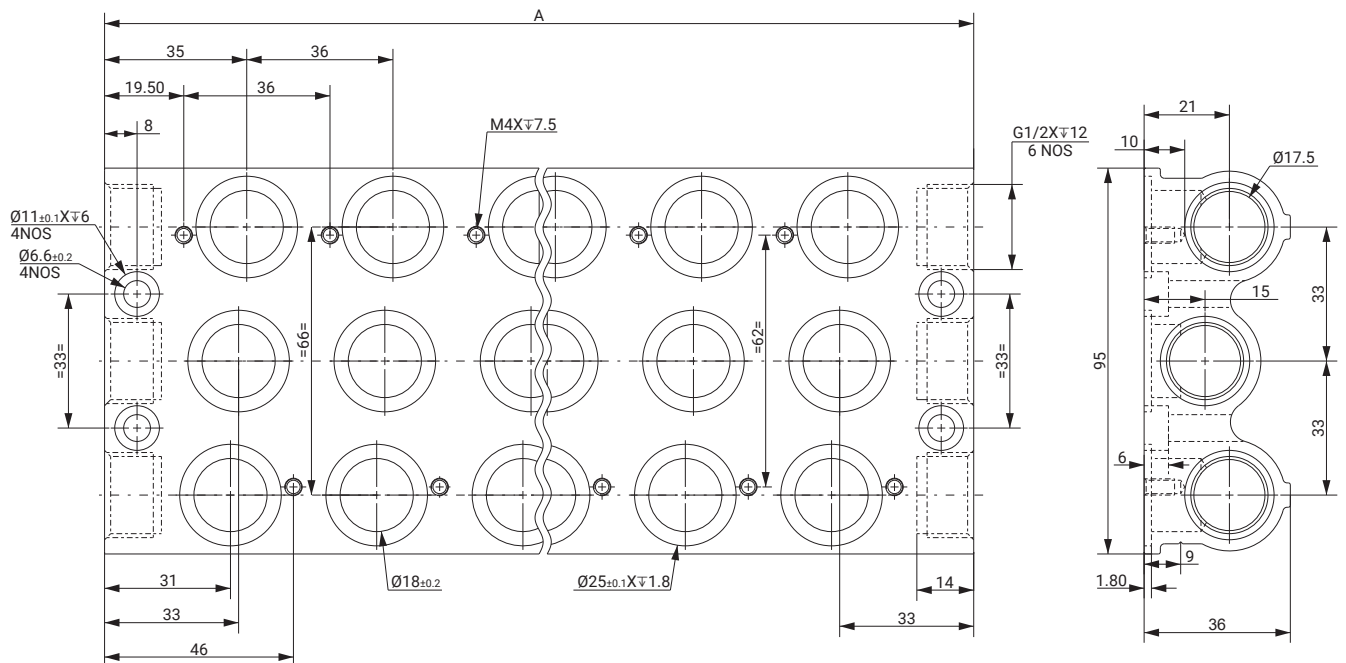
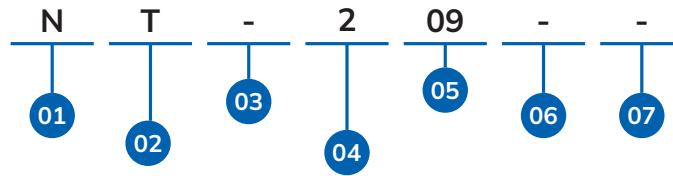

DIAGRAM NO. 20.2 - DIMENSIONS (MM)



MANIFOLD MODEL IDENTIFICATION CHART



01	SERIES
N	MANIFOLD

02	PRODUCT TYPE
T	3X2 DC VALVE
F	5X2 DC VALVE

03	BODY MATERIAL
-	Aluminium

04	PORT SIZE
1	1/4"
2	1/2"

05	NO OF VALVE
01	1
02	2
03	3
04	4
05	5
06	6
07	7
08	8
09	9
10	10

06	CONFIGURATION
-	REGULAR
C1	CONFIG 1
C2	CONFIG 2
C3	CONFIG 3
⋮	⋮
C9	CONFIG 9
CA	CONFIG 10
CB	CONFIG 12

07	VERSION
-	VERSION 0
V1	VERSION 1
V2	VERSION 2
V3	VERSION 3
⋮	⋮
V9	VERSION 9
VA	VERSION 10
VB	VERSION 11

NT209
1/2" MANIFOLD ALUMINIUM 9 NOS OF 3X2 DIRECTIONAL CONTROL VALVE

Note: The above chart is for identification purposes only, and it may not be possible to make all combinations for the above chart.



PNEUMATIC AIR CYLINDER SERIES

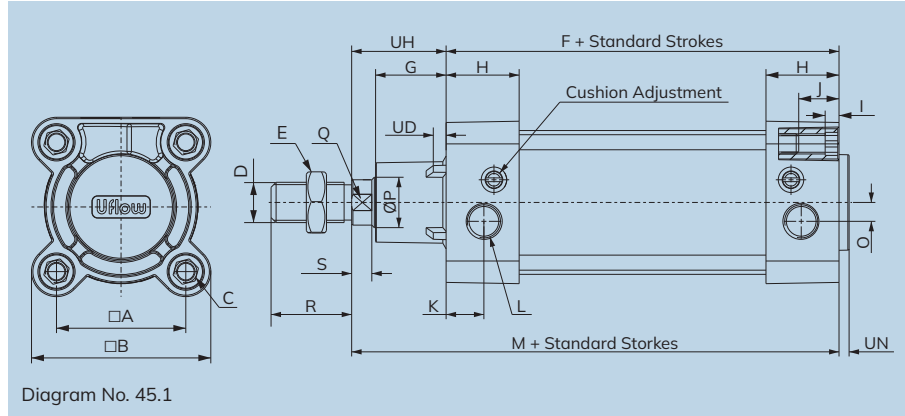

Specifications

Cylinder bore Ø (mm) :	32	40	50	63	80	100	125	160	200	250
Cushion stroke (mm) :	21	23	23	23	28	28	40	40	40	50
Standard strokes (mm):	25, 50, 80, 100, 125, 160, 200, 250, 300, 320, 400, 500									
Media :	Compressed air - filtered - lubricated									
Working pressure :	0.5 - 10 bar									
Medium temperature :	Regular +5°C to +60°C		High temperature applications +5°C to +150°C Max							
Materials of Construction :	Aluminium, Brass, Steel, Acetal, Polyurethane, Nitrile (Regular), FKM (High temperature)									
Mountings :	Foot Mounting, Front Flange, Rear Flange, Male Clevis, Female Clevis, Female Clevis (king Pin), Center Trunnion, Front Trunnion , Rear Trunnion									
Accessories :	Clevis Foot Bracket, Wall Mounting Bracket, Trunnion Bracket, Rod End Fork, Rod End Aligner, Rod End Spherical Eye									

Features

- Adjustable cushioning at both ends with elastomer pads.
- Wide varieties of mountings.
- Optional - High temperature (Viton seals) 150°C max.
- Optional - Non corrosive stainless steel piston rod and piston rod lock nut (SS304)

Technical Data

All Dimension in mm

Cylinder bore Ø	A	B	C	D	E	F + TOL	G	H	I	J	K	L	M + TOL	UN	O	P	Q	R	S	ØT	UD	UH + TOL	Stroke tol
32	32.5	45	M6	M10X1.25	17	94 ±0.6	18.5	25.5	5	16	13	G ¹ / ₈	120 ±1	4	5	12	10	22	6	30	6	26	+2
40	38	51	M6	M12X1.25	19	105 ±0.6	20.5	29	5	16	14.5	G ¹ / ₄	135 ±1	4	5	16	13	24	6.5	35	6.5	30	+1.3
50	46.5	64	M8	M16X1.5	24	106 ±0.7	28	29	6	16	15	G ¹ / ₄	143 ±1.1	4	7.5	20	16	32	8	40	6.5	37	+0
63	56.5	74	M8	M16X1.5	24	121 ±0.8	27.5	35	6	16	17	G ³ / ₈	158 ±1.1	4	10	20	16	32	8	45	6.5	37	+2.5
80	72	94	M10	M20X1.5	30	128 ±0.8	34	35	6	16	18	G ³ / ₈	174 ±1.1	4	14	25	21	40	10	45	6.5	46	+1.5
100	89	111	M10	M20X1.5	30	138 ±1.0	35	38.5	6	16	18	G ¹ / ₂	189 ±1.2	4	10	25	21	40	10	55	6.5	51	+0
125	110	136	M12	M27X2	41	160 ±1.0	46.5	44	-	20	20	G ¹ / ₂	225 ±1.2	6	12	32	27	54	10	60	10	65	+4
160	140	183	M16	M36X2	55	180 ±1.1	60	50.7	-	24	31	G ³ / ₄	260 ±1.5	6	12	40	36	72	8	65	8	60	+2.2
200	175	222	M16	M36X2	55	180 ±1.6	70	46.7	-	24	30	G ³ / ₄	275 ±1.5	6	12	40	36	72	8	75	8	95	+0
250	220	272	M20	M42X2	65	200 ±1.6	75	51.2	-	25	32	G1	305 ±2	10	25	50	46	84	12	90	12	105	+5

Output Force

(Force in N : 1N = 0.1 kgf)

Cylinder bore Ø (mm)	Rod Ø (mm)		Working pressure in bar								
			2	3	4	5	6	7	8	9	10
32	12	Extend	145	217	289	362	434	507	579	651	724
		Retract	124	187	249	311	373	435	498	559	621
40	16	Extend	226	339	452	565	678	792	905	1018	1130
		Retract	190	285	380	475	570	665	760	855	950
50	20	Extend	353	530	706	884	1060	1237	1414	1590	1767
		Retract	297	445	594	742	891	1039	1187	1336	1484
63	20	Extend	561	842	1122	1403	1683	1964	2244	2525	2805
		Retract	505	757	1009	1261	1514	1766	2018	2270	2523
80	25	Extend	905	1357	1809	2262	2714	3167	3619	4072	4524
		Retract	816	1225	1633	2041	2449	2857	3266	3674	4082
100	25	Extend	1414	2120	2828	3534	4241	4948	5655	6362	7069
		Retract	1325	1988	2650	3313	3976	4640	5300	5965	6625
125	32	Extend	2209	3313	4417	5522	6626	7731	8835	9940	11044
		Retract	2064	3096	4128	5160	6192	7224	8256	9288	10320
160	40	Extend	3619	5428	7238	9047	10857	12666	14476	16286	18095
		Retract	3392	5089	6785	8482	10178	11875	13571	15268	16964
200	40	Extend	5654	8482	11309	14137	16964	19792	22619	25446	28274
		Retract	5428	8143	10857	13571	16286	19000	21714	24429	27143
250	50	Extend	8836	13253	17671	22089	26507	30925	35343	39760	44178
		Retract	8482	12723	16964	21205	25446	29688	33929	38170	42411

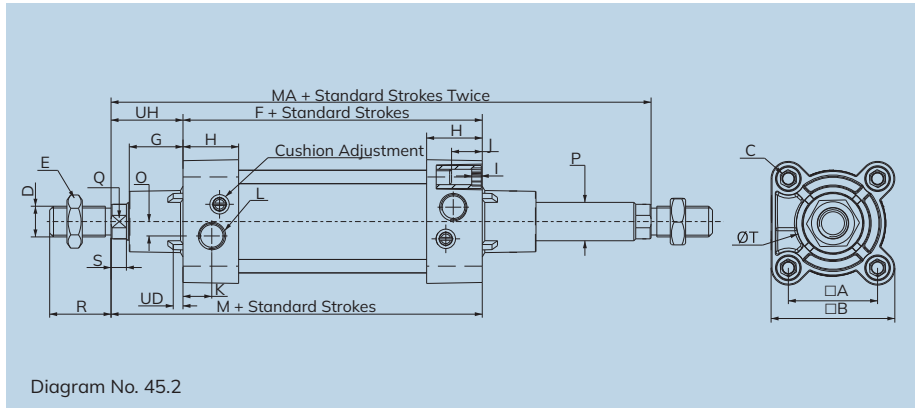

Specifications

Cylinder Bore Ø (mm) :	32	40	50	63	80	100	125	160	200
Cushion Stroke (mm) :	21	23	23	23	28	28	40	40	40
Standard Strokes (mm):	25, 50, 80, 100, 125, 160, 200, 250, 300, 320, 400, 500								
Media :	Compressed air - filtered - lubricated								
Working Pressure :	0.5 - 10 bar								
Medium Temperature :	Regular +5°C to +60°C		High Temperature Applications +5°C to +150°C Max						
Materials of Construction :	Aluminium, Brass, Steel, Acetal, Polyurethane, Nitrile (Regular), FKM (High temperature)								
Mountings	Foot Mounting, Flange, Female Clevis, Front Trunnion, Center Trunnion								
Accessories	Clevis Foot Bracket, Wall Mounting Bracket, Trunnion Bracket, Rod End Fork, Rod End Aligner, Rod End Spherical Eye								

Features

- Adjustable cushioning at both ends with pads.
- Wide varieties of mountings.
- Optional - High temperature (Viton seals) 150°C max.
- Optional - Non corrosive stainless steel piston rod and piston rod lock nut (SS304)

Technical Data

All Dimension in mm

Cylinder bore Ø	A	B	C	D	E	F +TOL	G	H	I	J	K	L	M +TOL	MA +TOL	O	P	Q	R	S	ØT	UD	UH +TOL	Stroke tol				
32	32.5	45	M6	M10X1.25	17	94	±0.6	18.5	25.5	5	16	13	G½	120	±1	147	5	12	10	22	6	30	6	26	+2		
40	38	51	M6	M12X1.25	19	105	±0.6	20.5	29	5	16	14.5	G¼	135	±1.5	166	5	16	13	24	6.5	35	6.5	30	±1.3	0	
50	46.5	64	M8	M16X1.5	24	106	±0.7	28	29	6	16	15	G¼	143	±1.5	181	7.5	20	16	32	8	40	6.5	37	+2.5		
63	56.5	74	M8	M16X1.5	24	121	±0.8	27.5	35	6	16	17	G¾	158	±1.1	196	10	20	16	32	8	45	6.5	37	0		
80	72	94	M10	M20X1.5	30	128	±0.8	34	35	6	16	18	G¾	174	±1.1	221	14	25	21	40	10	45	6.5	46	±1.5	+2.5	
100	89	111	M10	M20X1.5	30	138	±1	35	38.5	6	16	18	G½	189	±1.2	241	10	25	21	40	10	55	6.5	51	0		
125	110	136	M12	M27X2	41	160	±1	48.5	44	6	20	20	G½	225	±1.2	292	12	32	27	54	13	60	10	66	+4		
160	140	183	M18	M36X2	55	180	±1.1	60	51	-	24	26	G¾	260	±1.5	341	±2	12	40	36	72	16	65	8	80	±2.2	0
200	175	222	M16	M36X2	55	180	±1.6	70	46	-	24	25	G¾	275	±1.5	372	25	40	36	72	16	75	8	96	0		

Output Force

(Force in N : 1N = 0.1 kgf)

Cylinder bore Ø (mm)	Rod Ø (mm)	Working pressure in bar									
		2	3	4	5	6	7	8	9	10	
32	12	124	187	249	311	373	435	498	559	621	
40	16	190	285	380	475	570	665	760	855	950	
50	20	297	445	594	742	891	1039	1187	1336	1484	
63	20	505	757	1009	1261	1514	1766	2018	2270	2523	
80	25	816	1225	1633	2041	2449	2857	3266	3674	4082	
100	25	1325	1988	2650	3313	3976	4640	5300	5965	6625	
125	32	2064	3096	4128	5160	6192	7224	8256	9288	10320	
160	40	3392	5089	6785	8482	10178	11875	13571	15268	16964	
200	40	5428	8143	10857	13571	16286	19000	21714	24429	27143	

CS4 - SERIES TIE ROD PNEUMATIC CYLINDER ISO 1552 MODEL CHART

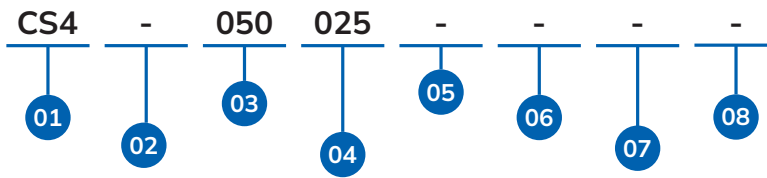

01	SERIES
CS4	

02	PRODUCT TYPE
-	Tie Rod Cylinder
M	Magnetic Tie Rod Cylinder
D	Tie Rod Double end Cylinder
R	Magnetic Tie Rod Double end Cylinder

03	BORE Ø (mm)
032	32
040	40
050	50
063	63
080	80
100	100
125	125
160	160
200	200
250	250

04	STROKE (mm)
010	10
025	25
040	40
050	50
⋮	⋮
1600	1600

05	SEAL MATERIAL
-	NBR
V	VITON

06	OPTIONAL
-	SS 420
S	PISTON ROD SS304

07	CONFIGURATION
-	REGULAR
C1	CONFIG 1
⋮	⋮
C9	CONFIG 9
CA	CONFIG 10
CB	CONFIG 11

08	VERSION
-	VERSION 0
V1	VERSION 1
V2	VERSION 2
V3	VERSION 3
⋮	⋮
V9	VERSION 9
VA	VERSION 10
VB	VERSION 11

CS4-050025
TIE ROD CYLINDER OD 50-STROKE 25-NBR-SS 420

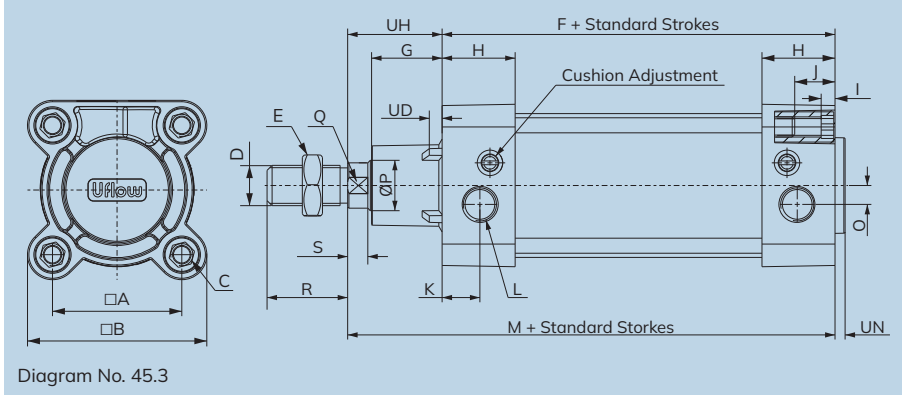
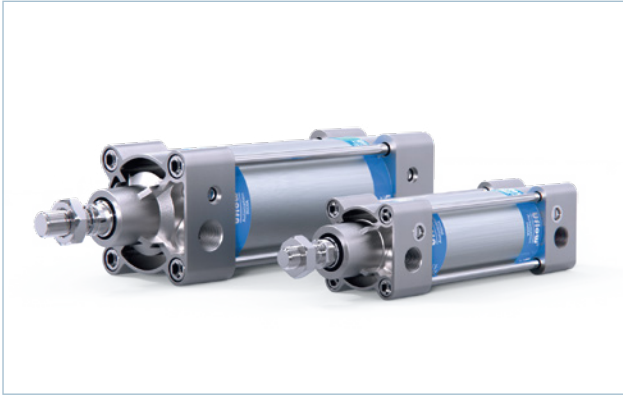

Specifications

Cylinder bore Ø (mm) :	32	40	50	63	80	100
Cushion stroke (mm) :	21	23	23	23	28	28
Standard strokes (mm):	25, 50, 80, 100, 125, 160, 200, 250, 300, 320, 400, 500					
Media :	Compressed air - filtered - lubricated					
Working pressure :	0.5 - 10 bar					
Medium temperature :	Regular +5°C to +60°C		High temperature applications +5°C to +150°C Max			
Materials of Construction :	Aluminium, Brass, Steel, Acetal, Polyurethane, Nitrile (Regular), FKM (High temperature)					
Mountings	Foot Mounting, Front Flange, Rear Flange, Male Clevis, Female Clevis, Female Clevis (king Pin), Center Trunnion, Front Trunnion, Rear Trunnion					
Accessories	Clevis Foot Bracket, Wall Mounting Bracket, Trunnion Bracket, Rod End Fork, Rod End Aligner, Rod End Spherical Eye					

Features

- Adjustable cushioning at both ends with elastomer pads.
- Wide varieties of mountings.
- Optional - High temperature (Viton seals) 150°C max.
- Optional - Non corrosive stainless steel piston rod and piston rod lock nut (SS304)

Technical Data

All Dimension in mm

Cylinder bore Ø	A	B	C	D	E	F + TOL	G	H	I	J	K	L	M + TOL	UN	O	P	Q	R	S	ØT	UD	UH + TOL	Stroke tol		
32	32	44	M6	M10X1.25	17	94	±0.6	20.5	25	5	16	8.5	G ³ / ₄	120	4	0	12	10	22	6	30	6	26		
40	40	55	M6	M12X1.25	19	105	±0.6	24.5	28	5	16	12	G ³ / ₄	135	±1	4	3	16	13	24	6.5	35	6.5	30	+1.3
50	48	63	M8	M16X1.5	24	106	±0.7	30	30	6	16	12	G ³ / ₄	143		4	5	20	16	32	8	40	6.5	37	
63	60	83	M8	M16X1.5	24	121	±0.8	30.5	33	6	16	16.5	G ³ / ₄	158	±1.1	4	10	20	16	32	8	45	6.5	37	
80	72	98	M10	M20X1.5	30	128	±0.8	38.5	33	6	16	16	G ³ / ₄	174		4	15	25	21	40	10	45	6.5	46	+1.5
100	89	115	M10	M20X1.5	30	138	±0.8	44	37	6	16	18	G ¹ / ₂	189		4	15	25	21	40	10	55	6.5	51	+0

Output Force

(Force in N : 1N = 0.1 kgf)

Cylinder bore Ø (mm)	Rod Ø (mm)		Working pressure in bar									
			2	3	4	5	6	7	8	9	10	
32	12	Extend	145	217	289	362	434	507	579	651	724	
		Retract	124	187	249	311	373	435	498	559	621	
40	16	Extend	226	339	452	565	678	792	905	1018	1130	
		Retract	190	285	380	475	570	665	760	855	950	
50	20	Extend	353	530	706	884	1060	1237	1414	1590	1767	
		Retract	297	445	594	742	891	1039	1187	1336	1484	
63	20	Extend	561	842	1122	1403	1683	1964	2244	2525	2805	
		Retract	505	757	1009	1261	1514	1766	2018	2270	2523	
80	25	Extend	905	1357	1809	2262	2714	3167	3619	4072	4524	
		Retract	816	1225	1633	2041	2449	2857	3266	3674	4082	
100	25	Extend	1414	2120	2828	3534	4241	4948	5655	6362	7069	
		Retract	1325	1988	2650	3313	3976	4640	5300	5965	6625	

Pneumatic Cylinder Double End Double Acting - CN4 Series

(As per ISO 6431 / CETOP RP43P, RP53P standards)

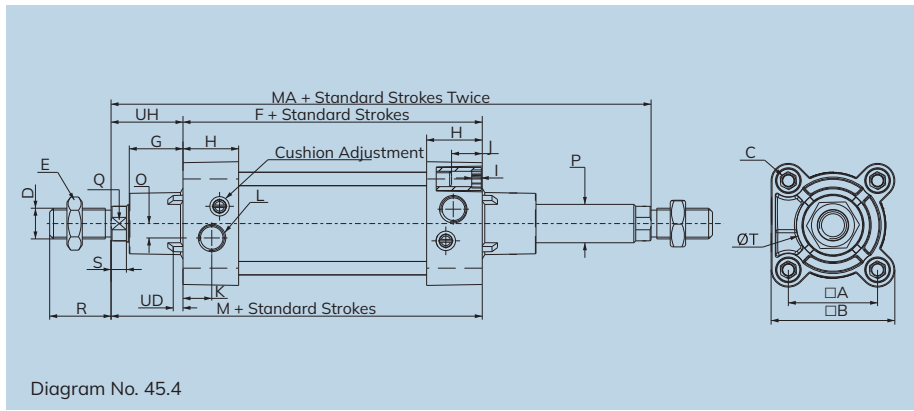

Specifications

Cylinder Bore Ø (mm) :	32	40	50	63	80	100	125	160	200
Cushion Stroke (mm) :	21	23	23	23	28	28	40	40	40
Standard Strokes (mm):	25, 50, 80, 100, 125, 160, 200, 250, 300, 320, 400, 500								
Media :	Compressed air - filtered - lubricated								
Working Pressure :	0.5 - 10 bar								
Medium Temperature :	Regular +5°C to +60°C		High Temperature Applications +5°C to +150°C Max						
Materials of Construction :	Aluminium, Brass, Steel, Acetal, Polyurethane, Nitrile (Regular), FKM (High temperature)								
Mountings	Foot Mounting, Flange, Female Clevis, Front Trunnion, Center Trunnion								
Accessories	Clevis Foot Bracket, Wall Mounting Bracket, Trunnion Bracket, Rod End Fork, Rod End Aligner, Rod End Spherical Eye								

Features

- Adjustable cushioning at both ends with pads.
- Wide varieties of mountings.
- Optional - High temperature (Viton seals) 150°C max.
- Optional - Non corrosive stainless steel piston rod and piston rod lock nut (SS304)

Technical Data

All Dimension in mm

Cylinder bore Ø	A	B	C	D	E	F + TOL	G	H	I	J	K	L	M + TOL	MA + TOL	O	P	Q	R	S	ØT	UD	UH + TOL	Stroke tol		
32	32.5	45	M6	M10X1.25	17	94		18.5	25.5	5	16	13	G $\frac{1}{4}$	120		5	12	10	22	6	30	6	26		
40	38	51	M6	M12X1.25	19	105	±0.6	20.5	29	5	16	14.5	G $\frac{1}{4}$	135		5	16	13	24	6.5	35	6.5	30	±1.3	+2 0
50	46.5	64	M8	M16X1.5	24	106	±0.7	28	29	6	16	15	G $\frac{1}{4}$	143		7.5	20	16	32	8	40	6.5	37		
63	56.5	74	M8	M16X1.5	24	121		27.5	35	6	16	17	G $\frac{3}{8}$	158		10	20	16	32	8	45	6.5	37		
80	72	94	M10	M20X1.5	30	128	±0.8	34	35	6	16	18	G $\frac{3}{8}$	174		14	25	21	40	10	45	6.5	46	±1.5	+2.5 0
100	89	111	M10	M20X1.5	30	138		35	38.5	6	16	18	G $\frac{1}{2}$	189		10	25	21	40	10	55	6.5	51		

Output Force

(Force in N : 1N = 0.1 kgf)

Cylinder bore Ø (mm)	Rod Ø (mm)	Working pressure in bar								
		2	3	4	5	6	7	8	9	10
32	12	124	187	249	311	373	435	498	559	621
40	16	190	285	380	475	570	665	760	855	950
50	20	297	445	594	742	891	1039	1187	1336	1484
63	20	505	757	1009	1261	1514	1766	2018	2270	2523
80	25	816	1225	1633	2041	2449	2857	3266	3674	4082
100	25	1325	1988	2650	3313	3976	4640	5300	5965	6625

CN4 - TIE ROD PNEUMATIC CYLINDER ISO 6431 MODEL CHART

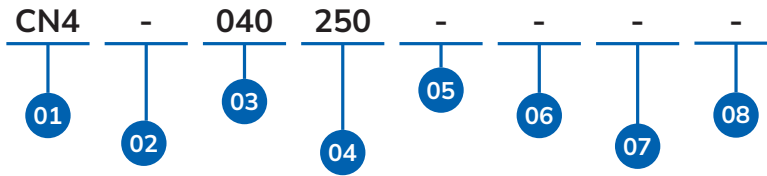

01	SERIES
CN4	

02	PRODUCT TYPE
-	Tie Rod Cylinder
M	Magnetic Tie Rod Cylinder
D	Tie Rod Double end Cylinder
R	Magnetic Tie Rod Double end Cylinder

03	BORE Ø (mm)
032	32
040	40
050	50
063	63
080	80
100	100

04	STROKE (mm)
010	10
025	25
040	40
050	50
...	...
250	250
...	...
1600	1600

05	SEAL MATERIAL
-	NBR
V	VITON

06	OPTIONAL
-	SS 420
S	Piston Rod SS304

07	CONFIGURATION
-	REGULAR
C1	CONFIG 1
...	...
C9	CONFIG 9
CA	CONFIG 10
CB	CONFIG 11

08	VERSION
-	VERSION 0
V1	VERSION 1
V2	VERSION 2
V3	VERSION 3
...	...
V9	VERSION 9
VA	VERSION 10
VB	VERSION 11

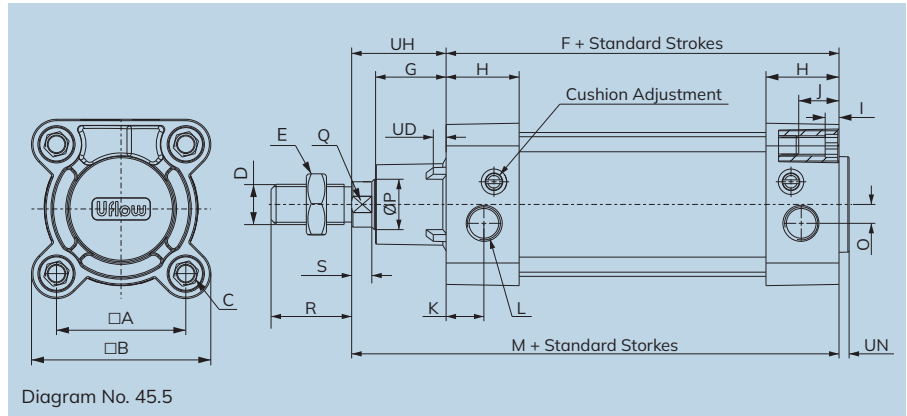

Specifications

Cylinder bore Ø (mm) :	32	40	50	63	80	100
Cushion stroke (mm) :	21	23	23	23	28	28
Standard strokes (mm):	25, 50, 80, 100, 125, 160, 200, 250, 300, 320, 400, 500					
Media :	Compressed air - filtered - lubricated					
Working pressure :	0.5 - 10 bar					
Medium temperature :	Regular +5°C to +60°C		High temperature applications +5°C to +150°C Max			
Materials of Construction :	Aluminium, Brass, Steel, Acetal, Polyurethane (Regular), Nitrile.					
Mountings :	Foot Mounting, Front Flange, Rear Flange, Male Clevis, Female Clevis, Female Clevis (king Pin), Center Trunnion, Front Trunnion , Rear Trunnion					
Accessories :	Clevis Foot Bracket, Wall Mounting Bracket, Trunnion Bracket, Rod End Fork, Rod End Aligner, Rod End Spherical Eye					

Features

- Adjustable cushioning at both ends with elastomer pads.
- Wide varieties of mountings.
- Optional - High temperature (Viton seals) 150°C max.
- Optional - Non corrosive stainless steel piston rod and piston rod lock nut (SS304)

Technical Data

All Dimension in mm

Cylinder bore Ø	A	B	C	D	E	F + TOL	G	H	I	J	K	L	M + TOL	UN	O	P	Q	R	S	ØT	UD	UH + TOL	Stroke tol			
32	32.5	45	M6	M10X1.25	17	94	±0.6	18.5	25.5	5	16	13	G ¹ / ₈	120	±1	4	5	12	10	22	6	30	6	26	+2	
40	38	51	M6	M12X1.25	19	105		20.5	29	5	16	14.5	G ¹ / ₄	135		4	5	16	13	24	6.5	35	6.5	30	±1.3	+0
50	46.5	64	M8	M16X1.5	24	106	±0.7	28	29	6	16	15	G ¹ / ₄	143		4	7.5	20	16	32	8	40	6.5	37		
63	56.5	74	M8	M16X1.5	24	121		27.5	35	6	16	17	G ³ / ₈	158		4	10	20	16	32	8	45	6.5	37		
80	72	94	M10	M20X1.5	30	128	±0.8	34	35	6	16	18	G ³ / ₈	174	±1.1	4	14	25	21	40	10	45	6.5	46	±1.5	+2.5
100	89	111	M10	M20X1.5	30	138		35	38.5	6	16	18	G ¹ / ₂	189		4	10	25	21	40	10	55	6.5	51		+0

Output Force

(Force in N : 1N = 0.1 kgf)

Cylinder bore Ø (mm)	Rod Ø (mm)		Working pressure in bar								
			2	3	4	5	6	7	8	9	10
32	12	Extend	145	217	289	362	434	507	579	651	724
		Retract	124	187	249	311	373	435	498	559	621
40	16	Extend	226	339	452	565	678	792	905	1018	1130
		Retract	190	285	380	475	570	665	760	855	950
50	20	Extend	353	530	706	884	1060	1237	1414	1590	1767
		Retract	297	445	594	742	891	1039	1187	1336	1484
63	20	Extend	561	842	1122	1403	1683	1964	2244	2525	2805
		Retract	505	757	1009	1261	1514	1766	2018	2270	2523
80	25	Extend	905	1357	1809	2262	2714	3167	3619	4072	4524
		Retract	816	1225	1633	2041	2449	2857	3266	3674	4082
100	25	Extend	1414	2120	2828	3534	4241	4948	5655	6362	7069
		Retract	1325	1988	2650	3313	3976	4640	5300	5965	6625

PU Pneumatic Cylinder Double End Double Acting - PS4 Series

(As Per ISO 15552 / VDMA 24562 Standards)

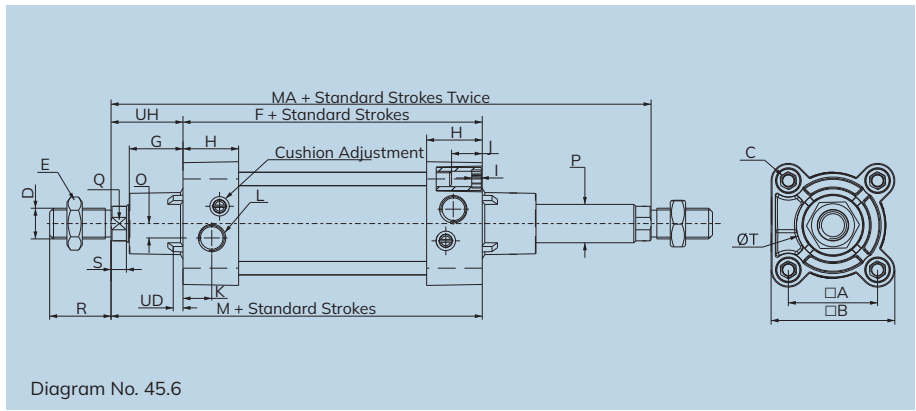

Specifications

Cylinder Bore Ø (mm) :	32	40	50	63	80	100
Cushion Stroke (mm) :	21	23	23	23	28	28
Standard Strokes (mm):	25, 50, 80, 100, 125, 160, 200, 250, 300, 320, 400, 500					
Media :	Compressed air - filtered - lubricated					
Working Pressure :	0.5 - 10 bar					
Medium Temperature :	Regular +5°C to +60°C		High Temperature Applications +5°C to +150°C Max			
Materials of Construction :	Aluminium, Brass, Steel, Acetal, Polyurethane (Regular), Nitrile.					
Mountings	Foot Mounting, Flange, Female Clevis, Front Trunnion, Center Trunnion					
Accessories	Clevis Foot Bracket, Wall Mounting Bracket, Trunnion Bracket, Rod End Fork, Rod End Aligner, Rod End Spherical Eye					

Features

- Adjustable cushioning at both ends with pads.
- Wide varieties of mountings.
- Optional - High temperature (Viton seals) 150°C max.
- Optional - Non corrosive stainless steel piston rod and piston rod lock nut (SS304)

Technical Data

All Dimension in mm

Cylinder bore Ø	A	B	C	D	E	F + TOL	G	H	I	J	K	L	M + TOL	MA + TOL	O	P	Q	R	S	ØT	UD	UH + TOL	Stroke tol		
32	32.5	45	M6	M10X1.25	17	94		18.5	25.5	5	16	13	G $\frac{3}{4}$	120		5	12	10	22	6	30	6	26		
40	38	51	M6	M12X1.25	19	105	±0.6	20.5	29	5	16	14.5	G $\frac{3}{4}$	135		5	16	13	24	6.5	35	6.5	30	±1.3	+2 0
50	46.5	64	M8	M16X1.5	24	106	±0.7	28	29	6	16	15	G $\frac{3}{4}$	143		7.5	20	16	32	8	40	6.5	37		
63	56.5	74	M8	M16X1.5	24	121		27.5	35	6	16	17	G $\frac{3}{4}$	158		10	20	16	32	8	45	6.5	37		
80	72	94	M10	M20X1.5	30	128	±0.8	34	35	6	16	18	G $\frac{3}{4}$	174		14	25	21	40	10	45	6.5	46	±1.5	+2.5 0
100	89	111	M10	M20X1.5	30	138		35	38.5	6	16	18	G $\frac{1}{2}$	189		10	25	21	40	10	55	6.5	51		

Output Force

(Force in N : 1N = 0.1 kgf)

Cylinder bore Ø (mm)	Rod Ø (mm)	Working pressure in bar									
		2	3	4	5	6	7	8	9	10	
32	12	124	187	249	311	373	435	498	559	621	
40	16	190	285	380	475	570	665	760	855	950	
50	20	297	445	594	742	891	1039	1187	1336	1484	
63	20	505	757	1009	1261	1514	1766	2018	2270	2523	
80	25	816	1225	1633	2041	2449	2857	3266	3674	4082	
100	25	1325	1988	2650	3313	3976	4640	5300	5965	6625	

PS4 - PU SERIES TIE ROD PNEUMATIC CYLINDER ISO 1552 MODEL CHART

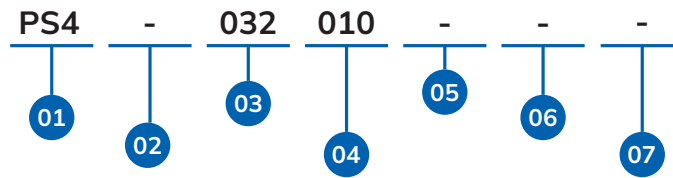

01	SERIES
PS4	

02	PRODUCT TYPE
-	Tie Rod Cylinder
M	Magnetic Tie Rod Cylinder
D	Tie Rod Double end Cylinder
R	Magnetic Tie Rod Double end Cylinder

03	BORE Ø (mm)
032	32
040	40
050	50
063	63
080	80
100	100
125	125

04	STROKE (MM)
010	10
025	25
040	40
050	50
⋮	⋮
1600	1600

05	OPTIONAL
-	SS 420
S	Piston Rod SS304

06	CONFIGURATION
-	REGULAR
C1	CONFIG 1
C2	CONFIG 2
C3	CONFIG 3
⋮	⋮
C9	CONFIG 9
CA	CONFIG 10
CB	CONFIG 11

07	VERSION
-	VERSION 0
V1	VERSION 1
V2	VERSION 2
V3	VERSION 3
⋮	⋮
V9	VERSION 9
VA	VERSION 10
VB	VERSION 11

PS4-050025
PU TIE ROD CYLINDER OD 50-STROKE 25-NBR-SS 420

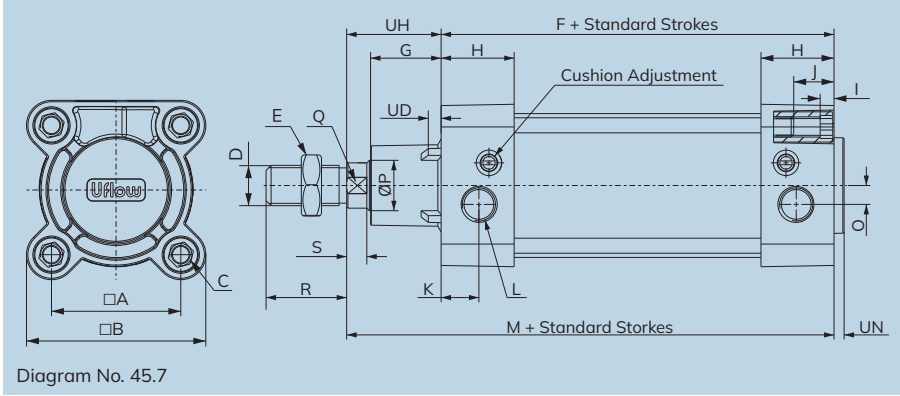
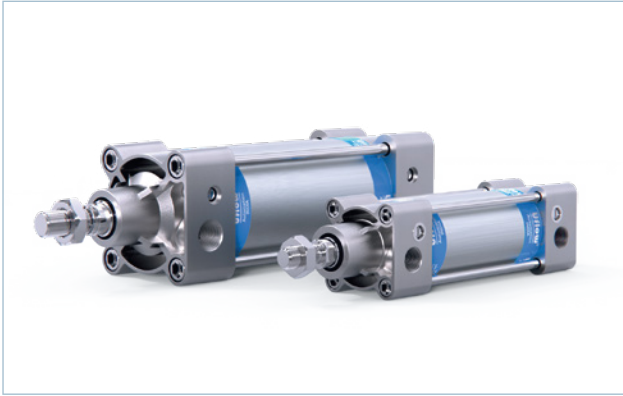

Specifications

Cylinder bore Ø (mm) :	32	40	50	63	80	100
Cushion stroke (mm) :	21	23	23	23	28	28
Standard strokes (mm):	25, 50, 80, 100, 125, 160, 200, 250, 300, 320, 400, 500					
Media :	Compressed air - filtered - lubricated					
Working pressure :	0.5 - 10 bar					
Medium temperature :	Regular +5°C to +60°C		High temperature applications +5°C to +150°C Max			
Materials of Construction :	Aluminium, Brass, Steel, Acetal, Polyurethane (Regular), Nitrile.					
Mountings	Foot Mounting, Front Flange, Rear Flange, Male Clevis, Female Clevis, Female Clevis (king Pin), Center Trunnion, Front Trunnion, Rear Trunnion					
Accessories	Clevis Foot Bracket, Wall Mounting Bracket, Trunnion Bracket, Rod End Fork, Rod End Aligner, Rod End Spherical Eye					

Features

- Adjustable cushioning at both ends with elastomer pads.
- Wide varieties of mountings.
- Optional - High temperature (Viton seals) 150°C max.
- Optional - Non corrosive stainless steel piston rod and piston rod lock nut (SS304)

Technical Data

All Dimension in mm

Cylinder bore Ø	A	B	C	D	E	F + TOL	G	H	I	J	K	L	M + TOL	UN	O	P	Q	R	S	ØT	UD	UH + TOL	Stroke tol			
32	32	44	M6	M10X1.25	17	94		20.5	25	5	16	8.5	G ³ / ₄	120	±1	4	0	12	10	22	6	30	6	26		
40	40	55	M6	M12X1.25	19	105	±0.6	24.5	28	5	16	12	G ³ / ₄	135		4	3	16	13	24	6.5	35	6.5	30	±1.3	+2
50	48	63	M8	M16X1.5	24	106	±0.7	30	30	6	16	12	G ³ / ₄	143		4	5	20	16	32	8	40	6.5	37		+0
63	60	83	M8	M16X1.5	24	121		30.5	33	6	16	16.5	G ³ / ₄	158	±1.1	4	10	20	16	32	8	45	6.5	37		+2.5
80	72	98	M10	M20X1.5	30	128	±0.8	38.5	33	6	16	16	G ³ / ₄	174		4	15	25	21	40	10	45	6.5	46	±1.5	+0
100	89	115	M10	M20X1.5	30	138		44	37	6	16	18	G ¹ / ₂	189		4	15	25	21	40	10	55	6.5	51		

Output Force

(Force in N : 1N = 0.1 kgf)

Cylinder bore Ø (mm)	Rod Ø (mm)		Working pressure in bar									
			2	3	4	5	6	7	8	9	10	
32	12	Extend	145	217	289	362	434	507	579	651	724	
		Retract	124	187	249	311	373	435	498	559	621	
40	16	Extend	226	339	452	565	678	792	905	1018	1130	
		Retract	190	285	380	475	570	665	760	855	950	
50	20	Extend	353	530	706	884	1060	1237	1414	1590	1767	
		Retract	297	445	594	742	891	1039	1187	1336	1484	
63	20	Extend	561	842	1122	1403	1683	1964	2244	2525	2805	
		Retract	505	757	1009	1261	1514	1766	2018	2270	2523	
80	25	Extend	905	1357	1809	2262	2714	3167	3619	4072	4524	
		Retract	816	1225	1633	2041	2449	2857	3266	3674	4082	
100	25	Extend	1414	2120	2828	3534	4241	4948	5655	6362	7069	
		Retract	1325	1988	2650	3313	3976	4640	5300	5965	6625	

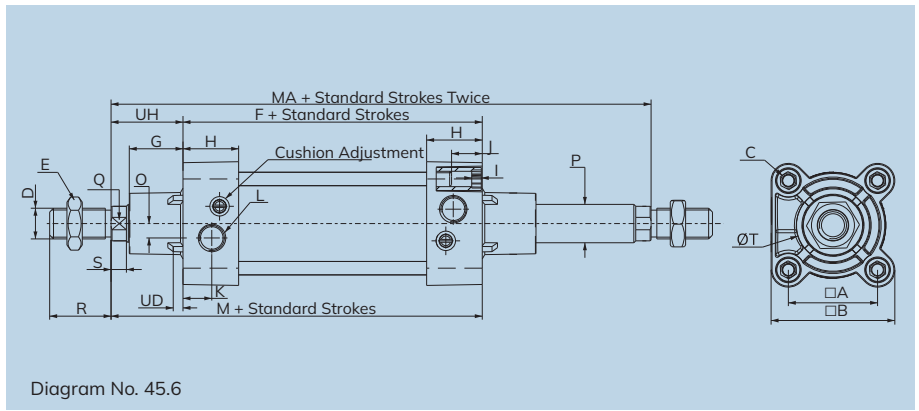

Specifications

Cylinder Bore Ø (mm) :	32	40	50	63	80	100
Cushion Stroke (mm) :	21	23	23	23	28	28
Standard Strokes (mm):	25, 50, 80, 100, 125, 160, 200, 250, 300, 320, 400, 500					
Media :	Compressed air - filtered - lubricated					
Working Pressure :	0.5 - 10 bar					
Medium Temperature :	Regular +5°C to +60°C		High Temperature Applications +5°C to +150°C Max			
Materials of Construction :	Aluminium, Brass, Steel, Acetal, Polyurethane (Regular), Nitrile.					
Mountings	Foot Mounting, Flange, Female Clevis, Front Trunnion, Center Trunnion					
Accessories	Clevis Foot Bracket, Wall Mounting Bracket, Trunnion Bracket, Rod End Fork, Rod End Aligner, Rod End Spherical Eye					

Features

- Adjustable cushioning at both ends with pads.
- Wide varieties of mountings.
- Optional - High temperature (Viton seals) 150°C max.
- Optional - Non corrosive stainless steel piston rod and piston rod lock nut (SS304)

Technical Data

Cylinder bore Ø	A	B	C	D	E	F + TOL	G	H	I	J	K	L	M + TOL	MA + TOL	O	P	Q	R	S	ØT	UD	UH + TOL	Stroke tol	
	32	32.5	45	M6	M10X1.25	17	94 ±0.6	18.5	25.5	5	16	13	G½	120 ±1	147	5	12	10	22	6	30	6	26	+2
40	38	51	M6	M12X1.25	19	105 ±0.6	20.5	29	5	16	14.5	G¼	135 ±1	166	5	16	13	24	6.5	35	6.5	30	±1.3	0
50	46.5	64	M8	M16X1.5	24	106 ±0.7	28	29	6	16	15	G¼	143 ±1.1	181	±1.5	7.5	20	16	32	8	40	6.5	37	+2.5
63	56.5	74	M8	M16X1.5	24	121 ±0.8	27.5	35	6	16	17	G¾	158 ±1.1	196	±1.5	10	20	16	32	8	45	6.5	37	0
80	72	94	M10	M20X1.5	30	128 ±0.8	34	35	6	16	18	G¾	174 ±1.1	221	±1.5	14	25	21	40	10	45	6.5	46	±1.5
100	89	111	M10	M20X1.5	30	138 ±0.8	35	38.5	6	16	18	G½	189 ±1.1	241	±1.5	10	25	21	40	10	55	6.5	51	0

Output Force

(Force in N : 1N = 0.1 kgf)

Cylinder bore Ø (mm)	Rod Ø (mm)	Working pressure in bar								
		2	3	4	5	6	7	8	9	10
32	12	124	187	249	311	373	435	498	559	621
40	16	190	285	380	475	570	665	760	855	950
50	20	297	445	594	742	891	1039	1187	1336	1484
63	20	505	757	1009	1261	1514	1766	2018	2270	2523
80	25	816	1225	1633	2041	2449	2857	3266	3674	4082
100	25	1325	1988	2650	3313	3976	4640	5300	5965	6625

PN4 - PU TIE ROD PNEUMATIC CYLINDER ISO 6431 MODEL CHART

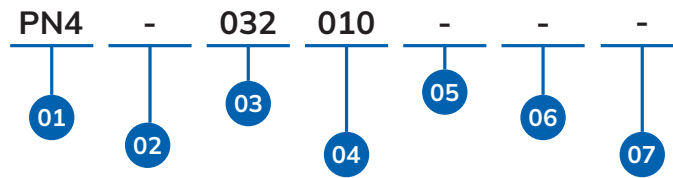

01	SERIES
PN4	

02	PRODUCT TYPE
-	Tie Rod Cylinder
M	Magnetic Tie Rod Cylinder
D	Tie Rod Double end Cylinder
R	Magnetic Tie Rod Double end Cylinder

03	BORE Ø (mm)
032	32
040	40
050	50
063	63
080	80
100	100

04	STROKE (MM)
010	10
025	25
040	40
050	50
⋮	⋮
1600	1600

05	OPTIONAL
-	SS 420
S	Piston Rod SS304

06	CONFIGURATION
-	REGULAR
C1	CONFIG 1
C2	CONFIG 2
C3	CONFIG 3
⋮	⋮
C9	CONFIG 9
CA	CONFIG 10
CB	CONFIG 11

07	VERSION
-	VERSION 0
V1	VERSION 1
V2	VERSION 2
V3	VERSION 3
⋮	⋮
V9	VERSION 9
VA	VERSION 10
VB	VERSION 11

PN4-032010
TIE ROD CYLINDER OD 32-STROKE 10-NBR-SS304

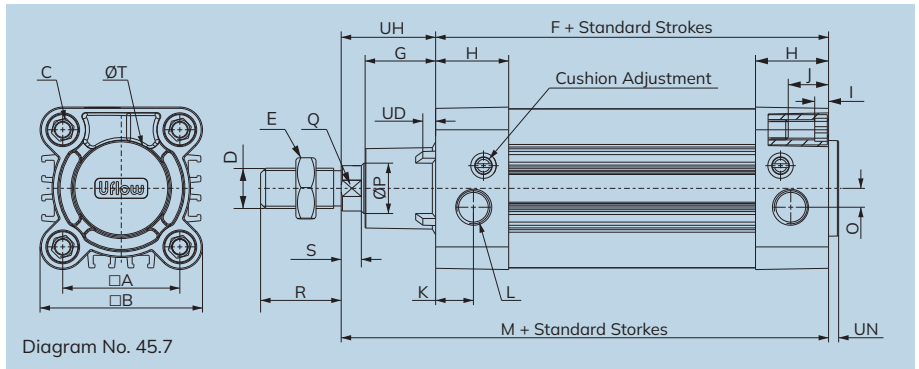
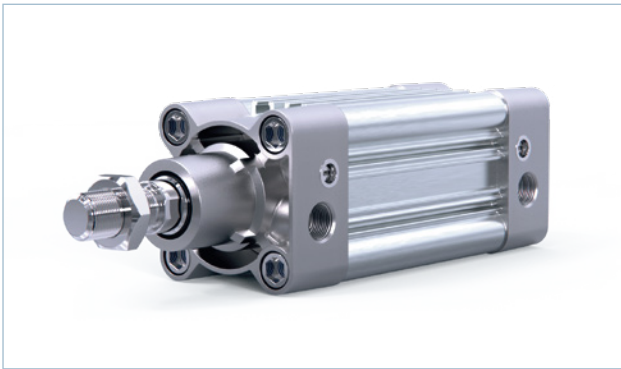

Specifications

Cylinder Bore Ø (mm) :	32	40	50	63	80	100	125
Cushion Stroke (mm) :	21	23	23	23	28	28	40
Standard Strokes (mm):	25, 50, 80, 100, 125, 160, 200, 250, 300, 320, 400, 500						50, 80, 100, 125, 160, 200
Media :	Compressed air - filtered - lubricated						250, 300, 320, 400, 500
Working Pressure :	0.5 - 10 bar						
Medium Temperature :	Regular			High temperature applications			
	5°C - 60°C			5°C - 150°C Max			
Materials of Construction :	Aluminium, Brass, Steel, Acetal, Polyurethane, Nitrile (Regular), FKM (High temperature)						
Mountings :	Foot Mounting, Front Flange, Rear Flange, Male Clevis, Male Clevis (with Spherical Bearing), Female Clevis, Female Clevis (king Pin), Front Trunnion, Rear Trunnion						
Accessories :	Clevis Foot Bracket, Clevis Foot Bracket (spherical), Wall Mounting Bracket, Trunnion Bracket, Rod End Fork, Rod End Aligner, Rod End Spherical Eye						

Features

- Adjustable cushioning at both ends with pads.
- Wide varieties of mountings.
- Optional - High temperature (Viton seals) 150°C max.
- Optional - Non corrosive stainless steel piston rod and piston rod lock nut (SS304)

Technical Data

All Dimension in mm

Cylinder bore Ø	A	B	C	D	E	F + TOL	G	H	I	J	K	L	M + TOL	UN	O	P	Q	R	S	ØT	UD	UH + TOL	Stroke tol			
32	32.5	45	M6	M10X1.25	17	94	±0.6	18.5	25.5	5	16	13	G½	120	±1	4	5	12	10	22	6	30	6	26		
40	38	51	M6	M12X1.25	19	105	±0.6	20.5	29	5	16	14.5	G¾	135	±1	4	5	16	13	24	6.5	35	6.5	30	±1.3	+2
50	46.5	64	M8	M16X1.5	24	106	±0.7	28	29	6	16	15	G¾	143	±1.1	4	7.5	20	16	32	8	40	6.5	37		
63	56.5	74	M8	M16X1.5	24	121	±0.8	27.5	35	6	16	17	G¾	158	±1.1	4	10	20	16	32	8	45	6.5	37		
80	72	94	M10	M20X1.5	30	128	±0.8	34	35	6	16	18	G¾	174	±1.1	4	14	25	21	40	10	45	6.5	46	±1.5	+2.5
100	89	111	M10	M20X1.5	30	138	±0.8	35	38.5	6	16	18	G½	189	±1.2	4	10	25	21	40	10	55	6.5	51		
125	110	136	M12	M20X1.5	41	160	±1	49	44	-	20	20	G½	225	±1.2	6	12	32	27	54	13	60	10	5	±2.2	+4

Output Force

(Force in N : 1N = 0.1 kgf)

Cylinder bore Ø (mm)	Rod Ø (mm)		Working pressure in bar									
			2	3	4	5	6	7	8	9	10	
32	12	Extend	145	217	289	362	434	507	579	651	724	
		Retract	124	187	249	311	373	435	498	559	621	
40	16	Extend	226	339	452	565	678	792	905	1018	1130	
		Retract	190	285	380	475	570	665	760	855	950	
50	20	Extend	353	530	706	884	1060	1237	1414	1590	1767	
		Retract	297	445	594	742	891	1039	1187	1336	1484	
63	20	Extend	561	842	1122	1403	1683	1964	2244	2525	2805	
		Retract	505	757	1009	1261	1514	1766	2018	2270	2523	
80	25	Extend	905	1357	1809	2262	2714	3167	3619	4072	4524	
		Retract	816	1225	1633	2041	2449	2857	3266	3674	4082	
100	25	Extend	1414	2120	2828	3534	4241	4948	5655	6362	7069	
		Retract	1325	1988	2650	3313	3976	4640	5300	5965	6625	
125	32	Extend	2209	3313	4417	5522	6626	7731	8835	9940	11044	
		Retract	2064	3096	4128	5160	6192	7224	8256	9288	10320	

Pneumatic Profile Cylinder Double End Double Acting - CS7 Series

(As Per ISO 15552 / VDMA 24562 Standards)

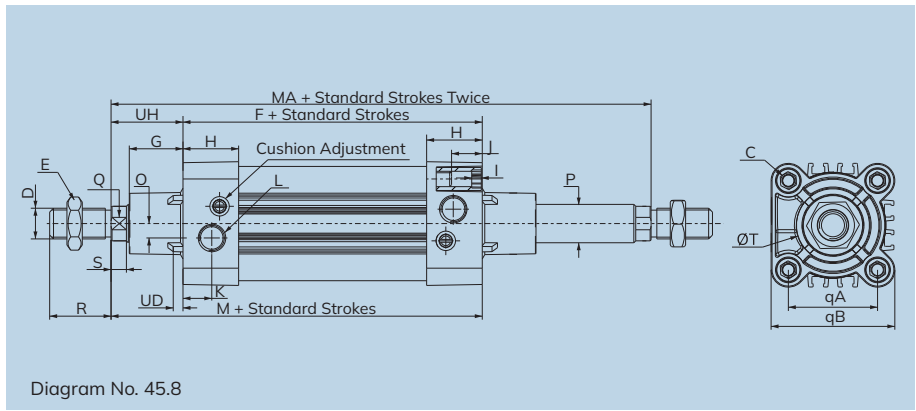

Specifications

Cylinder Bore Ø (mm) :	32	40	50	63	80	100	125
Cushion Stroke (mm) :	21	23	23	23	28	28	40
Standard Strokes (mm):	25, 50, 80, 100, 125, 160, 200, 250, 300, 320, 400, 500			50, 80, 100, 125, 160, 200, 250, 300, 320, 400, 500			
Media :	Compressed air - filtered - lubricated						
Working Pressure :	0.5 - 10 bar						
Medium Temperature :	Regular +5°C to +60°C		High Temperature Applications +5°C to +150°C Max				
Materials of Construction :	Aluminium, Brass, Steel, Acetal, Polyurethane, Nitrile (Regular), FKM (High temperature)						
Mountings	Foot Mounting, Flange, Female Clevis, Front & Rear Trunnion, Center Trunnion						
Accessories	Clevis Foot Bracket, Wall Mounting Bracket, Trunnion Bracket, Rod End Fork, Rod End Aligner, Rod End Spherical Eye						

Features

- Adjustable cushioning at both ends with pads.
- Wide varieties of mountings.
- Optional - High temperature (Viton seals) 150°C max.
- Optional - Non corrosive stainless steel piston rod and piston rod lock nut (SS304)

Technical Data

All Dimension in mm

Cylinder bore Ø	A	B	C	D	E	F + TOL	G	H	I	J	K	L	M + TOL	MA + TOL	O	P	Q	R	S	ØT	UD	UH + TOL	Stroke tol	
32	32.5	45	M6	M10X1.25	17	94 ±0.6	18.5	25.5	5	16	13	G½	120 ±1	147	5	12	10	22	6	30	6	26	+2	
40	38	51	M6	M12X1.25	19	105 ±0.6	20.5	29	5	16	14.5	G¼	135 ±1	166	5	16	13	24	6.5	35	6.5	30	±1.3	0
50	46.5	64	M8	M16X1.5	24	106 ±0.7	28	29	6	16	15	G¼	143 ±1.5	181	7.5	20	16	32	8	40	6.5	37	+2.5	
63	56.5	74	M8	M16X1.5	24	121 ±0.8	27.5	35	6	16	17	G¾	158 ±1.1	196	10	20	16	32	8	45	6.5	37	0	
80	72	94	M10	M20X1.5	30	128 ±0.8	34	35	6	16	18	G¾	174 ±1.1	221	14	25	21	40	10	45	6.5	46	±1.5	+2.5
100	89	111	M10	M20X1.5	30	138 ±1	35	38.5	6	16	18	G½	189 ±1.2	241	10	25	21	40	10	55	6.5	51	0	
125	110	136	M12	M27X2	41	160 ±1	48.5	44	6	20	20	G½	225 ±1.2	292 ±2	12	32	32	54	13	60	10	66	±2.2	+4

Output Force

(Force in N : 1N = 0.1 kgf)

Cylinder bore Ø (mm)	Rod Ø (mm)	Working pressure in bar									
		2	3	4	5	6	7	8	9	10	
32	12	124	187	249	311	373	435	498	559	621	
40	16	190	285	380	475	570	665	760	855	950	
50	20	297	445	594	742	891	1039	1187	1336	1484	
63	20	505	757	1009	1261	1514	1766	2018	2270	2523	
80	25	816	1225	1633	2041	2449	2857	3266	3674	4082	
100	25	1325	1988	2650	3313	3976	4640	5300	5965	6625	
125	32	2064	3096	4128	5160	6192	7224	8256	9288	10320	

CS7 - SERIES PROFILE PNEUMATIC CYLINDER ISO 1552 MODEL CHART

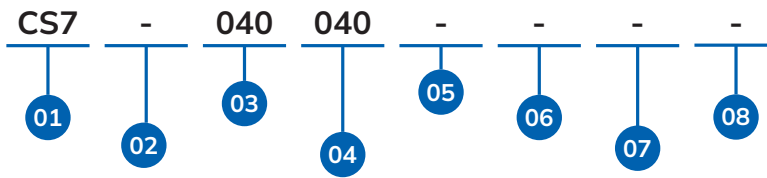

01	SERIES
	CS7

02	PRODUCT TYPE
-	Profile Cylinder
M	Magnetic Profile Cylinder
D	Profile Double End Cylinder
R	Magnetic Profile Double End Cylinder

03	BORE Ø (mm)
032	32
040	40
050	50
063	63
080	80
100	100
125	125

04	STROKE (mm)
010	10
025	25
040	40
050	50
⋮	⋮
1600	1600

05	SEAL MATERIAL
-	NBR
V	VITON

06	OPTIONAL
-	SS 420
S	Piston Rod SS304

07	CONFIGURATION
-	REGULAR
C1	CONFIG 1
⋮	⋮
C9	CONFIG 9
CA	CONFIG 10
CB	CONFIG 11

08	VERSION
-	VERSION 0
V1	VERSION 1
V2	VERSION 2
V3	VERSION 3
⋮	⋮
V9	VERSION 9
VA	VERSION 10
VB	VERSION 11

CS7-040040
PROFILE CYLINDER OD 40-STROKE 40-NBR-SS 420

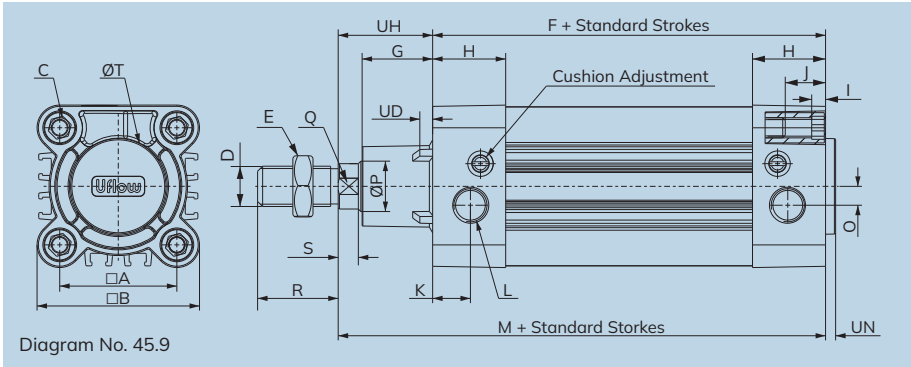
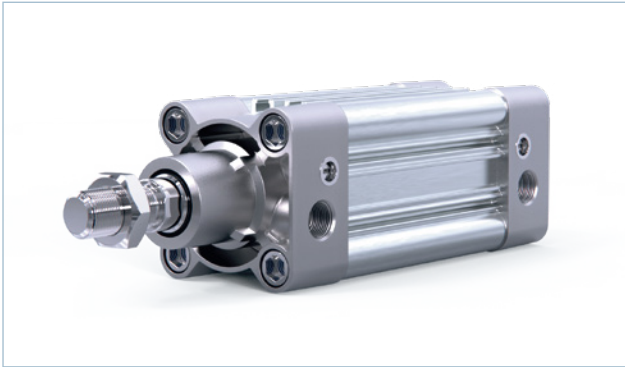

Diagram No. 45.9

Specifications

Cylinder Bore Ø (mm) :	32	40	50	63	80	100	125
Cushion Stroke (mm) :	21	23	23	23	28	28	40
Standard Strokes (mm):	25, 50, 80, 100, 125, 160, 200, 250, 300, 320, 400, 500						50, 80, 100, 125, 160, 200
Media :	Compressed air - filtered - lubricated						250, 300, 320, 400, 500
Working Pressure :	0.5 - 10 bar						
Medium Temperature :	Regular			High temperature applications			
	5°C - 60°C			5°C - 150°C Max			
Materials of Construction :	Aluminium, Brass, Steel, Acetal, Polyurethane (Regular), Nitrile						
Mountings :	Foot Mounting, Front Flange, Rear Flange, Male Clevis, Male Clevis (with Spherical Bearing), Female Clevis, Female Clevis (king Pin), Front Trunnion, Rear Trunnion						
Accessories :	Clevis Foot Bracket, Clevis Foot Bracket (spherical), Wall Mounting Bracket, Trunnion Bracket, Rod End Fork, Rod End Aligner, Rod End Spherical Eye						

Features

- Adjustable cushioning at both ends with pads.
- Wide varieties of mountings.
- Optional - High temperature (Viton seals) 150°C max.
- Optional - Non corrosive stainless steel piston rod and piston rod lock nut (SS304)

Technical Data

All Dimension in mm

Cylinder bore Ø	A	B	C	D	E	F + TOL	G	H	I	J	K	L	M + TOL	UN	O	P	Q	R	S	ØT	UD	UH + TOL	Stroke tol			
32	32.5	45	M6	M10X1.25	17	94		18.5	25.5	5	16	13	G ¹ / ₂	120		4	5	12	10	22	6	30	6	26		
40	38	51	M6	M12X1.25	19	105	±0.6	20.5	29	5	16	14.5	G ³ / ₄	135	±1	4	5	16	13	24	6.5	35	6.5	30	±1.3	+2
50	46.5	64	M8	M16X1.5	24	106	±0.7	28	29	6	16	15	G ¹ / ₄	143		4	7.5	20	16	32	8	40	6.5	37		
63	56.5	74	M8	M16X1.5	24	121		27.5	35	6	16	17	G ³ / ₈	158		4	10	20	16	32	8	45	6.5	37		
80	72	94	M10	M20X1.5	30	128	±0.8	34	35	6	16	18	G ³ / ₈	174	±1.1	4	14	25	21	40	10	45	6.5	46	±1.5	+2.5
100	89	111	M10	M20X1.5	30	138		35	38.5	6	16	18	G ¹ / ₂	189		4	10	25	21	40	10	55	6.5	51		
125	110	136	M12	M20X1.5	41	160	±1	49	44	-	20	20	G ¹ / ₂	225	±1.2	6	12	32	27	54	13	60	10	5	±2.2	+4

Output Force

(Force in N : 1N = 0.1 kgf)

Cylinder bore Ø (mm)	Rod Ø (mm)		Working pressure in bar									
			2	3	4	5	6	7	8	9	10	
32	12	Extend	145	217	289	362	434	507	579	651	724	
		Retract	124	187	249	311	373	435	498	559	621	
40	16	Extend	226	339	452	565	678	792	905	1018	1130	
		Retract	190	285	380	475	570	665	760	855	950	
50	20	Extend	353	530	706	884	1060	1237	1414	1590	1767	
		Retract	297	445	594	742	891	1039	1187	1336	1484	
63	20	Extend	561	842	1122	1403	1683	1964	2244	2525	2805	
		Retract	505	757	1009	1261	1514	1766	2018	2270	2523	
80	25	Extend	905	1357	1809	2262	2714	3167	3619	4072	4524	
		Retract	816	1225	1633	2041	2449	2857	3266	3674	4082	
100	25	Extend	1414	2120	2828	3534	4241	4948	5655	6362	7069	
		Retract	1325	1988	2650	3313	3976	4640	5300	5965	6625	
125	32	Extend	2209	3313	4417	5522	6626	7731	8835	9940	11044	
		Retract	2064	3096	4128	5160	6192	7224	8256	9288	10320	

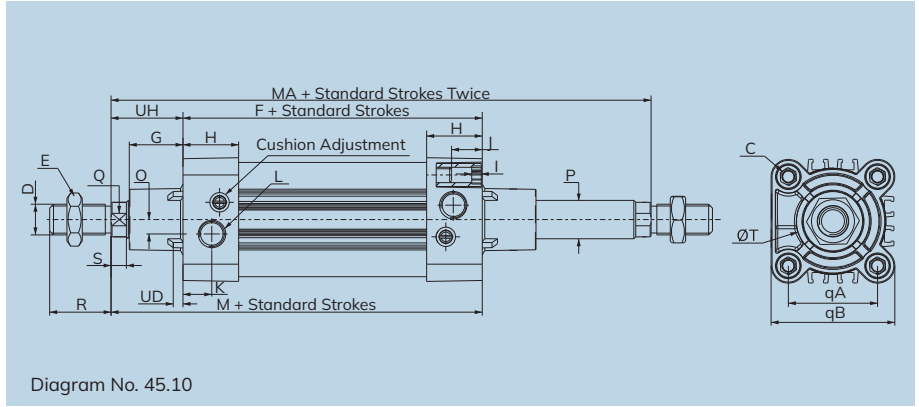

Specifications

Cylinder Bore Ø (mm) :	32	40	50	63	80	100	125
Cushion Stroke (mm) :	21	23	23	23	28	28	40
Standard Strokes (mm):	25, 50, 80, 100, 125, 160, 200, 250, 300, 320, 400, 500						50, 80, 100, 125, 160, 200, 250, 300, 320, 400, 500
Media :	Compressed air - filtered - lubricated						
Working Pressure :	0.5 - 10 bar						
Medium Temperature :	Regular +5°C to +60°C		High Temperature Applications +5°C to +150°C Max				
Materials of Construction :	Aluminium, Brass, Steel, Acetal, Polyurethane (Regular), Nitrile						
Mountings	Foot Mounting, Flange, Female Clevis, Front & Rear Trunnion, Center Trunnion						
Accessories	Clevis Foot Bracket, Wall Mounting Bracket, Trunnion Bracket, Rod End Fork, Rod End Aligner, Rod End Spherical Eye						

Features

- Adjustable cushioning at both ends with pads.
- Wide varieties of mountings.
- Optional - High temperature (Viton seals) 150°C max.
- Optional - Non corrosive stainless steel piston rod and piston rod lock nut (SS304)

Technical Data

All Dimension in mm

Cylinder bore Ø	A	B	C	D	E	F + TOL	G	H	I	J	K	L	M + TOL	MA + TOL	O	P	Q	R	S	ØT	UD	UH + TOL	Stroke tol
32	32.5	45	M6	M10X1.25	17	94 ±0.6	18.5	25.5	5	16	13	G ¹ / ₈	120 ±1	147	5	12	10	22	6	30	6	26	+2
40	38	51	M6	M12X1.25	19	105 ±0.6	20.5	29	5	16	14.5	G ¹ / ₈	135 ±1	166	5	16	13	24	6.5	35	6.5	30 ±1.3	0
50	46.5	64	M8	M16X1.5	24	106 ±0.7	28	29	6	16	15	G ¹ / ₈	143 ±1.5	181	7.5	20	16	32	8	40	6.5	37	+2.5
63	56.5	74	M8	M16X1.5	24	121 ±0.8	27.5	35	6	16	17	G ³ / ₈	158 ±1.1	196	10	20	16	32	8	45	6.5	37	0
80	72	94	M10	M20X1.5	30	128 ±0.8	34	35	6	16	18	G ³ / ₈	174 ±1.1	221	14	25	21	40	10	45	6.5	46 ±1.5	+2.5
100	89	111	M10	M20X1.5	30	138 ±0.8	35	38.5	6	16	18	G ¹ / ₂	189 ±1.2	241	10	25	21	40	10	55	6.5	51 ±1.5	0
125	110	136	M12	M27X2	41	160 ±1	48.5	44	6	20	20	G ¹ / ₂	225 ±1.2	292 ±2	12	32	32	54	13	60	10	66 ±2.2	+4

Output Force

(Force in N : 1N = 0.1 kgf)

Cylinder bore Ø (mm)	Rod Ø (mm)	Working pressure in bar									
		2	3	4	5	6	7	8	9	10	
32	12	124	187	249	311	373	435	498	559	621	
40	16	190	285	380	475	570	665	760	855	950	
50	20	297	445	594	742	891	1039	1187	1336	1484	
63	20	505	757	1009	1261	1514	1766	2018	2270	2523	
80	25	816	1225	1633	2041	2449	2857	3266	3674	4082	
100	25	1325	1988	2650	3313	3976	4640	5300	5965	6625	
125	32	2064	3096	4128	5160	6192	7224	8256	9288	10320	

PS7 - PU SERIES PROFILE PNEUMATIC CYLINDER ISO 15552 MODEL CHART

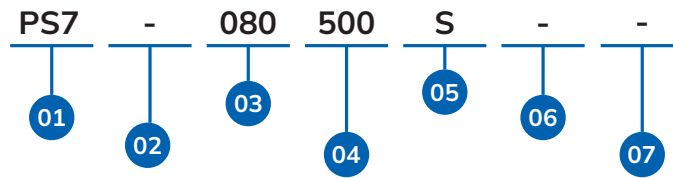

01	SERIES
PS7	

02	PRODUCT TYPE
-	Profile Cylinder
M	Magnetic Profile Cylinder
D	Profile Double End Cylinder
R	Magnetic Profile Double End Cylinder

03	BORE Ø (mm)
032	32
040	40
050	50
063	63
080	80
100	100
125	125

04	STROKE (MM)
010	10
025	25
040	40
050	50
...	...
500	500
...	...
1600	1600

05	OPTIONAL
-	SS 420
S	Piston Rod SS304

06	CONFIGURATION
-	REGULAR
C1	CONFIG 1
C2	CONFIG 2
C3	CONFIG 3
...	...
C9	CONFIG 9
CA	CONFIG 10
CB	CONFIG 11

07	VERSION
-	VERSION 0
V1	VERSION 1
V2	VERSION 2
V3	VERSION 3
...	...
V9	VERSION 9
VA	VERSION 10
VB	VERSION 11

PS7-080500S
PU PROFILE CYLINDER OD 80-STROKE 500-PU-PISTON ROD SS304

Note: The above chart is for identification purposes only, and it may not be possible to make all combinations for the above chart.

Foot Mounting

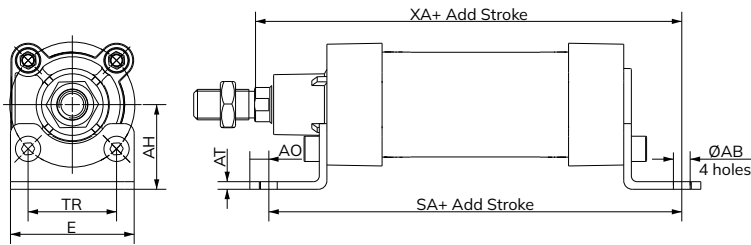

BORE DIA	TR (±0.3)	E	AT	AB (H14)	AO (MAX)	TG	AH	SA+	XA+	Bolt Size
32	32	46	4	7	8	32.5	33	138	142.8	M6
40	36	52	4	9	10	38	36	157	162.5	M8
50	45	65	4	9	10	46.5	45	167	174.5	M8
63	50	75	4	8.8	10	56.5	50	181.5	189	M8
80	63	95	5	12	13.5	72	63	207.5	214	M10
100	75	115	5	14	15.5	89	71	216.5	228	M12

Front Flange

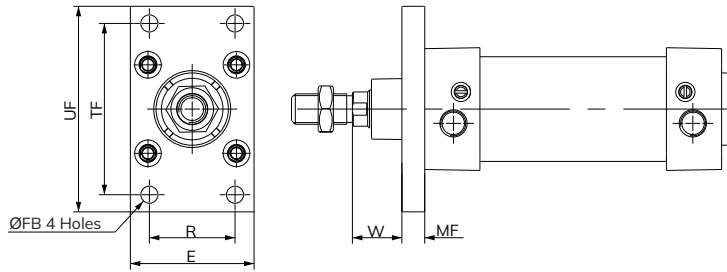

BORE DIA	TF (±0.3)	R (±0.3)	E	UF	MF	FB (DIA HOLE)	Bolt Size
32	64	32	47	80	10	7	M6
40	72	36	53	90	10	9	M8
50	90	45	65	108	12	9	M8
63	100	50	75	118	12	9	M8
80	126	63	95	150	16	12	M10
100	150	75	115	176	16	14	M12

Rear Flange

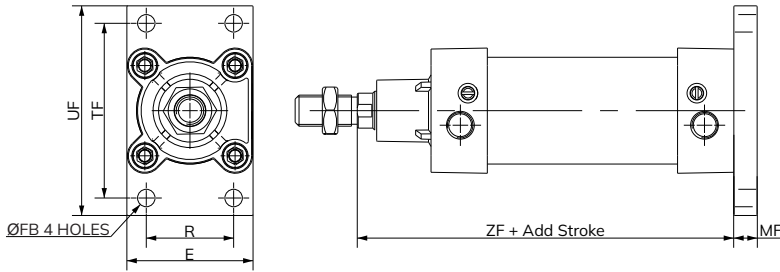

BORE DIA	TF (±0.3)	R (±0.3)	E	UF	MF	FB (DIA HOLE)	ZF+
32	64	32	47	80	10	7	130.8
40	72	36	53	90	10	9	146.5
50	90	45	65	108	12	9	156
63	100	50	75	118	12	9	171
80	126	63	95	150	16	12	190.5
100	150	75	115	176	16	14	204.5

Male Clevis

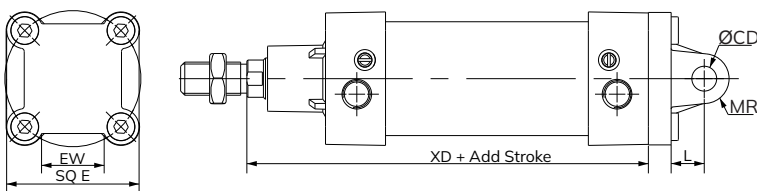

BORE DIA	SQE	ØCD	MR (MAX)	L (MIN)	EW	SQTG (CENTER DIS.)	FL	L3	ØD H11	XD+
32	45	10	10	13	20	32.5	22	5	30	142.8
40	51	12	12	16	25.4	38	25	5	35	161.5
50	64	12	12	16	30.3	46.5	27	5	40	171
63	74	16	16	21	38.4	56.5	32	5	45	191
80	93	16	16	21	40	72	36	6	45	210.5
100	110	20	20	27	70	89	41	7.5	55	229.5

Female Clevis

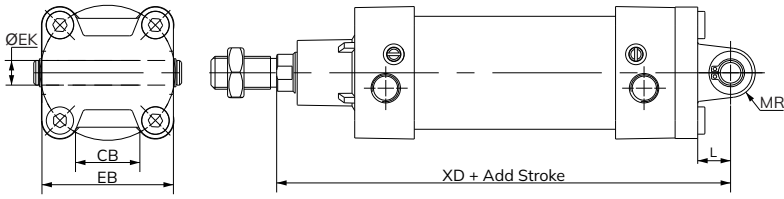

BORE DIA	ØEK	CB	EB	MR	XD+	SQE	FL	SQ TG	ØD H11	L
32	10	18.6	55	10	142.8	45	22	32.5	30	13
40	12	22.3	64	12	161.5	51	25	38	35	16
50	12	31.3	72	12	171	64	27	46.5	40	16
63	16	32	85	16	191	74	32	56.5	45	21
80	16	39	105	16	210.5	93	36	72	45	22
100	20	53.5	128	20	229.5	110	41	89	55	27

Centre Trunnion

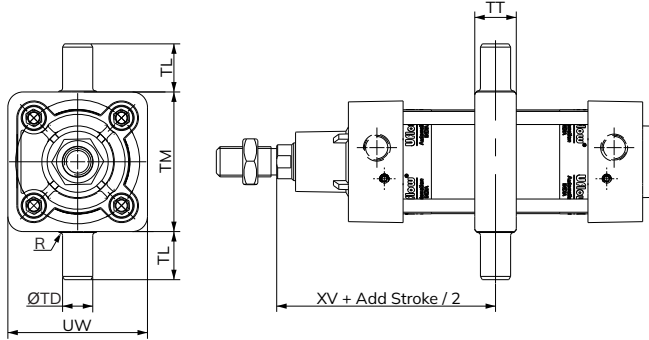

BORE DIA	TD	TL	TM	TT	R	XV +2	UW
32	12	12	50	16	1	72	48
40	16	25	62	22	1.5	84	63
50	16	25	74	22	1.6	91	74
63	20	25	88	28	1.6	97.5	90
80	20	27.5	105	28	1.6	110	105
100	25	28	125	30	2	120	129

Clevis foot bracket

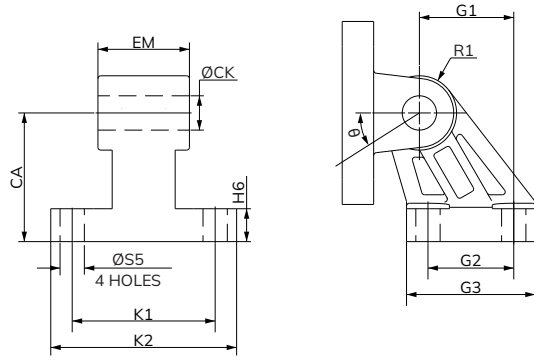

BORE DIA	ØCK	K1	G2	K2	G3	CA	ØS5	EM	R1 (MAX)	H6	θ°	Recommended Bolt Size	G1
32	10	38	18	51	31	32	6.6	26	10	8	10	M6	21
40	12	41	22	54	35	36	6.6	28	11	10	15	M6	24
50	12	50	30	65	45	45	8.5	32	13	12	15	M8	33
63	16	52	35	67	50	50	8.6	40	15	12	15	M8	37
80	16	66	40	86	60	63	10.5	50	15	14	15	M10	47
100	20	76	50	96	70	71	11	60	19	15	15	M10	55

Rod end Fork

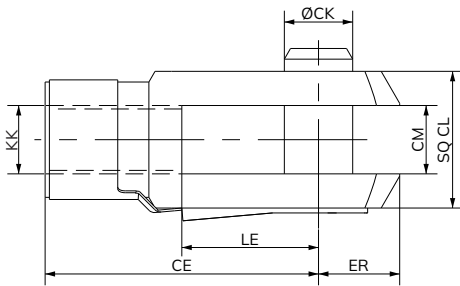

BORE DIA	KK	CE	CK (F8)	CM (B12)	LE	ER (MAX)	CL
32	M10 X 1.25	40	10	10	20	12	20
40	M12 X 1.25	48	12	12	24	14	24
50 / 63	M16 X 1.5	64	16	16	32	19	32
80 / 100	M20 X 1.5	80	20	20	40	25	40

Rod end Aligner

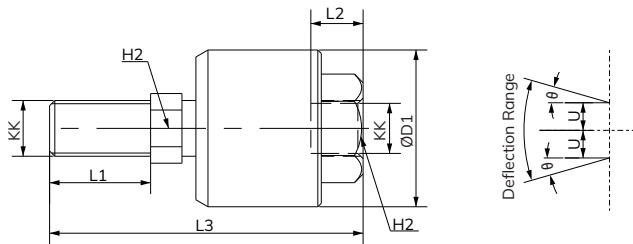

BORE DIA	KK	L1	L2	L3	H1	H2	D1	U	± θ°
32	M10 X 1.25	20	12	59	17	10	26	0.75	5
40	M12 X 1.25	22	18	65	19	12	32	1	5
50 / 63	M16 X 1.5	29	29	90	27	17	45	1	5
80 / 100	M20 X 1.5	31	28	101	32	22	51	1.5	5

Rod end Spherical eye

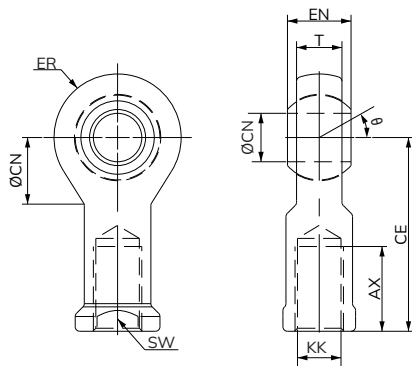

BORE DIA	KK	CN (H9)	T	EN (H12)	CE	LE (MIN)	ER (MAX)	AX	SW	Z
32	M10 X 1.25	10	10.5	14	45	15	14	20	17	13°
40	M12 X 1.25	12	12	16	50	17	16	22	19	13°
50 / 63	M16 X 1.5	16	15	21	64	22	21	28	24	13°
80 / 100	M20 X 1.5	20	18	25	77	26	25	33	30	13°

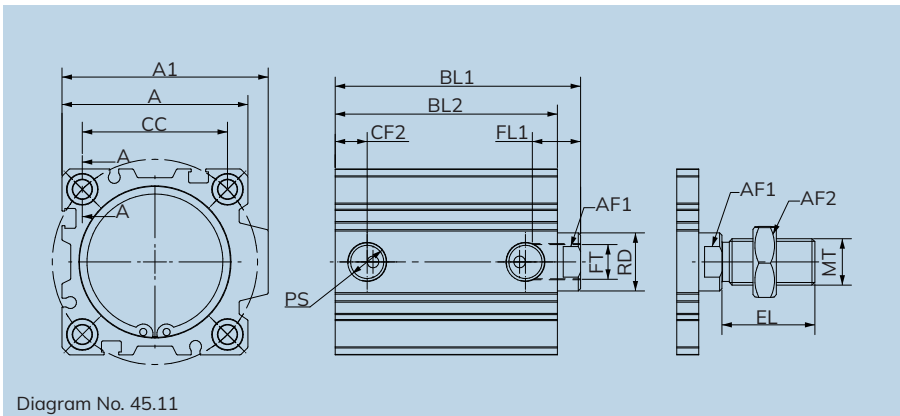

Specifications

Cylinder bore Ø (mm) :	12	16	20	25	32	40	50	63	80	100
Standard strokes (mm):	5,10,15,20,25,30,40				5,10,15,20,25,30,40,50,60			10, 20, 30, 40, 50, 60, 70, 80		
Media :	Compressed air - Filtered - Lubricated									
Working pressure :	0.5 to 10 bar									
Ambient temperature :	-10 to 60°C									
Medium temperature :	+5 to +50°C									

Features

- Small Size and Lightweight.
- High Force Output.
- Low Friction Operation.
- Short Stroke Length.

Application

- Pick-and-place Systems.
- Packaging Machines.
- Clamping Devices.
- SPMS.

Output Force

(Force in N : 1N = 0.1 kgf)

Cylinder bore Ø (mm)	Rod Dia Ø (mm)		Working Pressure In Bar								
			2	3	4	5	6	7	8	9	10
12	6	Extend	20	30	40	50	60	70	80	90	100
		Retract	15	22	30	38	46	53	61	68	76
16	8	Extend	36	854	72	90	108	126	144	162	180
		Retract	27	40	54	67	81	95	108	122	135
20	10	Extend	56	84	112	140	169	196	224	254	282
		Retract	42	63	84	106	127	148	169	190	212
25	12	Extend	88	132	176	220	264	308	352	396	440
		Retract	68	102	136	170	204	238	272	306	340
32	16	Extend	145	217	298	362	434	507	579	651	724
		Retract	108	162	217	271	325	380	434	588	542
40	16	Extend	226	339	452	565	678	792	905	1018	1130
		Retract	190	285	380	475	570	665	760	855	950
50	20	Extend	353	530	706	884	1060	1237	1414	1509	1767
		Retract	297	445	594	742	890	1039	1187	1336	1484
63	20	Extend	561	842	1122	1403	1683	1964	2244	2525	2805
		Retract	505	757	1009	1261	1514	1766	2018	2270	2523
80	25	Extend	905	1357	1809	2262	2714	3167	3619	4072	4524
		Retract	816	1225	1633	2041	2449	2857	3266	3674	4082
100	30	Extend	1414	2120	2827	3534	4241	4948	5655	6362	7068
		Retract	1287	1929	2573	3216	3859	4502	5145	5789	6432

SECTION A-A

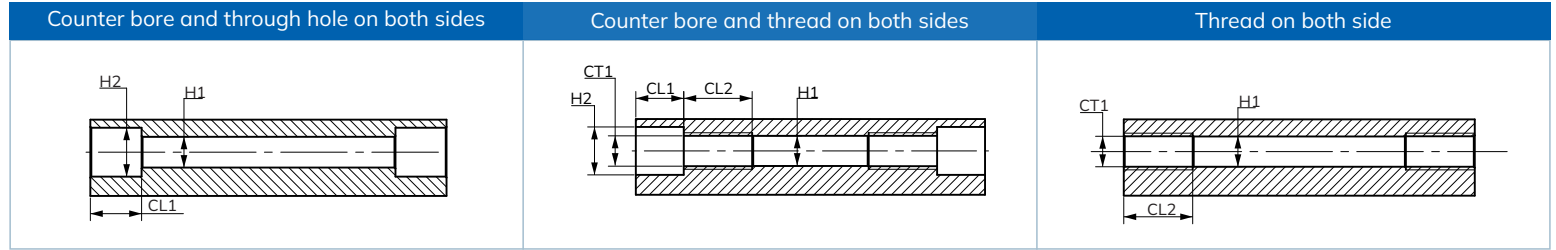

Model A - Counter bore and through hole on both side

+Add stroke

Cylinder bore Ø	FT	RD	FL1	H1	H2	CL1	AF1	CF1	CF2	PS	CC	A	A1	BL1		BL2		MT	EL	AF2
														Magnetic / Non-Magnetic	Magnetic / Non-Magnetic					
12	M3x0.5	6	8	3.5	6	5.5	5	11.5	7	M5x 0.8	15.5	25	-	33.5	29.5	37	33	M6 x1	16	10
16	M4x0.7	6	8	3.5	6	5.5	6	11	6.5		20	29	-	34.5	30.5	38	34	M8X1.25	20	13
20	M5x0.8	10	8	5.5	9	9.5	7.9	11.5	7		25.5	36	-	36.5	31.50	40	35.0	M10x 1.25	22	17
25	M6x1	12	12	5.5	9	9.5	7.9	11	5		28	40	-	38	38.0	43	43.0	M10x 1.25	22	17
32	M8x1.25	16	15	5.5	9	9.5	14	9	9	G1/8	34	45	49.5	50	45.0	57	52.0	M12x 1.25	24	19
40	M8 x1.25	16	15	5.5	9	9.5	14	10	10		40	52	57	46.5	41.5	53.5	48.5	M12x 1.25	24	19
50	M10x1.5	20	17	6.6	10.5	11	17	11	11	G1/4	50	64	71	51.5	46.5	59.5	54.5	M16 x1.5	32	24
63	M10x1.5	20	17	9	13.5	11	17	11	11		60	77	84	53.5	48.5	62.5	56.5	M16 x1.5	32	24
80	M16x2	25	21	11	16.5	14.5	22	13	13	G3/8	77	98	104	64.5	59.5	74.5	69.5	M20 x1.5	40	30
100	M20x2.5	30	27	11	16.5	14.5	27	18	18		94	117	123.5	69.5	64.5	80.5	75.5	M20 x1.5	40	30

Model B - Counter bore and thread on both sides

+Add stroke

Cylinder bore Ø	FT	RD	T3	H1	H2	CL1	AF1	CF1	CF2	PS	CC	A	A1	BL1		BL2		MT	EL	AF2	CT1	CL2
														Magnetic / Non-Magnetic	Magnetic / Non-Magnetic							
12	M3 x0.5	6	8	3.5	6	5.5	5	11.5	7	M5x 0.8	15.5	25	-	33.5	29.5	37	33	M6 x1	16	10	M4X0.7	10
16	M4 x0.7	6	8	3.5	6	5.5	6	11	6.5		20	29	-	34.5	30.5	38	34	M8X1.25	20	13	M4X0.7	10
20	M5 x0.8	10	8	5.5	9	9.5	7.9	11.5	7		25.5	36	-	36.5	31.50	40	35.0	M10x 1.25	22	17	M6X1	12
25	M6x 1	12	12	5.5	9	9.5	7.9	11	5		28	40	-	38	38.0	43	43.0	M10x 1.25	22	17	M6X1	12
32	M8 x 1.25	16	15	5.5	9	9.5	14	9	9	G1/8	34	45	49.5	50	45.0	57	52.0	M12x 1.25	24	19	M6X1	12
40	M8 x 1.25	16	15	5.5	9	9.5	14	10	10		40	52	57	46.5	41.5	53.5	48.5	M12x 1.25	24	19	M6X1	12
50	M10x1.5	20	17	6.6	10.5	11	17	11	11	G1/4	50	64	71	51.5	46.5	59.5	54.5	M16 x1.5	32	24	M8X1.25	15
63	M10x1.5	20	17	9	13.5	11	17	11	11		60	77	84	53.5	48.5	62.5	56.5	M16 x1.5	32	24	M10X1.5	18
80	M16x 2	25	21	11	16.5	14.5	22	13	13	G3/8	77	98	104	64.5	59.5	74.5	69.5	M20 x1.5	40	30	M12X1.75	22
100	M20x 2.5	30	27	11	16.5	14.5	27	18	18		94	117	123.5	69.5	64.5	80.5	75.5	M20 x1.5	40	30	M12X1.75	22

Model C – Thread on both sides

+Add stroke

Cylinder bore Ø	FT	RD	T3	H1	H2	CL1	AF1	CF1	CF2	PS	CC	A	A1	BL1		BL2		MT	EL	AF2
														Magnetic / Non-Magnetic	Magnetic / Non-Magnetic					
12	M3x0.5	6	8	3.5	6	5.5	5	11.5	7	M5x 0.8	15.5	25	-	33.5	29.5	37	33	M6 x1	16	10
16	M4x0.7	6	8	3.5	6	5.5	6	11	6.5		20	29	-	34.5	30.5	38	34	M8X1.25	20	13
20	M5x0.8	10	8	5.5	9	9.5	7.9	11.5	7		25.5	36	-	36.5	31.50	40	35.0	M10x 1.25	22	17
25	M6x1	12	12	5.5	9	9.5	7.9	11	5		28	40	-	38	38.0	43	43.0	M10x 1.25	22	17
32	M8x1.25	16	15	5.5	9	9.5	14	9	9	G1/8	34	45	49.5	50	45.0	57	52.0	M12x 1.25	24	19
40	M8 x1.25	16	15	5.5	9	9.5	14	10	10		40	52	57	46.5	41.5	53.5	48.5	M12x 1.25	24	19
50	M10x1.5	20	17	6.6	10.5	11	17	11	11	G1/4	50	64	71	51.5	46.5	59.5	54.5	M16 x1.5	32	24
63	M10x1.5	20	17	9	13.5	11	17	11	11		60	77	84	53.5	48.5	62.5	56.5	M16 x1.5	32	24
80	M16x2	25	21	11	16.5	14.5	22	13	13	G3/8	77	98	104	64.5	59.5	74.5	69.5	M20 x1.5	40	30
100	M20x2.5	30	27	11	16.5	14.5	27	18	18		94	117	123.5	69.5	64.5	80.5	75.5	M20 x1.5	40	30

CP - SERIES PNEUMATIC COMPACT CYLINDER MODEL CHART

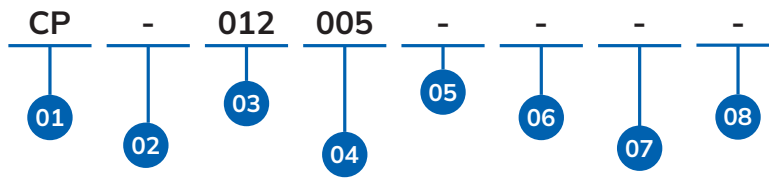

01	SERIES
CP	

02	PRODUCT TYPE
-	Compact Cylinder
M	Compact Magnetic Cylinder

03	BORE Ø (mm)
012	12
016	16
020	20
025	25
040	40
050	50
063	63
080	80
100	100

04	STROKE (mm)
005	5
010	10
015	15
020	20
...	...
100	100

05	MOUNTING TYPE
-	Counter Bore And Through Hole On Both Side
B	Thread On Both Side
C	Counter Bore And Thread On Both Side

06	OPTIONAL
-	Female Thread
M	Male Thread

07	CONFIGURATION
-	REGULAR
C1	CONFIG 1
...	...
C9	CONFIG 9
CA	CONFIG 10
CB	CONFIG 11

08	VERSION
-	VERSION 0
V1	VERSION 1
V2	VERSION 2
V3	VERSION 3
...	...
V9	VERSION 9
VA	VERSION 10
VB	VERSION 11

CP-012005
COMPACT CYLINDER BORE 12MM STROKE 5MM COUNTER BORE AND THROUGH HOLE ON BOTH SIDE

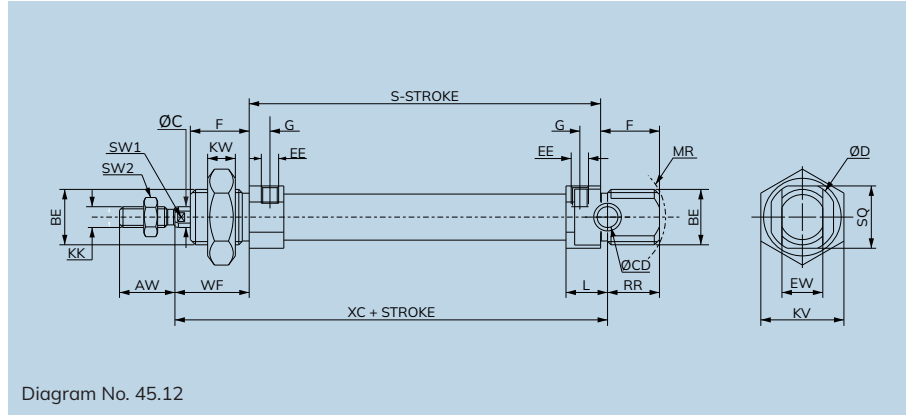

Diagram No. 45.12

Specifications

Cylinder bore Ø (mm) :	08	10	12	16	20	25
Standard strokes (mm):	10, 25, 40, 50, 80, 100		10, 25, 40, 50, 80, 100, 125,160, 200		10, 25, 40, 50, 80, 100, 125,160, 200, 250, 300	
Media :	Compressed air - filtered - lubricated					
Working pressure :	1 TO 10 bar					
Ambient temperature :	-10 to 60°C					
Medium temperature :	+5 to +50°C					
Materials of Construction :	Aluminium, Brass, Steel, Nitrile, Acetal, Polyurethane					
Mountings :	Front Foot Flange, Double foot Mounting, Front Flange, Rear Flange, Front Trunnion, Rear Trunnion					
Accessories :	Clevis Foot Bracket, Trunnion Bracket, Rod End Fork, Rod End Aligner					

Features

- Wide varieties of mountings.
- Low Friction.
- Long life.

Technical Data

All Dimension in mm

Cylinder bore Ø	MR	BE	F	CD	RR	L	G	EE	S	KW	C	SW1	SW2	KK	AW	WF (+1.5)	XC (+1)	EW	KV	SQ	D
08	12	M12 X 1.25	12	4	10	6.5	6	M5	46	6	4	7	-	M4	12	16	64	8	19	16	18
10	12	M12 X 1.25	12	4	10	6.5	6	M5	46	6	4	7	-	M4	12	16	64	8	19	16	18
12	17	M16 X 1.5	17	6	15	9.5	6	M5	51	8	6	10	5	M6 X 1	16	22	75	12	24	18	20
16	17	M16 X 1.5	17	6	15	9.5	6	M5	58	8	6	10	5	M6 X 1	16	22	82	12	24	18	20
20	20	M20 X 1.5	20	8	16	12.5	8	G1/8	67	10	8	13	7	M8 X 1.25	20	24	95	16	32	24	28
25	21	M20 X 1.5	22	8	17	12.5	8	G1/8	71	10	10	17	9	M10 X 1.25	22	28	104	16	32	28	32

Output Force

(Force in N : 1N = 0.1 kgf)

Cylinder bore Ø (mm)	Rod Ø (mm)		Working pressure in bar								
			2	3	4	5	6	7	8	9	10
08	4	Extend	9	13	18	22	27	31	36	40	45
		Retract	6	10	13	16	20	23	27	30	33
10	4	Extend	14	21	28	35	42	49	56	63	70
		Retract	11	17	23	29	35	41	47	53	59
12	6	Extend	20	30	40	50	60	70	80	90	100
		Retract	15	22	30	38	46	53	61	68	76
16	6	Extend	36	54	72	90	108	126	144	162	180
		Retract	31	46	62	78	94	108	124	140	156
20	8	Extend	56	84	112	140	169	196	224	254	282
		Retract	47	71	95	118	142	166	189	214	237
25	10	Extend	88	132	176	220	264	308	352	396	440
		Retract	74	111	148	185	222	260	296	334	371

* The values above have been determined, taking frictional loss into consideration.

MXC - SERIES MINIATURE CYLINDER ISO 6432 MODEL CHART

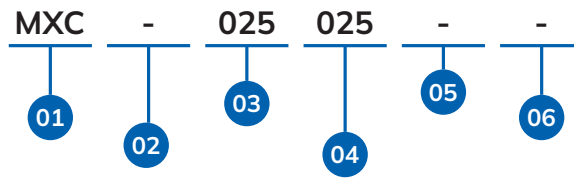

01	SERIES
	MXC

02	PRODUCT TYPE
-	Miniature Standard Cylinder
M	Miniature Magnetic Cylinder

03	BORE Ø (mm)
008	08
010	10
012	12
016	16
020	20
025	25

04	STROKE (MM)
010	10
015	15
020	20
⋮	⋮
025	25
⋮	⋮
300	300

05	CONFIGURATION
-	REGULAR
C1	CONFIG 1
C2	CONFIG 2
C3	CONFIG 3
⋮	⋮
C9	CONFIG 9
CA	CONFIG 10
CB	CONFIG 12

06	CONFIG
-	VERSION 0
V1	VERSION 1
V2	VERSION 2
V3	VERSION 3
⋮	⋮
V9	VERSION 9
VA	VERSION 10
VB	VERSION 11

MXC-025025
MINIATURE STANDARD CYLINDER OD 25-STROKE 25



AIR PREPARATION UNIT
PD SERIES

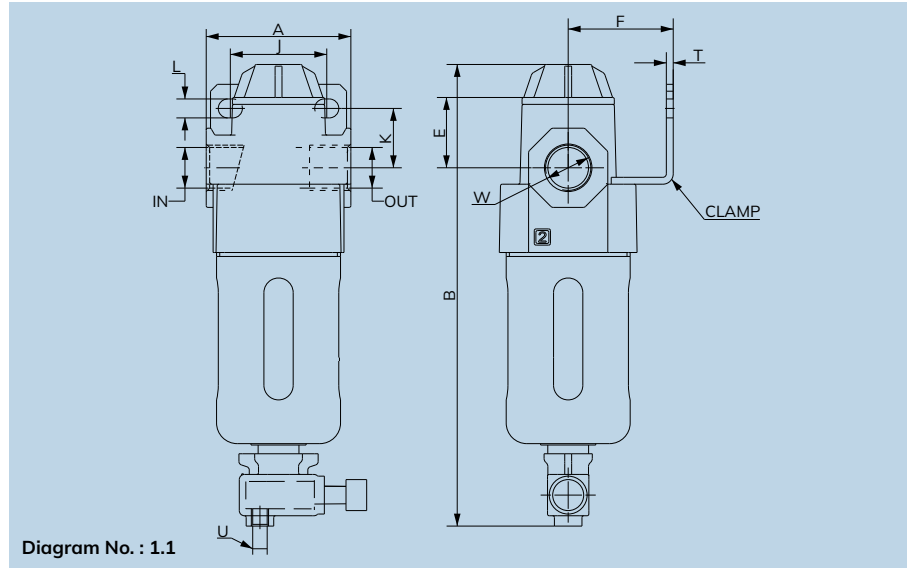

Diagram No. : 1.1

Specifications

Model No.:	PD-F1	PD-F7	PD-F2	PD-F3	PD-F4
Media :	Compressed air				
Port Size:	G¼	G¾	G½	G¾	G1
Flow Rate LPM *:	800	2250	3500	5000	6500
Maximum Supply Pressure:	10 Bar				
Ambient Temperature:	Manual Drain: -10°C to +50°C, Semi Auto Drain: +5°C to +50°C				
Media Temperature:	+5°C to +50°C				
Filtration (µm)	1, 5, 25, 40 (Standard), 50, 100				
Bowl Capacity (ml): (at maximum oil level)	9	32	44	165	165
Bowl Material:	Polycarbonate				
Installation:	Vertical (as in the picture)				
Materials of construction:	Aluminium, Bronze, Steel, Acetal, Polycarbonate, SS, Nitrile				
Optional accessories:	Clamp, Modular mounting kit				

*Supply Pressure 6 bar, pressure drop Δp = 0.5bar (For Standard Models)

Features

- Conforms to ISO 5782 -1
- Suitable for modular mounting
- Press type Manual drain for easy operation
- Bronze filtering element
- Separator and shield for efficient moisture separation

Precautions

- Note the direction of flow before installation and connect piping accordingly.
- Flush pipings for dirt, dust, rust and other foreign particles.
- Install in clean atmosphere.
- Nipples of taper threads to be used with teflon tape. Ensure teflon tape does not enter the unit during tightening.
- Nipples of straight threads to be used with sealing washer.
- Polycarbonate bowls may get damaged and possibly fail if exposed to synthetic oils, thinner, solvents, trichloroethylene, kerosene or other aromatic hydrocarbons.

Symbol

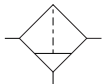

Technical Data

Model No.	Diagram No.	W	A	B	E	F	J	K	L	T	U
PD-F1	1.1	¼"	40	128	11	30	28	15	5.5	2	M5
PD-F7	1.1	¾"	55	140	14	40	40	25	6.5	2	M5
PD-F2	1.1	½"	70	170	18	50	55	25	8.5	2	M5
PD-F3	1.1	¾"	90	260	24	70	66	35	11	5	M5
PD-F4	1.1	1"	90	260	24	70	66	35	11	5	M5

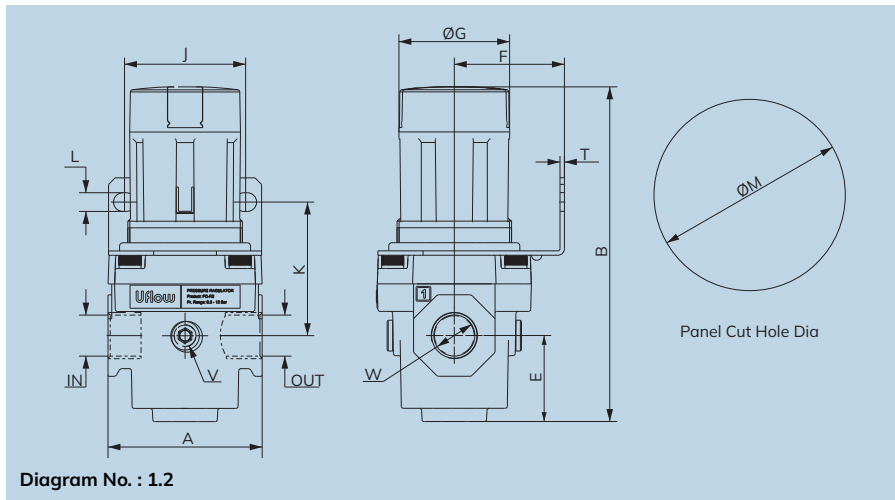

Specifications

Model No.:	PD-R1	PD-R7	PD-R2	PD-R3	PD-R4
Media :	Compressed air - Filtered				
Port Size:	G $\frac{1}{4}$	G $\frac{3}{8}$	G $\frac{1}{2}$	G $\frac{3}{4}$	G1
Pressure Gauge Port Size:	G $\frac{3}{8}$	G $\frac{1}{2}$	G $\frac{1}{8}$	G $\frac{1}{4}$	G $\frac{1}{4}$
Flow Rate LPM*:	600	2500	4000	5000	6000
Maximum Supply Pressure:	15 Bar				
Regulating Pressure Range:	0.2- 2, 0.2 -4, 0.5-7, 0.5-12				
Media Temperature:	+5°C to +50°C				
Ambient Temperature:	-10°C to +60°C				
Installation:	Any Position				
Materials of construction:	Aluminium, Brass, Steel, Acetal, SS, Nitrile				
Optional accessories:	Clamp, Modular mounting kit, Pressure Gauge				

*Supply Pressure 7 bar, pressure drop $\Delta p = 0.5\text{bar}$ (For Standard Models)

Features

- Conforms to ISO 6953 - 1
- Suitable for panel and modular mountings
- Nonraising 'Push To Lock' Adjusting Knob For Locking At Any Set Pressure
- Diaphragm operated, relieving type
- Pressure Compensated By Balanced Poppet
- Good Flow And Regulating Characteristics

Precautions

- Note the direction of flow before installation and connect piping accordingly.
- Flush pipings for dirt, dust, rust and other foreign particles.
- Install in clean atmosphere.
- Nipples of taper threads to be used with teflon tape. Ensure teflon tape does not enter the unit during tightening. Nipples of straight threads to be used with sealing washer.

Symbol

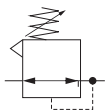

Pressure Setting

Pull the knob and adjust by turning the knob clockwise to increase the pressure. Push the knob back to its locked position. (Turning the knob counter clockwise will reduce the pressure)

Technical Data

Model No.	Diagram No.	W	V	A	B	E	F	ØG	J	K	L	T	ØM
PD-R1	1.2	¼"	⅛"	40	81	13	30	25	28	45	5.5	2	30.5
PD-R7	1.2	⅜"	⅛"	55	135	40	40	40	40	53	6.5	2	43
PD-R2	1.2	½"	⅛"	70	164	40	50	47	55	62	8.5	2	53
PD-R3	1.2	¾"	¼"	90	177	48	70	51	66	65	11	5	53
PD-R4	1.2	1"	¼"	90	177	48	70	51	66	65	11	5	53

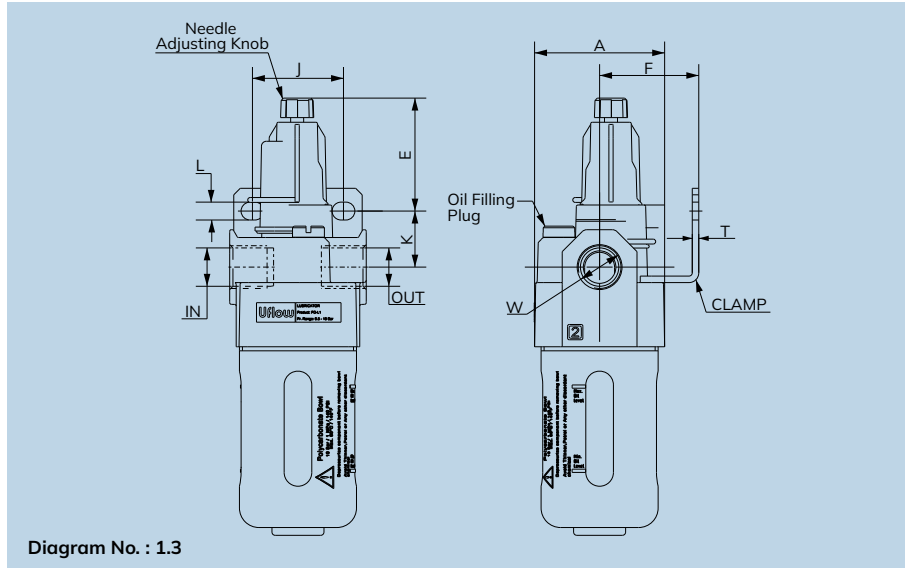

Specifications

Model No.:	PD-L1	PD-L7	PD-L2	PD-L3	PD-L4
Media :	Compressed air - Filtered				
Port Size:	G¼	G¾	G½	G¾	G1
Flow Rate LPM*:	1350	3000	5650	7200	9000
Maximum Supply Pressure:	10 Bar				
Ambient Temperature:	-10°C to +50°C				
Medium Temperature:	+5°C to +50°C				
Min Operating Flow (lts/min):	12	40	45	50	50
Bowl Capacity (ml): (at maximum oil level)	20	57	152	200	200
Recommended Oil:	ISO VG 32 (Servo System 32)				
Bowl Material:	Polycarbonate				
Installation:	Vertical (as in the picture)				
Materials of construction:	Aluminium, Bronze, Steel, Acetal, Polycarbonate, SS, Nitrile				
Optional accessories:	Clamp, Modular mounting kit				

*Supply Pressure 6 bar, pressure drop Δp = 0.5bar (For Standard Models)

Features

- Conforms to ISO 6301-1
- Suitable for modular mounting
- Fog/Mist type
- Fine adjustment of lubrication
- Lubrication proportional to flow

Symbol

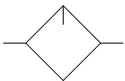

Precautions

- Note the direction of flow before installation and connect piping accordingly.
- Flush pipings for dirt, dust, rust and other foreign particles.
- Install in clean atmosphere.
- Nipples of taper threads to be used with teflon tape. Ensure teflon tape does not enter the unit during tightening. Nipples of straight threads to be used with sealing washer.
- Polycarbonate bowls may get damaged and possibly fail if exposed to synthetic oils, thinner, solvents, trichloroethylene, kerosene or other aromatic hydrocarbons.
- Oil may be filled when under pressure. However it is recommended to vent the air completely before filling the oil.

Technical Data

Model No.	Diagram No.	W	A	B	E	F	J	K	L	T
PD-L1	1.3	¼"	40	124	42	30	28	15	5.5	2
PD-L7	1.3	¾"	55	150	44	40	40	25	6.5	2
PD-L2	1.3	½"	70	181	46	50	55	15	8.5	2
PD-L3	1.3	¾"	90	267	47	70	66	35	11	5
PD-L4	1.3	1"	90	267	47	70	66	35	11	5

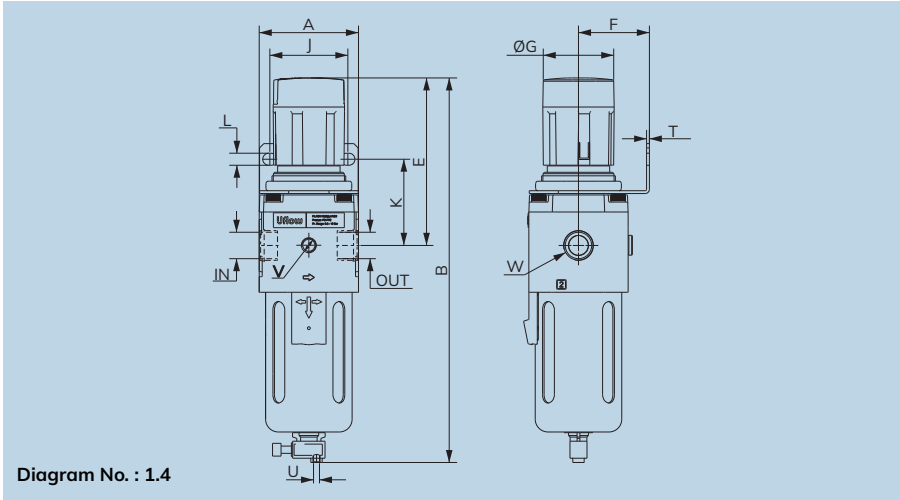

Diagram No. : 1.4

Specifications

Model No.:	PD-FR1	PD-FR7	PD-FR2	PD-FR3	PD-FR4
Media :	Compressed Air				
Port Size:	G¼	G¾	G½	G¾	G1
Pressure Gauge Port Size:	G¾	G¾	G¾	G¼	G¼
Flow Rate LPM*:	500	1800	3000	4250	5500
Maximum Supply Pressure:	10 Bar				
Regulating Pressure Range:	0.2- 2, 0.2- 4, 0.5- 7, 0.5- 10 (Standard)				
Medium Temperature:	+5°C to +50°C				
Filteration (µm)	1, 5, 25, 40 (Standard), 50, 100				
Bowl Capacity (ml) (at maximum condensate level)	9	32	44	165	165
Bowl Material	Polycarbonate				
Installation:	Vertical				
Materials of construction:	Aluminium, Brass, Steel, Acetal, SS, Nitrile				
Optional accessories:	Clamp, Modular mounting kit, Pressure Gauge				

*Supply Pressure 7 bar, pressure drop Δp = 0.5bar (For Standard Models)

Features

- Modular type
- Suitable for panel mounting
- Filter
 - Bronze filtering element
 - Separator and shield for efficient moisture separation
- Regulator
 - Diaphragm operated, relieving type
 - Pressure compensated by balanced poppet
 - Non raising 'Press to lock' adjusting knob for locking at any set pressure
- Good flow and regulating characteristics

Precautions

- Note the direction of flow before installation and connect piping accordingly.
- Flush pipings for dirt, dust, rust and other foreign particles.
- Install in clean atmosphere.
- Nipples of taper threads to be used with teflon tape. Ensure teflon tape does not enter the unit during tightening. Nipples of straight threads to be used with sealing washer.
- Polycarbonate bowls may get damaged and possibly fail if exposed to synthetic oils, thinner, solvents, trichloroethylene kerosene or other aromatic hydrocarbons.

Pressure Setting

Pull the knob and adjust by turning the knob clockwise to increase the pressure. Push the knob back to its locked position. (Turning the knob counter clockwise will reduce the pressure)

Symbol

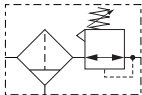

Technical Data

Model No.	Diagram No.	W	V	A	B	E	F	ØG	J	K	L	T	U
PD-FR1	1.4	¼"	⅛"	40	165	64	30	25	28	45	5.5	2	M5
PD-FR7	1.4	⅜"	⅛"	55	220	95	40	40	40	53	6.5	2	M5
PD-FR2	1.4	½"	⅛"	70	287	134	50	47	55	62	8.5	2	M5
PD-FR3	1.4	¾"	¼"	90	370	130	70	51	66	65	11	5	M5
PD-FR4	1.4	1"	¼"	90	370	130	70	51	66	65	11	5	M5

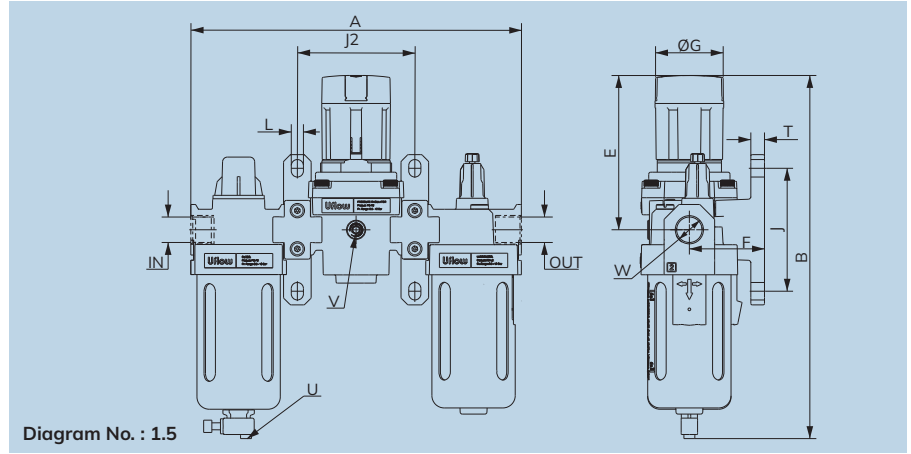

Diagram No. : 1.5

Specifications

Model No.:	PD-F1:R1:L1:MK1	PD-F7:R7:L7:MK7	PD-F2:R2:L2:MK2	PD-F3:R3:L3:MK3	PD-F4:R4:L4:MK4
Media :	Compressed Air				
Port Size:	G $\frac{1}{4}$	G $\frac{3}{8}$	G $\frac{1}{2}$	G $\frac{3}{4}$	G1
Pressure Gauge Port Size:	G $\frac{1}{8}$	G $\frac{1}{8}$	G $\frac{1}{8}$	G $\frac{1}{4}$	G $\frac{1}{4}$
Flow Rate LPM*:	500	1250	2800	3500	4000
Maximum Supply Pressure:	10 Bar				
Regulating Pressure Range:	0.2 - 2, 0.2 - 4, 0.5 - 7, 0.5- 10 (Standard)				
Ambient Temperature:	-10°C to +50°C				
Medium Temperature:	+5°C to +50°C				
Filteration (μ m)	1, 5, 25, 40 (Standard), 50, 100				
Min Operating Flow (lts / min)	12	40	45	50	50
Bowl Capacity FRC (ml) (at maximum condensate level)	9	32	44	165	165
Bowl Capacity Lubricator (ml) (at maximum oil level)	20	57	152	200	200
Recommended Oil	ISO VG 32 (Servo System 32)				
Bowl Material	Polycarbonate				
Installation:	Vertical				
Materials of construction:	Aluminium, Brass, Steel, Acetal, SS, Nitrile				
Optional accessories:	Clamp, Modular mounting kit, Pressure Gauge				

*Supply Pressure 7 bar, pressure drop $\Delta p = 0.5$ bar (For Standard Models)

Features

- Modular type for easy and fast maintenance
- Suitable for wall mounting
- Filter
 - Bronze filtering element
 - Separator and shield for efficient moisture separation
 - Press type manual drain for easy operation
- Regulator
 - Diaphragm operated, relieving type
 - Pressure compensated by balanced poppet
 - Non raising 'Press to lock' adjusting knob for locking at any set pressure
- Lubricator
 - Fog / Mist type Lubricator
 - Fine adjustment of lubrication
 - Lubrication proportional to flow
- Good flow and regulating characteristics

Precautions

- Note the direction of flow before installation and connect piping accordingly.
- Flush pipings for dirt, dust, rust and other foreign particles.
- Install in clean atmosphere.
- Nipples of taper threads (R) to be used with teflon tape. Ensure teflon tape does not enter the unit during tightening. Nipples of straight threads (G) to be used with sealing washer.
- Polycarbonate bowls may get damaged and possibly fail if exposed to synthetic oils, thinner, solvents, trichloroethylene, kerosene or other aromatic hydrocarbons.

Pressure Setting

Pull the knob and adjust by turning the knob clockwise to increase the pressure. Push the knob back to its locked position. (Turning the knob counter clockwise will reduce the pressure)

Symbol

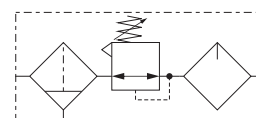

Technical Data

Model No.	Diagram No.	W	V	A	B	E	F	ØG	J	J2	L	T	U
PD-F1:R1:L1:MK1	1.5	¼"	⅙"	145	170	68	34	25	50	52	7	7	M5
PD-F7:R7:L7:MK7	1.5	⅜"	⅙"	192	220	95	45	40	70	69	7	7	M5
PD-F2:R2:L2:MK2	1.5	½"	⅙"	242	275	124	53	47	90	86	9	9	M5
PD-F3:R3:L3:MK3	1.5	¾"	¼"	300	366	130	70	51	100	105	12	10	M5
PD-F4:R4:L4:MK4	1.5	1"	¼"	300	366	130	70	51	100	105	12	10	M5

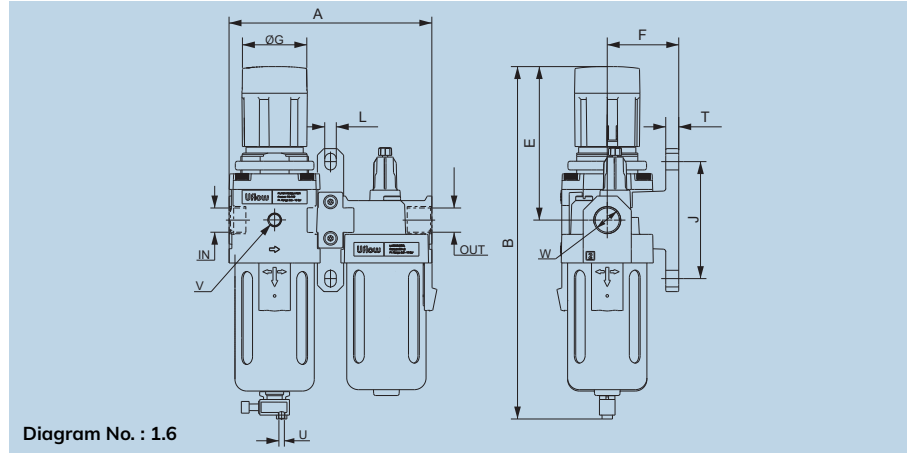

Diagram No. : 1.6

Specifications

Model No.:	PD-FR1:L1:MK1	PD-FR7:L7MK7	PD-FR2:L2:MK2	PD-FR3:L3:MK3	PD-FR4:L4:MK4
Media :	Compressed Air				
Port Size:	G $\frac{1}{4}$	G $\frac{3}{8}$	G $\frac{1}{2}$	G $\frac{3}{4}$	G1
Pressure Gauge Port Size:	G $\frac{1}{8}$	G $\frac{1}{8}$	G $\frac{1}{8}$	G $\frac{1}{4}$	G $\frac{1}{4}$
Flow Rate LPM*:	500	1250	2800	3500	4000
Maximum Supply Pressure:	10 Bar				
Regulating Pressure Range:	0.2- 2, 0.2- 4, 0.5- 7, 0.5- 10 (Standard)				
Ambient Temperature:	-10°C to +50°C				
Medium Temperature:	+5°C to +50°C				
Filteration (μ m)	1, 5, 25, 40 (Standard), 50, 100				
Min Operating Flow (lts / min)	12	40	45	50	50
Bowl Capacity FRC (ml) (at maximum condensate level)	9	32	44	165	165
Bowl Capacity Lubricator (ml) (at maximum oil level)	20	57	152	200	200
Recommended Oil	ISO VG 32 (Servo System 32)				
Bowl Material	Polycarbonate				
Installation:	Vertical				
Materials of construction:	Aluminium, Brass, Steel, Acetal, SS, Nitrile				
Optional accessories:	Clamp, Modular mounting kit, Pressure Gauge				

*Supply Pressure 7 bar, pressure drop $\Delta p = 0.5\text{bar}$ (For Standard Models)

Features

- Modular type for easy and fast maintenance
- Suitable for wall mounting
- Filter
 - Bronze filtering element
 - Separator and shield for efficient moisture separation
 - Press type manual drain for easy operation
- Regulator
 - Diaphragm operated, relieving type
 - Pressure compensated by balanced poppet
 - Non raising 'Press to lock' adjusting knob for locking at any set pressure
- Lubricator
 - Fog / Mist type Lubricator
 - Fine adjustment of lubrication
 - Lubrication proportional to flow
- Good flow and regulating characteristics

Precautions

- Note the direction of flow before installation and connect piping accordingly.
- Flush pipings for dirt, dust, rust and other foreign particles.
- Install in clean atmosphere.
- Nipples of taper threads (R) to be used with teflon tape. Ensure teflon tape does not enter the unit during tightening. Nipples of straight threads (G) to be used with sealing washer.
- Polycarbonate bowls may get damaged and possibly fail if exposed to synthetic oils, thinner, solvents, trichloroethylene, kerosene or other aromatic hydrocarbons.

Pressure Setting

Pull the knob and adjust by turning the knob clockwise to increase the pressure. Push the knob back to its locked position. (Turning the knob counter clockwise will reduce the pressure)

Symbol

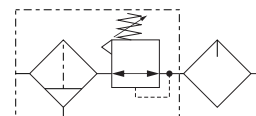

Technical Data

Model No.	Diagram No.	W	V	A	B	E	F	ØG	J	L	T	U
PD-FR1:L1:MK1	1.6	¼"	⅛"	92	170	69	34	25	50	7	7	M5
PD-FR7:L7:MK7	1.6	⅜"	⅛"	124	220	95	45	40	70	7	7	M5
PD-FR2:L2:MK2	1.6	½"	⅛"	155	276	123	53	47	90	9	9	M5
PD-FR3:L3:MK3	1.6	¾"	¼"	200	370	130	70	51	100	12	10	M5
PD-FR4:L4:MK4	1.6	1"	¼"	200	370	130	70	51	100	12	10	M5

PD -SERIES AIR FILTER MODEL CHART

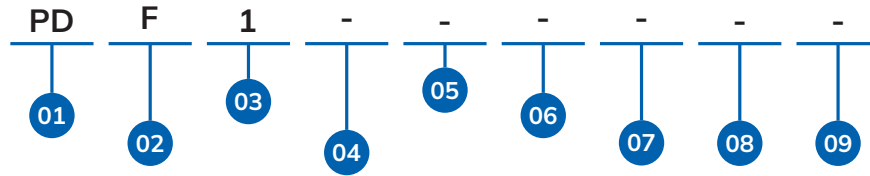

01	SERIES
-	PD

02	PRODUCT TYPE
F	Filter

03	PORT SIZE
1	1/4"
2	1/2"
3	3/4"
4	1"
7	3/8"

04	PORT CONNECTION
-	BSP
N	NPT

04	PRESSURE RANGE
-	0.5 - 10 Bar
B	0.5 - 20 Bar (Only For Metal Bowl)
C	2 TO 10 Bar (only For Internal Auto Drain)

05	FILTRATION IN μm
-	40 μm (Standard)
1	1 μm Filtration
2	5 μm Filtration
3	15 μm Filtration
4	25 μm Filtration
5	50 μm Filtration
6	100 μm Filtration
7	0.01 μm (Mist Separator)
8	0.1 μm (Mist Separator)

06	BOWL MATERIAL
-	PC Bowl
M	Metal Bowl
L	Metal Bowl With Level Indicator

07	FEATURES
-	Manual Drain
A	Internal Auto Drain

08	CONFIGURATION
-	REGULAR
C1	CONFIG 1
C2	CONFIG 2
C3	CONFIG 3
...	...
C9	CONFIG 9
CA	CONFIG 10
CB	CONFIG 11

09	VERSION
-	VERSION 0
V1	VERSION 1
V2	VERSION 2
V3	VERSION 3
...	...
V9	VERSION 9
VA	VERSION 10
VB	VERSION 11

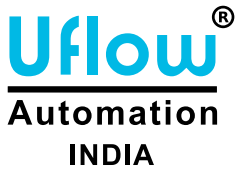

PD-F1
1/4" FILTER 40 μm (STANDARD) ALUMINUM-0.5 TO 10 BAR-
BSP-PC BOWL-MANUAL DRAIN

PD - SERIES AIR REGULATOR MODEL CHART

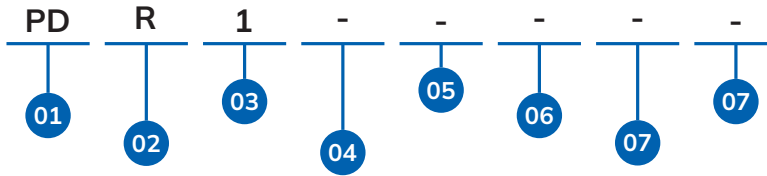

01	SERIES
	PD

02	PRODUCT TYPE
R	Regulator

03	PORT SIZE
1	1/4"
2	1/2"
3	3/4"
4	1"
7	3/8"

04	PORT CONNECTION
-	BSP
N	NPT

05	PRESSURE RANGE
-	0.5 - 12 Bar

06	FEATURES
-	REGULAR
W	With NRV

07	CONFIGURATION
-	REGULAR
C1	CONFIG 1
C2	CONFIG 2
C3	CONFIG 3
⋮	⋮
C9	CONFIG 9
CA	CONFIG 10
CB	CONFIG 11

08	VERSION
-	VERSION 0
V1	VERSION 1
V2	VERSION 2
V3	VERSION 3
⋮	⋮
V9	VERSION 9
VA	VERSION 10
VB	VERSION 11

PD-R1
1/4" REGULATOR ALUMINUM-0.5 TO 12 BAR-BSP

PD -SERIES AIR LUBRICATOR MODEL CHART

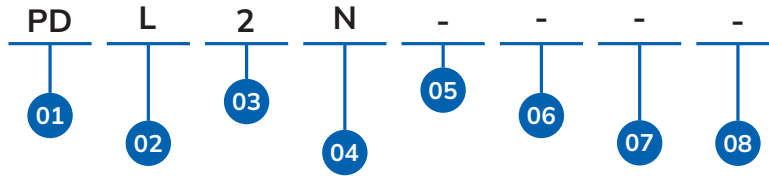

01	SERIES
	PD

02	PRODUCT TYPE
L	Lubricator

03	PORT SIZE
1	1/4"
2	1/2"
3	3/4"
4	1"
7	3/8"

04	PORT CONNECTION
-	BSP
N	NPT

06	PRESSURE RANGE
-	0.5 - 10 Bar
B	0.5 - 20 Bar (Only For Metal Bowl)

05	BOWL MATERIAL
-	PC Bowl
M	Metal Bowl
L	Metal Bowl With Level Indicator

07	CONFIGURATION
-	REGULAR
C1	CONFIG 1
C2	CONFIG 2
C3	CONFIG 3
⋮	⋮
C9	CONFIG 9
CA	CONFIG 10
CB	CONFIG 11

08	VERSION
-	VERSION 0
V1	VERSION 1
V2	VERSION 2
V3	VERSION 3
⋮	⋮
V9	VERSION 9
VA	VERSION 10
VB	VERSION 11

PD-L2N
1/2" LUBRICATOR ALUMINUM-0.5 TO 10 BAR-NPT-PC BOWL

PD -SERIES AIR FILTER REGULATOR COMBO MODEL CHART

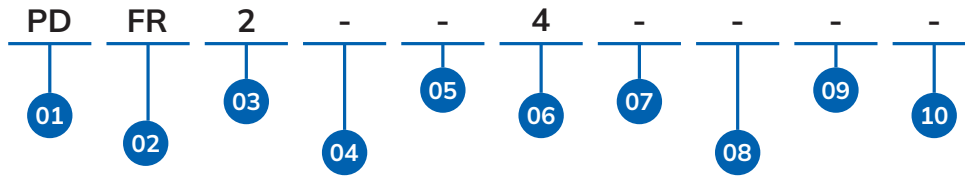

01	SERIES
	PD

02	PRODUCT TYPE
FR	Filter Regulator Combo

03	PORT SIZE
1	1/4"
2	1/2"
3	3/4"
4	1"
7	3/8"

04	PORT CONNECTION
-	BSP
N	NPT

05	PRESSURE RANGE
-	0.5 - 10 Bar
B	0.5 - 20 Bar (Only For Metal Bowl)
C	2 TO 10 BAR (Only For Internal Auto Drain)

06	FILTRATION IN μm
-	40 μm (Standard)
1	1 μm Filtration
2	5 μm Filtration
3	15 μm Filtration
4	25 μm Filtration
5	50 μm Filtration
6	100 μm Filtration
7	0.01 μm (Mist Separator)
8	0.1 μm (Mist Separator)

07	BOWL MATERIAL
-	PC Bowl
M	Metal Bowl
L	Metal Bowl With Level Indicator

08	FEATURES
-	Manual Drain
A	Internal Auto Drain

09	CONFIGURATION
-	REGULAR
C1	CONFIG 1
C2	CONFIG 2
C3	CONFIG 3
⋮	⋮
C9	CONFIG 9
CA	CONFIG 10
CB	CONFIG 11

10	VERSION
-	VERSION 0
V1	VERSION 1
V2	VERSION 2
V3	VERSION 3
⋮	⋮
V9	VERSION 9
VA	VERSION 10
VB	VERSION 11

PD-FR24
1/2" FILTER REGULATOR COMBO 25 μm ALUMINIUM-0.5 TO 10 BAR-BSP-PC BOWL-MANUAL DRAIN



Valve Specifications

Model No.	PB-2	PB-R2	PB-W2
Type :	Piston Type, Self Relieving		
Body :	CF8	BRASS BAR	WCB
Port Size :	½" BSP Female		
Orifice :	12mm		
Seals :	Nitrile (NBR)		
Media :	Compressed Air (Filtered & Lubricated)		
Temperature :	+5°C to +50°C		
Pressure Range :	Inlet - 3 to 42 bar, Regulated 0 to 42 bar		
Flow (NLPM) at 5 Bar :	2500 Normal litres per min.		

Dimension Drawing (All dimensions in mm)

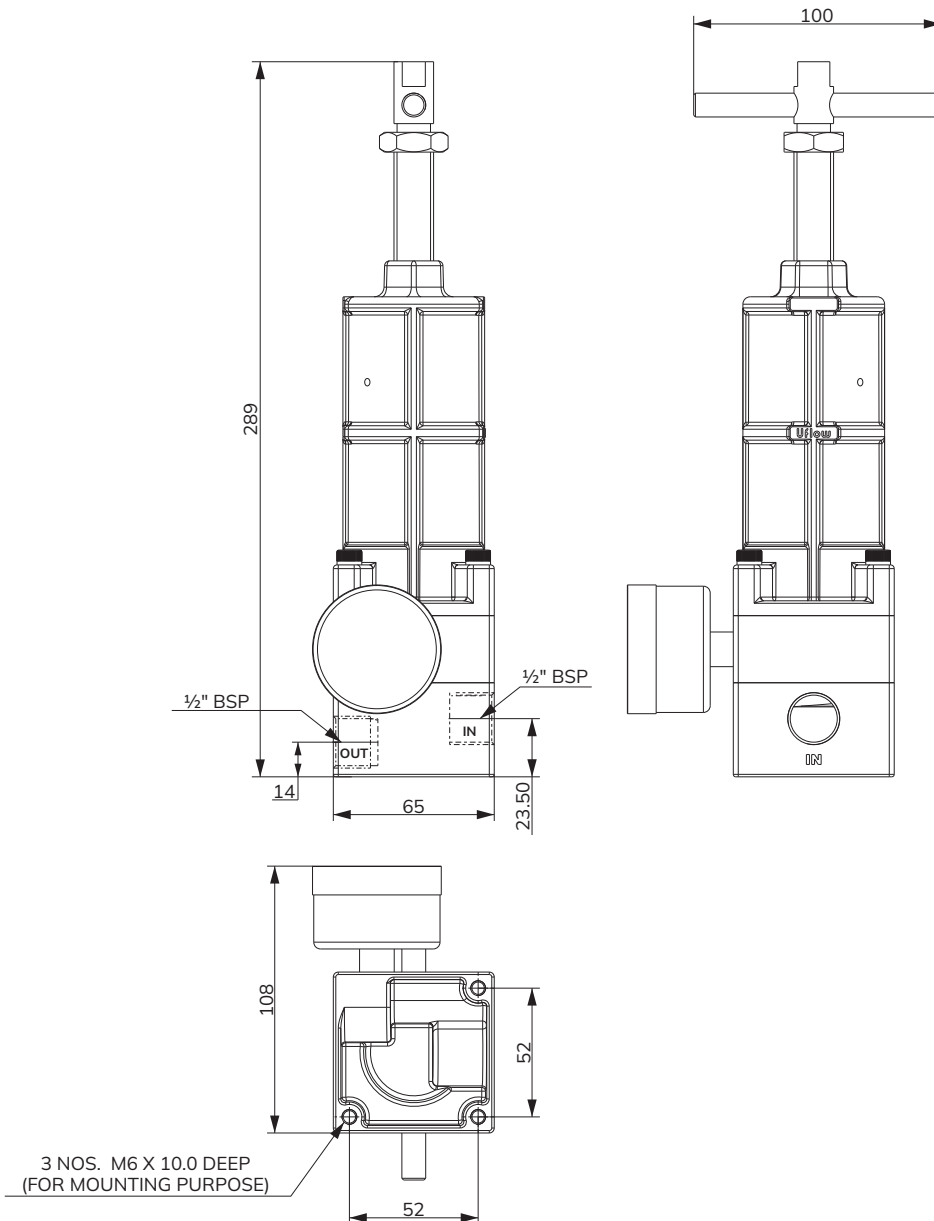

PB - SERIES HIGH PRESSURE REGULATOR PISTON TYPE MODEL CHART

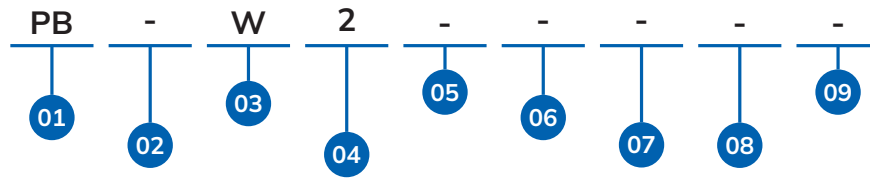

01	SERIES
PB	

02	PRODUCT TYPE
-	Regulator Piston Type

03	Body Material
-	CF8
B	Brass Forge
W	WCB
R	Brass Bar

04	PORT SIZE & CONNECTION
2	1/2" BSP

05	INPUT PRESSURE
-	3 TO 42 BAR

06	OUTPUT PRESSURE
-	0 TO 42 BAR

07	FEATURES
-	Regular

08	CONFIGURATION
-	REGULAR
C1	CONFIG 1
C2	CONFIG 2
C3	CONFIG 3
⋮	⋮
C9	CONFIG 9
CA	CONFIG 10
CB	CONFIG 11

09	VERSION
-	VERSION 0
V1	VERSION 1
V2	VERSION 2
V3	VERSION 3
⋮	⋮
V9	VERSION 9
VA	VERSION 10
VB	VERSION 11

PB-W2
1/2" BSP REGULATOR PISTON TYPE WCB-I/P 3 TO 42 BAR-
O/P 0 TO 42 BAR-REGULAR



PRV Specifications

Type :	Diaphragm Operated
Body :	Brass, SS316L
Port Size :	¼" - NPT Female
Media :	Nitrogen, O ₂ , Argon, etc...
Circumstance Temp :	-40°C to +110°C
Inlet Pressure:	400 Bar
Regulated Pressure:	0 to 25 Bar
Nominal Flow at 20 Bar Outlet Pressure :	40 m ³ /hr
Safety Valve Cracking Pressure :	30 Bar (Adjustable)

Features

- ✔ A filter has been added to the inlet port and an inlet pressure gauge has been installed in accordance with standard 6901.
- ✔ Metal diaphragm maintain consistent pressure regulation, offering precise control over system pressures.
- ✔ Very compact design.
- ✔ Bottom mounting available.
- ✔ Adjustable relief pressure.

Flow Chart

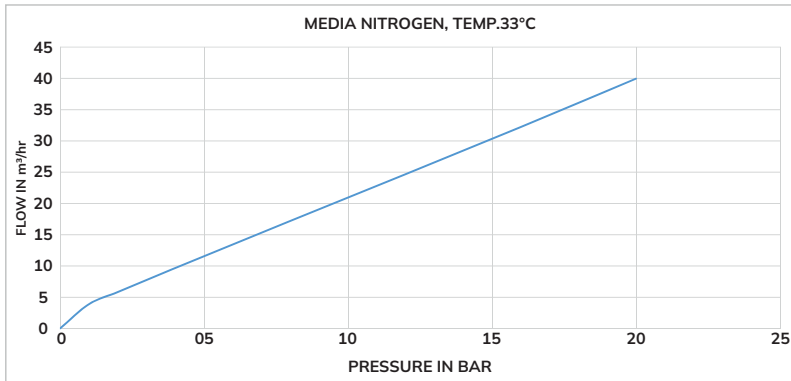

Dimension Drawing (All dimension in mm)

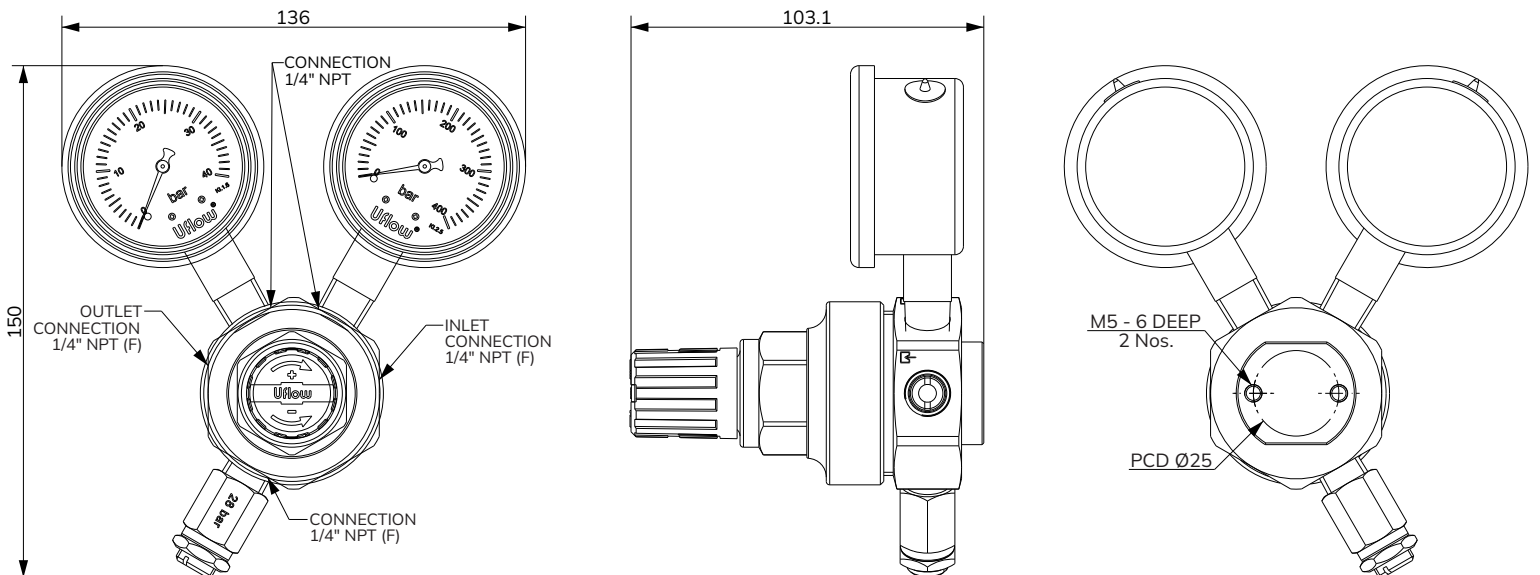

* All dimensions are approx

DR - SERIES HIGH PRESSURE DIAPHRAGM TYPE REGULATOR MODEL IDENTIFICATION CHART

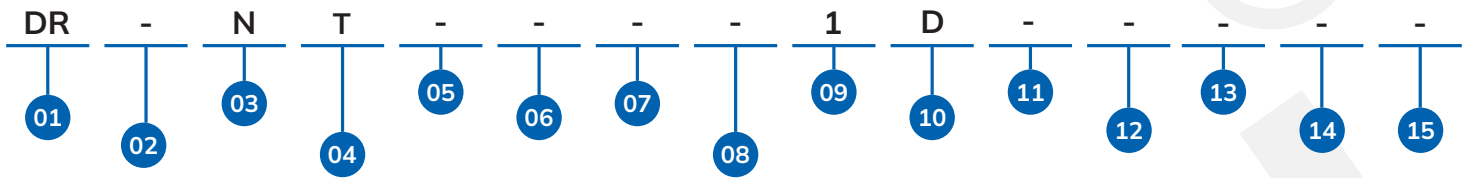

01	SERIES
-	DR

02	PRODUCT TYPE
-	Diaphragm Type Regulator

03	INPUT PRESSURE
M	200 BAR
N	400 BAR

04	OUTPUT PRESSURE
S	0 TO 30 BAR
T	0 TO 25 BAR

05	PORT SIZE
-	1/4" NPT (F)

06	BODY MATERIAL
-	SS 316L
B	Brass
A	Aluminium (only For 200 Bar)

07	SEAL MATERIAL
-	Engineering Plastic

08	PORTING
-	5 Ports

09	INLET GAUGE
-	W/O Gauge
1	0 To 400 Bar Brass
2	0 To 250 Bar Brass Wika
3	0 To 250 Bar SS Baumer
4	0 To 600 Bar Brass Wika Dry
5	0 To 250 Bar Brass Wika Dry

10	OUTLET GAUGE
-	W/O GAUGE
C	0 To 70 Bar Brass
D	0 To 40 Bar Brass Wika
E	0 To 40 Bar SS Baumer
F	0 To 40 Bar Brass Wika Dry

11	CYLINDER INLET CONNECTION
-	W/O I/C
X	5/8" (M)
Y	3/4" (F)

12	PROCESS OUTLET CONNECTION
-	W/O I/C
M	1/2" BSP (M)

13	FEATURES
-	Relief Valve
W	W/O Relief Valve

14	CONFIGURATION
-	REGULAR
C1	CONFIG 1
C2	CONFIG 2
C3	CONFIG 3
...	...
C9	CONFIG 9
CA	CONFIG 10
CB	CONFIG 11

15	VERSION
-	VERSION 0
V1	VERSION 1
V2	VERSION 2
V3	VERSION 3
...	...
V9	VERSION 9
VA	VERSION 10
VB	VERSION 11

DR-NT1D
1/4" NPT (F) DIAPHRAGM TYPE REGULATOR SS316L-I/P 400 BAR-0 TO 400 BAR BRASS GAUGE-O/P 0 TO 25 BAR-0 TO 40 BAR BRASS GAUGE WIKA- ENGINEERING PLASTIC-5 PORTS-RELIEF VALVE



ONE TOUCH FITTINGS
SERIES

Specifications

Media :	Air
Max. operating pressure :	10 Bar
Ambient temperature :	-10°C to +60°C
Threaded connection :	Male : R - Taper thread, Female : G - Parallel thread
Media temperature :	+5°C to +50°C
Applicable tube material :	Nylon, Polyurethane
Applicable tube size (OD) :	Ø4, Ø6, Ø8, Ø10, Ø12, Ø14, Ø16
Recommended tolerance for tube OD :	±0.1 mm
Recommended minimum wall thickness of tubes :	

Nylon		PU	
Tube OD (mm)	Thickness (mm)	Tube OD (mm)	Thickness (mm)
Ø4	1	Ø4	1
Ø6		Ø6	1
Ø8		Ø8	1.5
Ø10		Ø10	1.5
Ø12		Ø12	2
Ø14		Ø14	2
Ø16		Ø16	2.5

Features

- ✓ Compact & Captivating Design
- ✓ All Threaded nipples has plastic portion that is capable of rotating 360°
- ✓ Full bore piping enables smooth flow of fluids.
- ✓ New Design SS collet
- ✓ Air tight sealing of tubes
- ✓ Compatible with both Nylon & PU pipes
- ✓ Male Taper threads with PTFE coating
- ✓ Durable & Maintenance free
- ✓ Robust collet design lets the fitment & function remains unaffected even due to vibration.
- ✓ Simple & fast connection of tube just by plugging-in manually and similarly smooth way of pulling-out just by the press of plastic collet cap.

Application

One-touch fitting can be effectively used in all compressed air applications. Some of the pneumatic application include

- ✓ Pneumatic cylinders (all types)
- ✓ All compressed air lines, machinery of all kinds wherever pneumatic systems are used
- ✓ Directional control valves(DCV), solenoid valves(SOV) and other valves
- ✓ Pneumatic control & circuit panels
- ✓ Air preparation units like filter, regulator and lubricators(FRL)

Straight Union

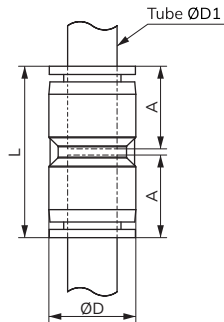

Model No.	Tube OD - ØD1	ØD	L	A
VO-210404	4	11	31	12
VO-210606	6	13	33	15
VO-210808	8	15	35	16
VO-211010	10	19	39	18
VO-211212	12	21	42	20
VO-211414	14	23	42	20
VO-211616	16	26	46	22

Different Dia. Straight Union

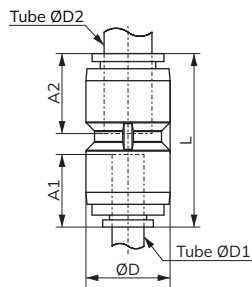

Model No.	Tube OD		ØD	L	A1	A2
	ØD1	ØD2				
VO-220406V1	4	6	13	35	16	15
VO-220608V1	6	8	15	37	16	16
VO-220610	6	10	19	41	17	18
VO-220810V1	8	10	19	41	18	18
VO-220812	8	12	21	44	18	20
VO-221012V1	10	12	31	44	20	20
VO-221216	12	16	26	48	22	22

Union Elbow Reducer

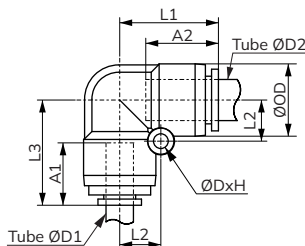

Model No.	Tube OD		ØD	L1	L2	L3	A1	A2	ØDxH
	ØD1	ØD2							
VO-240812	8	12	21	31	12	29	18	21	Ø4.3X21.5

Union Elbow

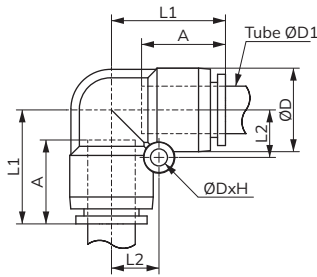

Model No.	Tube OD ØD1	ØD	L1	L2	A	ØDXH
VO-230404	4	11	18	7	15	Ø3.3X11
VO-230606	6	13	20	8	15	Ø3.3X13
VO-230808	8	15	25	9	17	Ø3.3X15.5
VO-231010	10	19	26	11	19	Ø4.3X19
VO-231212	12	21	29	12	21	Ø4.3X21.5
VO-231414	14	23	30	13	21	Ø4.3X23.5
VO-231616	16	26	31	15	22	Ø4.3X26

Union Tee

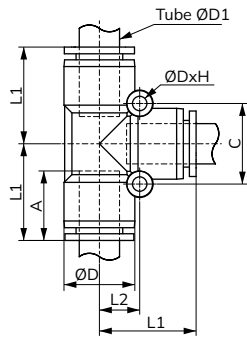

Model No.	Tube OD ØD1	ØD	L1	L2	C	A	ØDXH
VO-250404	4	10.6	17.7	6.5	13	14.9	Ø3.3X11
VO-250606	6	12.8	20	7.5	15	16	Ø3.3X13
VO-250808	8	15	24	9	18	17.2	Ø3.3X15.5
VO-251010	10	18.5	26.4	11	22	19.2	Ø4.3X19
VO-251212	12	21.1	28.8	12	24	20.7	Ø4.3X20.5
VO-251414	14	23.1	29.8	13	26	20.7	Ø4.3X23.5
VO-251616	16	25.6	31.3	14.5	29	22.2	Ø4.3X26

Union Tee Reducer

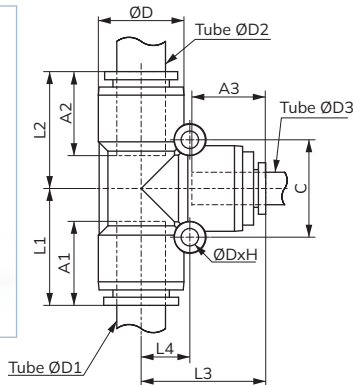

Model No.	Tube OD			ØD	L1	L2	L3	L4	C	A1	A2	A3	ØDXH
	ØD1	ØD2	ØD3										
VO-26040406	4	4	6	12.6	22.8	22.8	20	7.5	15	12.4	12.4	16	Ø3.3X13
VO-26060604	6	6	4	12.6	20	20	22.8	7.5	15	16	16	12.4	Ø3.3X13
VO-26060608	6	6	8	15	26	26	24	9	18	16.3	16.3	17.2	Ø3.3X15.5
VO-26061212	6	12	12	21.1	30.2	28.8	28.8	12	24	17.3	20.7	20.7	Ø4.3X20.5
VO-26080806	8	8	6	15	24	24	26	9	18	17.2	17.2	16.3	Ø3.3X15.5
VO-26080810	8	8	10	18.5	28.7	28.7	26.4	11	22	17.7	17.7	19.2	Ø4.3X19
VO-26081212	8	12	12	21.1	30.7	28.8	28.8	12	24	18.2	20.7	20.7	Ø4.3X24
VO-26101006	10	10	6	18.5	26.4	26.4	28.2	11	22	19.2	19.2	17.2	Ø4.3X19
VO-26101008	10	10	8	18.5	26.4	26.4	28.7	11	22	19.2	19.2	17.7	Ø4.3X19
VO-26101012	10	10	12	21.1	31.2	31.2	28.8	12	24	20.2	20.2	20.7	Ø4.3X20.5
VO-26121206	12	12	6	21.1	28.8	28.8	30.2	12	24	20.7	20.7	17.3	Ø4.3X20.5
VO-26121208	12	12	8	21.1	28.8	28.8	30.7	12	24	20.7	20.7	18.2	Ø4.3X20.5
VO-26121210	12	12	10	21.1	28.8	28.8	30.2	12	24	20.7	20.7	20.2	Ø4.3X20.5

Union 'Y'

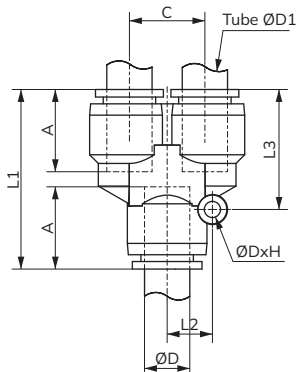

Model No.	Tube OD ØD1	ØD	L1	L2	L3	C	A	ØDXH
VO-270404	4	10.6	31.4	6.5	21.3	10	14.9	Ø3.3X11
VO-270606	6	12.8	34	7.5	22.5	12	16	Ø3.3X13
VO-270808	8	15	39	9	26.5	14.5	17.2	Ø3.3X15.5
VO-271010	10	18.5	45.3	11	29.9	18	19.2	Ø4.3X19
VO-271212	12	21.1	47.6	12	31.8	20	21.8	Ø4.3X21.5

Union 'Y' Reducer

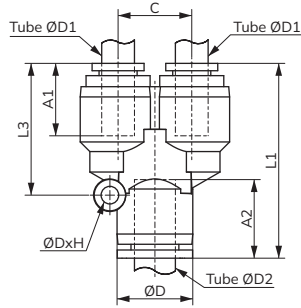

Model No.	Tube OD		ØD	L1	L2	L3	C	A1	A2	ØDxH
	ØD1	ØD2								
VO-28040406	4	6	12.6	36.8	7.5	25.3	12	15.9	16	Ø3.3X13
VO-28060608	6	8	15	41.1	9	28.6	14.5	16.3	17.2	Ø3.3X15.5
VO-28080810	8	10	18.5	47.6	11	32.2	18	19.2	17.7	Ø4.3X19

Bulk Head Union

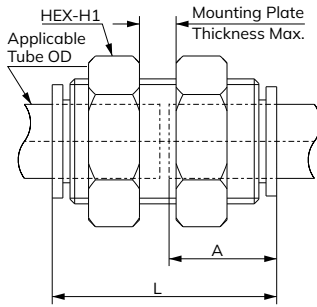

Model No.	Tube OD	HEX	L	A	Mounting Plate Thickness Max.	Mounting Hole Dia.
VO-2904	4	14	32	15	16	13
VO-2906	6	17	33	16	14	15
VO-2908	8	19	34	16	12	17
VO-2910	10	24	38	18	12	21
VO-2912	12	27	39	19	12	23
VO-2914	14	30	40	19	10	25
VO-2916	16	32	49	24	12	28

Male Connector

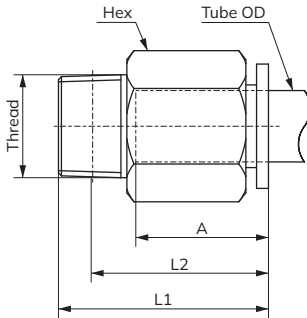

Model No.	Tube OD	Thread	Hex	L1	L2	A
VO-3004A	4	M5 x 0.8	10	21.2	17.2	14.4
VO-3004C		R1/4	14	18.2	12.7	14.4
VO-3004B		R1/8	10	21.7	18	14.4
VO-3006A	6	M5 x 0.8	12	21.5	17.5	15.3
VO-3006B		R1/8	12	22.5	19	16.3
VO-3006C		R1/4	14	25	19.75	16.3
VO-3006D		R3/8	17	20	14.74	16.3
VO-3008B	8	R1/8	14	25	21	16.7
VO-3008C		R1/4	14	27	21.75	17
VO-3008D		R3/8	17	23	16.5	16.7
VO-3008E		R1/2	22	25	18	17
VO-3010C	10	R1/4	17	29.9	23.9	19.7
VO-3010D		R3/8	17	29.9	23.9	19.7
VO-3010E		R1/2	22	25.4	17.9	18.7
VO-3012C	12	R1/4	22	36.8	30.8	22.3
VO-3012D		R3/8	22	35.3	29.55	22.3
VO-3012E		R1/2	22	32.8	25.3	22.3
VO-3012G		G1/4	22	36.8	30.8	22.3
VO-3012I		G3/8	22	35.3	29.46	22.3
VO-3012J		G1/2	22	32.8	25.3	22.3
VO-3014J	14	G1/2	24	33.8	26.3	22.2
VO-3014H		G3/4	27	33.8	26.3	22.2
VO-3016J	16	G1/2	24	38.3	30.3	23.7
VO-3016H		G3/4	27	32.3	23.8	21.7
VO-3016K		G1	36	38.3	28.8	23.7

Bulk Head Female Connector

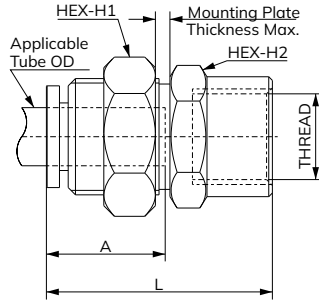

Model No.	Tube OD	Thread	HEX H1	HEX H2	L	A	Mounting Plate Thickness Max.	Mounting Hole Dia.
VO-3106G	6	G1/4	17	17	32	16	8	15
VO-3108G	8	G1/4	19	17	32	16	7	17

Female Connector

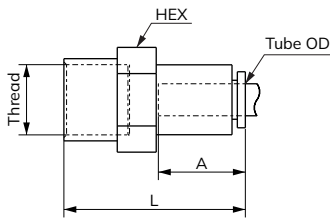

Model No.	Tube OD	Thread	Hex	L	A
VO-3204F	4	G1/8	14	27	14.5
VO-3204G		G1/4	17	31	14.5
VO-3206F	6	G1/8	14	27	15.5
VO-3206G		G1/4	17	31.5	15.5
VO-3208F	8	G1/8	14	27	16
VO-3208G		G1/4	17	31.5	16
VO-3208I	10	G3/8	22	33.5	16
VO-3210G		G1/4	17	33	18
VO-3210I	12	G3/8	22	35	18
VO-3212I		G3/8	22	35	18.5
VO-3212J	14	G1/2	27	39.5	18.5
VO-3214J		G1/2	27	39	19

Male Elbow

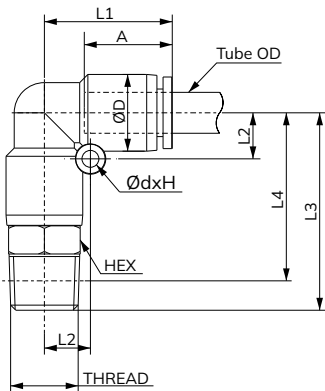

Model No.	Tube OD	Thread	HEX	ØD	L1	L2	L3	L4	A	ØdxH
VO-3304A	4	M5X0.8	9	11	18	7	25	20	15	3.3x11
VO-3304B		R1/8	10	11	18	7	30	27	15	3.3x11
VO-3304C		R1/4	14	11	18	7	32	27	15	3.3x11
VO-3306A	6	M5X0.8	11	13	20	8	28	25	15	3.3x13
VO-3306B		R1/8	12	13	20	8	32	28	15	3.3x13
VO-3306C		R1/4	14	13	20	8	34	28	15	3.3x13
VO-3306D		R3/8	17	13	20	8	35	29	15	3.3x13
VO-3308B	8	R1/8	14	15	25	9	35	31	17	3.3x15.5
VO-3308C		R1/4	14	15	25	9	39	33	17	3.3x15.5
VO-3308D		R3/8	17	15	25	9	37	31	17	3.3x15.5
VO-3308E		R1/2	22	15	25	9	42	35	17	3.3x15.5
VO-3310C		10	R1/4	17	19	26	11	42	37	19
VO-3310D	R3/8		17	19	26	11	42	36	19	4.3x19
VO-3310E	R1/2		22	19	26	11	46	38	19	4.3x19
VO-3312C	12	R1/4	19	21	29	12	45	39	21	4.3x21.5
VO-3312D		R3/8	19	21	29	12	45	39	21	4.3x21.5
VO-3312E		R1/2	22	21	29	12	47	40	21	4.3x21.5
VO-3314J	14	G1/2	22	23	30	13	51	43	21	4.3x26
VO-3314H		G3/4	27	23	30	13	52	43	21	4.3x26
VO-3316J	16	G1/2	24	26	31	15	54	47	22	4.3x26
VO-3316H		G3/4	27	26	31	15	54	45	22	4.3x26
VO-3316K		G1	36	26	31	15	61	51	22	4.3x26

Female Elbow

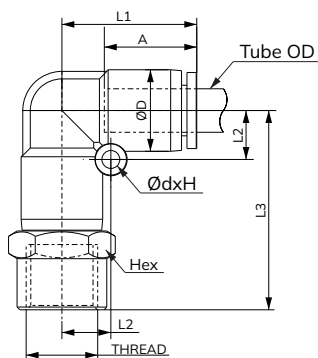

Model No.	Tube OD	Thread	HEX	ØD	L1	L2	L3	A	ØdXH
VO-3506F	6	G1/8	14	13	20	8	28	15	3.3x11
VO-3506G		G1/4	17	13	20	8	33	15	3.3x11
VO-3508G	8	G1/4	17	15	25	9	37	17	3.3x15.5
VO-3514J	14	G1/2	27	23	29	13	46	21	4.3x23.5

Male Branch Tee

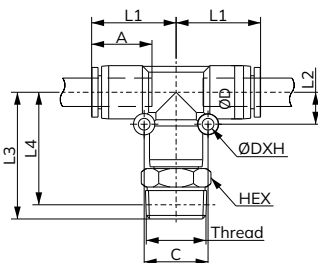

Model No.	Tube OD	Thread	HEX	ØD	L1	L2	L3	L4	C	ØdXH
VO-3604B	4	R1/8	10	10.5	18.5	6.5	30	27	13	3.3 x11
VO-3604C		R1/4	14	10.5	18.5	6.5	32	27	13	3.3 x11
VO-3606B	6	R1/8	12	12.5	20	7.5	31.5	28	15	3.3 x13
VO-3606C		R1/4	14	12.5	20	7.5	33.5	28	15	3.3 x13
VO-3608B	8	R1/8	14	15	22	9	33.5	30	18	3.3 x15.5
VO-3608C		R1/4	14	15	22	9	37	32	18	3.3 x15.5
VO-3608D	10	R3/8	17	15	22	9	36.5	31	18	3.3 x15.5
VO-3610C		R1/4	17	18.5	26	11	41.5	36	22	4.3 x19
VO-3610D	R3/8	17	18.5	26	11	42	36	22	4.3 x19	
VO-3612D	12	R3/8	19	21	27.5	12	44.5	39	24	4.3 x20.5
VO-3612E		R1/2	22	21	27.5	12	47	40	24	4.3 x20.5
VO-3614E	14	R1/2	22	23	29	13	50.5	43	26	4.3 x26

Female Branch Tee

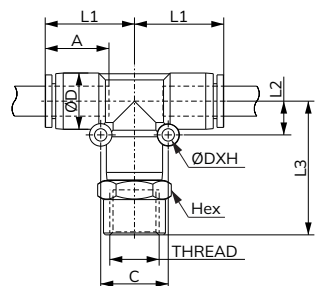

Model No.	Tube OD	Thread	HEX	ØD	L1	L2	L3	C	A	ØdXH
VO-3706F	6	G1/8	14	13	20	8	28	15	16	3.3 x13
VO-3706G		G1/4	17	13	20	8	33	15	16	3.3 x13
VO-3708G	8	G1/4	17	15	22	9	34	18	16	3.3 x15.5

Female Run Tee

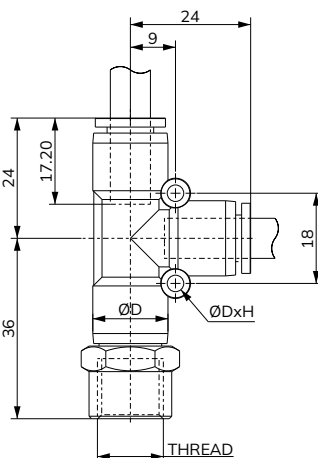

Model No.	Tube OD	Thread	HEX	ØD	L1	L2	L3	C	A	ØdXH
VO-3906F	6	G1/8	14	13	20	8	28	15	16	3.3 x13
VO-3906G		G1/4	17	13	20	8	33	15	16	3.3 x13
VO-3908G	8	G1/4	17	15	22	9	34	18	16	3.3 x15.5

Male Run Tee

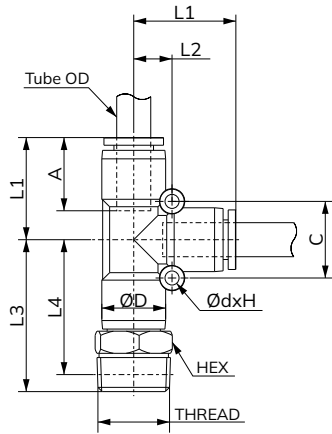

Model No.	Tube OD	Thread	HEX	ØD	L1	L2	L3	L4	C	ØdxH
VO-3804B	4	R1/8	10	10.5	18.5	6.5	30	26.5	13	3.3 x11
VO-3804C		R1/4	14	10.5	18.5	6.5	32	26.5	13	3.3 x11
VO-3806B	6	R1/8	12	12.5	20	7.5	31.5	28	15	3.3 x13
VO-3806C		R1/4	14	12.5	20	7.5	33.5	28	15	3.3 x13
VO-3808B	8	R1/8	14	15	22	9	33.5	30	18	3.3 x15.5
VO-3808C		R1/4	14	15	22	9	37	31.5	18	3.3 x15.5
VO-3808D		R3/8	17	15	22	9	36.5	30.5	18	3.3 x15.5
VO-3810C	10	R1/4	17	18.5	26	11	41.5	36	22	4.3 x19
VO-3810D		R3/8	17	18.5	26	11	42	36	22	4.3 x19
VO-3812D	12	R3/8	19	21	27.5	12	44.5	38.5	24	4.3 x20.5
VO-3812E		R1/2	22	21	27.5	12	47	39.5	24	4.3 x20.5

Male Branch Y

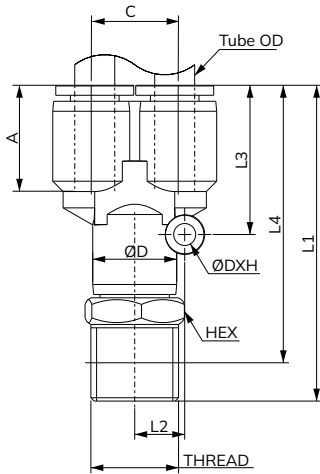

Model No.	Tube OD	Thread	HEX	ØD	L1	L2	L3	L4	C	A	ØDXH
VO-4004B	4	R1/8	10	11	43	7	19	39	10	15	3.3 X 11
VO-4004C		R1/4	14	11	45	7	19	39	10	15	3.3 X11
VO-4006B	6	R1/8	12	13	46	8	22	43	12	16	3.3 X13
VO-4006C		R1/4	14	13	48	8	22	43	12	16	3.3 X13
VO-4008B	8	R1/8	14	15	50	9	25	46	15	16	3.3 X15.5
VO-4008C		R1/4	14	15	53	9	25	48	15	16	3.3 X15.5
VO-4008D		R3/8	17	15	53	9	25	47	15	16	3.3 X15.5
VO-4010C	10	R1/4	17	19	60	11	30	54	18	18	4.3 X19
VO-4010D		R3/8	17	19	60	11	30	54	18	18	4.3 X19
VO-4012D	12	R3/8	19	21	64	12	32	58	20	19	4.3 X21.5
VO-4012E		R1/2	22	21	67	12	32	59	20	19	4.3 X21.5

Male Connector (Internal Hexagon Socket)

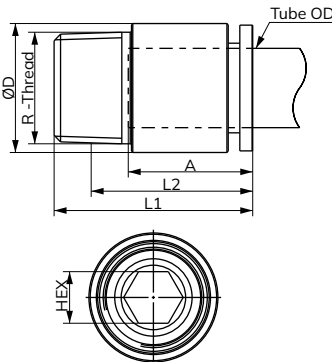

Model No.	Tube OD	Thread	HEX	ØD	L1	L2	A
VO-4104A	4	M5 X 0.8	2	10.5	21	17.5	14.5
VO-4104B		R1/8	2.5	10.5	21.5	18	14.5
VO-4104C		R1/4	2.5	13.5	17.5	12	14.5
VO-4106A	6	M5 X 0.8	2	12.5	22	18.5	15.5
VO-4106B		R1/8	4	12.5	23	19.5	15.5
VO-4106C		R1/4	4	13.5	22.5	17	15.5
VO-4106D		R3/8	4	17	19	13	15.5
VO-4108B	8	R1/8	4	14.5	25.5	22	16
VO-4108C		R1/4	6	14.5	27	21.5	16
VO-4108D		R3/8	6	17	22.5	16.5	16
VO-4108E		R1/2	6	21.5	21.5	14	16
VO-4110B	10	R1/8	4	18	28	24.5	18
VO-4110C		R1/4	6	18	29.5	24	18
VO-4110D		R3/8	6	18	30	24	18
VO-4110E		R1/2	6	21.5	23.5	16	18
VO-4112C	12	R1/4	6	20	32	26.5	18.5
VO-4112D		R3/8	8	20	30.5	24.5	18.5
VO-4112E		R1/2	8	21.5	32.5	25	18.5

Single Swivel (Internal Hexagon Socket)

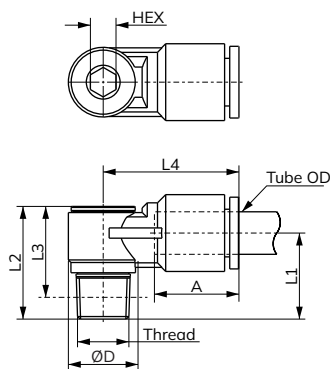

Model No.	Tube OD	Thread	HEX	ØD	L1	L2	L3	L4	A
VO-4204B	4	R1/8	5	13.5	15	22	18.5	22	14.5
VO-4206B	6	R1/8	5	13.5	15.5	22	18.5	23	15.5
VO-4206C		R1/4	6	18	20	28.5	23	25	15.5
VO-4208B	8	R1/8	5	13.5	17.5	22	18.5	27	17
VO-4208C		R1/4	6	18	20.5	28.5	23	27.5	17
VO-4208D		R3/8	8	22	23	32.5	26.5	29.5	17
VO-4208E		R1/2	10	28	26.5	38	30.5	32.5	17
VO-4210C	10	R1/4	6	18	22.5	28.5	23	32.5	20
VO-4210D		R3/8	8	22	24	32.5	26.5	34.5	20
VO-4210E		R1/2	10	28	27.5	38	30.5	36.5	20
VO-4212D	12	R3/8	8	22	25	32.5	26.5	36	20.5
VO-4212E		R1/2	10	28	28.5	38	30.5	37.5	20.5

Single Swivel (Slotted Head)

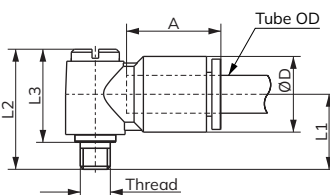

Model No.	Tube OD	Thread	ØD	L1	L2	L3	A
VO-4304A	4	M5X0.8	10.5	12.5	20	16.5	14.5
VO-4306A	6	M5X0.8	12.5	12.5	20	16.5	15.5

Single Swivel (Hexagon Head)

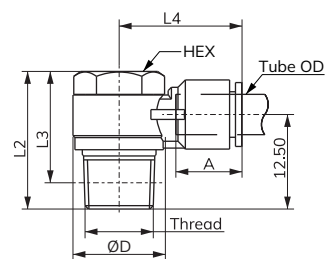

Model No.	Tube OD	Thread	HEX	ØD	L1	L2	L3	L4	A
VO-4404B	4	R1/8	12	13.5	15	24.5	21	22	14.5
VO-4406B	6	R1/8	12	13.5	15.5	24.5	21	23	15.5
VO-4406C		R1/4	14	18	20	30.5	25	25	15.5
VO-4408B	8	R1/8	12	13.5	17.5	24.5	21	27	17
VO-4408C		R1/4	14	18	20.5	30.5	25	27.5	17
VO-4408D		R3/8	19	22	23	36.5	30.5	29.5	17
VO-4408E		R1/2	24	28	26.5	42	34.5	32.5	17
VO-4410C	10	R1/4	14	18	22.5	30.5	25	32.5	20
VO-4410D		R3/8	19	22	24	36.5	30.5	34.5	20
VO-4410E		R1/2	24	28	27.5	42	34.5	36.5	20
VO-4412D	12	R3/8	19	22	25	36.5	30.5	36	20.5
VO-4412E		R1/2	24	28	28.5	42	34.5	37.5	20.5

Double Swivel

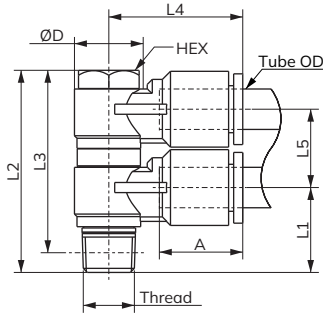

Model No.	Tube OD	Thread	HEX	ØD	L1	L2	L3	L4	L5	A
VO-4504B	4	R1/8	12	13.5	15	40	36.5	22	15.5	14.5
VO-4506B	6	R1/8	12	13.5	15.5	40	36.5	23	15.5	15.5
VO-4506C		R1/4	14	18	20	50	44.5	25	19.4	15.5
VO-4508B	8	R1/8	12	13.5	17.5	40	36.5	27	15.5	17
VO-4508C		R1/4	14	18	20.5	50	44.5	27.5	19.4	17
VO-4508D		R3/8	19	22	23	58.5	52.5	29.5	21.6	17
VO-4508E		R1/2	24	28	26.5	63.5	56	32.5	21.5	17
VO-4510C	10	R1/4	14	18	22.5	50	44.5	32.5	19.4	20
VO-4510D		R3/8	19	22	24	58.5	52.5	34.5	21.6	20
VO-4510E		R1/2	24	28	27.5	56	56	36.5	21.5	20
VO-4512D	12	R3/8	19	22	25	52.5	52.5	36	21.6	20.5
VO-4512E		R1/2	24	28	28.5	56	56	37.5	21.5	20.5

Triple Swivel

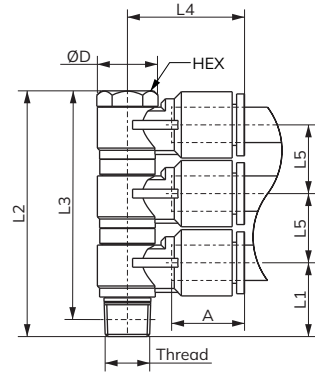

Model No.	Tube OD	Thread	HEX	ØD	L1	L2	L3	L4	L5	A
VO-4604B	4	R1/8	12	13.5	15	55.5	52	22	15.5	14.5
VO-4606B	6	R1/8	12	13.5	15.5	55.5	52	23	15.5	15.5
VO-4606C		R1/4	14	18	20	69.5	64	25	19.4	15.5
VO-4608B	8	R1/8	12	13.5	17.5	55.5	52	27	15.5	17
VO-4608C		R1/4	14	18	20.5	69.5	64	27.5	19.4	17
VO-4608D		R3/8	19	22	23	80	74	29.5	21.6	17
VO-4608E		R1/2	24	28	26.5	85	77.5	32.5	21.5	17
VO-4610C	10	R1/4	14	18	22.5	69.5	64	32.5	19.4	20
VO-4610D		R3/8	19	22	24	80	74	34.5	21.6	20
VO-4610E		R1/2	24	28	27.5	85	77.5	36.5	21.5	20
VO-4612D	12	R3/8	19	22	25	80	74	36	21.6	20.5
VO-4612E		R1/2	24	28	28.5	85	77.5	37.5	21.5	20.5

Multi Distributor Union

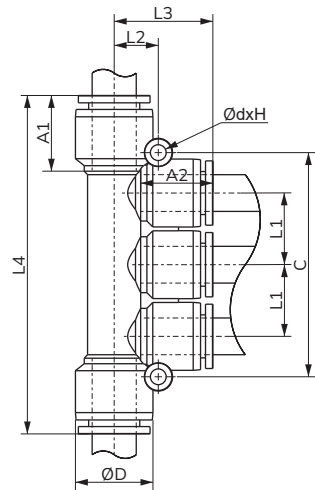

Model No.	Tube OD		ØD	L1	L2	L3	L4	C	A1	A2	ØDXH
	ØD1	ØD2									
VO-470604	6	4	12.5	11.5	8	19	60.5	37	15.5	14.5	Ø4.3X13
VO-470804	8	4	15	11.5	9	20	63	37	17	14.5	Ø4.3X15.5
VO-470806	8	6	15	13.5	9	21	71	43	17	15.5	Ø4.3X15.5
VO-471006	10	6	18.5	13.5	11	22	76	43	20	15.5	Ø4.3X19
VO-471008	10	8	18.5	16	11	24	82	51	20	17	Ø4.3X19
VO-471208	12	8	21	16	12	24	84.5	51	20.5	17	Ø4.3X21.5
VO-471210	12	10	21	19.5	12	27.5	92.5	61	20.5	20	Ø4.3X21.5

Multi Distributor Male

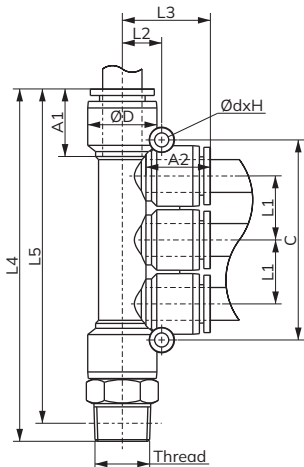

Model No.	Tube OD		Thread	Hex	ØD	L1	L2	L3	L4	L5	C	A1	A2	Thread
	ØD1	ØD2												
VO-480604B	6	4	R1/8	12	12.5	11.5	8	19	72	68.5	37	15.5	14.5	Ø4.3X13
VO-480604C	6	4	R1/4	14	12.5	11.5	8	19	74	68.5	37	15.5	14.5	Ø4.3X13
VO-480604D	6	4	R3/8	17	12.5	11.5	8	19	75	69	37	15.5	15.5	Ø4.3X13
VO-480804B	8	4	R1/8	14	15	11.5	9	20	74.5	71	37	17	14.5	Ø4.3X15.5
VO-480804C	8	4	R1/4	14	15	11.5	9	20	78	72.5	37	17	14.5	Ø4.3X15.5
VO-480804D	8	4	R3/8	17	15	11.5	9	20	77.5	71.5	37	17	14.5	Ø4.3X15.5
VO-480806B	8	6	R1/8	14	15	13.5	9	21	82.5	79	43	17	15.5	Ø4.3X15.5
VO-480806C	8	6	R1/4	14	15	13.5	9	21	86	80.5	43	17	15.5	Ø4.3X15.5
VO-480806D	8	6	R3/8	17	15	13.5	9	21	85.5	79.5	43	17	15.5	Ø4.3X15.5
VO-481006C	10	6	R1/4	17	18.5	13.5	11	22	91.5	86	43	20	15.5	Ø4.3X19
VO-481006D	10	6	R3/8	17	18.5	13.5	11	22	92	86	43	20	15.5	Ø4.3X19
VO-481006E	10	6	R1/2	22	18.5	13.5	11	22	95.5	88	43	20	15.5	Ø4.3X19
VO-481008C	10	8	R1/4	17	18.5	16	11	24	97.5	92	51	20	17	Ø4.3X19
VO-481008D	10	8	R3/8	17	18.5	16	11	24	98	92	51	20	17	Ø4.3X19
VO-481008E	10	8	R1/2	22	18.5	16	11	24	101.5	94	51	20	17	Ø4.3X19
VO-481208D	12	8	R3/8	19	21	16	12	24	101	95	51	20.5	17	Ø4.3X21.5
VO-481208E	12	8	R1/2	22	21	16	12	24	103.5	96	51	20.5	17	Ø4.3X21.5
VO-481210D	12	10	R3/8	19	21	19.5	12	27.5	109	103	61	20.5	20	Ø4.3X21.5
VO-481210E	12	10	R1/2	22	21	19.5	12	27.5	111.5	104	61	20.5	20	Ø4.3X21.5

Cross Union

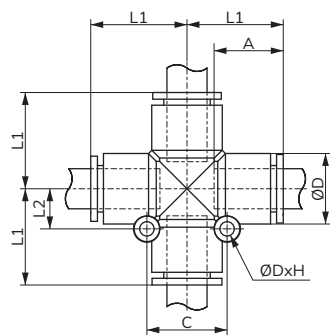

Model No.	Tube OD	ØD	L1	L2	C	A	ØDXH
VO-490404	4	10.6	17.7	6.5	13	14.9	Ø3.3X11
VO-490606	6	12.6	20	7.5	15	16	Ø3.3X13
VO-490808	8	15	25	9	18	17.2	Ø3.3X15.5
VO-491010	10	18.5	26.4	11	22	19.2	Ø4.3X19
VO-491212	12	21.1	28.8	12	24	20.7	Ø4.3X21.5

Plug

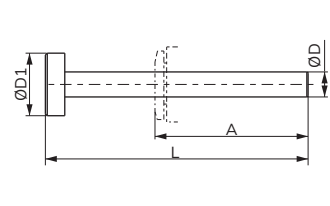

Model No.	Applicable Fitting size ØD	ØD1	L	A
VO-5004	4	10	42	15
VO-5006	6	12	44	16
VO-5008	8	14	46	17
VO-5010	10	16	48	20
VO-5012	12	18	52	21
VO-5014	14	20	45	22
VO-5016	16	18	47	23

Specifications

Type	Supply control	Exhaust control
Model	VF52	VF55
Free flow	2 → 1	1 → 2
Controlled flow	1 → 2	2 → 1
Media	Compressed air - Dry / Lubricated	
Operating pressure range	1 - 10 bar	
Ambient Temperature	+5° to +60° C	
Materials of construction	Brass, Acetal, Nitrile	
Applicable tubes	Nylon, Polyurethane	

Features

- ☑ Directly mountable on cylinder / valve ports
- ☑ Can be rotated by 360°
- ☑ Fine regulation of air flow
- ☑ Nickel plated body
- ☑ Male threads(R) teflon coated
- ☑ Elegant design and finish

Application

- ☑ These valves are used to control the speed of piston in a pneumatic cylinder.

Function

- ☑ These valves allow controlled flow of air in one direction and free flow in the other direction.
- ☑ These are available in two versions - a) Supply control version, and b) Exhaust control version.

Symbol

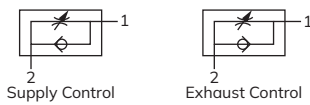

Flow Control - R Series

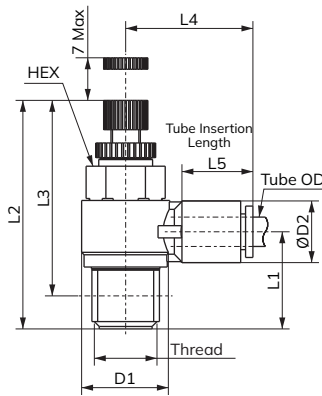

Model No.	Thread	Tube OD	Hex	L1	L2	L3	L4	L5	ØD1	ØD2	Free Flow Min. Lts/min	Control Flow Min. Lts/min
VF-5204B	R1/8	4		15.5	39	35.5	22	14.5	13.5	10.5	100	100
VF-5504B												
VF-5206B		6	12	16	39	35.5	23	15.5	13.5	12.5	200	140
VF-5506B												
VF-5208B	R1/4	8		18	39	35.5	27	17	13.5	15	200	140
VF-5508B												
VF-5206C		6		20.5	47	41.5	25	15.5	18	12.5	400	350
VF-5506C												
VF-5208C	R3/8	8	14	21	47	41.5	27.5	17	18	15	550	420
VF-5508C												
VF-5210C		10		23	47	41.5	32.5	20	18	18.5	650	450
VF-5510C												
VF-5208D	R1/2	8		25	53	47	29.5	17	22	15	1100	930
VF-5508D												
VF-5210D		10	19	26	53	47	34.5	20	22	18.5	1300	1000
VF-5510D												
VF-5212D	R3/8	12		27	53	47	36	20.5	22	21	1400	1050
VF-5512D												
VF-5208E		8		27.5	57	49.5	32.5	17	28	15	1400	1250
VF-5508E												
VF-5210E	R1/2	10	24	28.5	57	49.5	36.5	20	28	18.5	1750	1500
VF-5510E												
VF-5212E		12		29.5	57	49.5	37.5	20.5	28	21	1900	1600
VF-5512E												

Flow Control - M Series

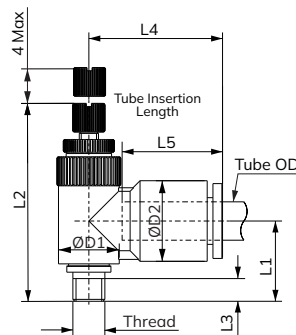

Model No.	Thread	Tube OD	L1	L2	L3	L4	L5	ØD1	ØD2	Free Flow Min. Lts/min	Control Flow Min. Lts/min	
VF-5204A	M5	4	12.5	31	3.5	20	14.5	9.5	10.5	60	45	
VF-5504A												
VF-5206A		6	12.5	31	3.5	21	15.5	9.5	12.5	100	50	
VF-5506A												

VO - SERIES ONE TOUCH FITTINGS MODEL IDENTIFICATION CHART

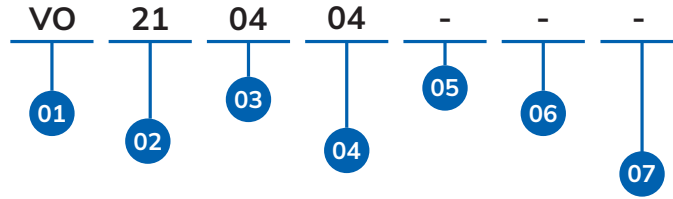

01	SERIES
-	VO

04	APPLICABLE TUBING OD
-	BLANK
04	TO Ø04MM
06	TO Ø06MM
08	TO Ø08MM
10	TO Ø10MM
12	TO Ø12MM
14	TO Ø14MM
16	TO Ø16MM

05	APPLICABLE TUBING OD
-	BLANK
04	TO Ø04MM
06	TO Ø06MM
08	TO Ø08MM
10	TO Ø10MM
12	TO Ø12MM
14	TO Ø14MM
16	TO Ø16MM

02	PRODUCT TYPE	
21	Straight Union	38 Male Run Tee
22	Different Dia. Straight Union	39 Female Run Tee
23	Union Elbow	40 Male Branch 'Y'
24	Union Elbow Reducer	41 Male Connector (Internal Hexagon Socket)
25	Union Tee	42 Single Swivel (Internal Hexagon Socket)
26	Union Tee Reducer	43 Single Swivel (Slotted Head)
27	Union 'Y'	44 Single Swivel (Hexagon Head)
28	Union 'Y' Reducer	45 Double Swivel
29	Bulk Head Union	46 Triple Swivel
30	Male Connector	47 Multi Distributor Union
31	Bulk Head Female Connector	48 Multi Distributor Male
32	Female Connector	49 Cross Union
33	Male Elbow	50 Plug
34	Extended Male Elbow	53 Self Sealing
35	Female Elbow	54 Male Straight
36	Male Branch Tee	56 Double Branch Male Elbow
37	Female Branch Tee	

06	THREAD	
-	BLANK	K 1" BSP
A	M5X0.8	L 1/8" NPT
B	1/8" BSPT	M 1/4" NPT
C	1/4" BSPT	N 3/8" NPT
D	3/8" BSPT	O 1/2" NPT
E	1/2" BSPT	P 1/2" BSW (8 ANI)
F	1/8" BSP	Q 3/4" NPT
G	1/4" BSP	S M6X1
I	3/8" BSP	T M12X1.5
J	1/2" BSP	U 3/4" BSPT

03	APPLICABLE TUBING OD
04	With Applicable Tubing Od Ø04mm
06	With Applicable Tubing Od Ø06mm
08	With Applicable Tubing Od Ø08mm
10	With Applicable Tubing Od Ø10mm
12	With Applicable Tubing Od Ø12mm
14	With Applicable Tubing Od Ø14mm
16	With Applicable Tubing Od Ø16mm

07	CONFIGURATION
-	REGULAR
C1	CONFIG 1
C2	CONFIG 2
C3	CONFIG 3
⋮	⋮
C9	CONFIG 9
CA	CONFIG 10
CB	CONFIG 11

08	VERSION
-	VERSION 0
V1	VERSION 1
V2	VERSION 2
V3	VERSION 3
⋮	⋮
V9	VERSION 9
VA	VERSION 10
VB	VERSION 11

VF - SERIES FLOW CONTROL MODEL CHART

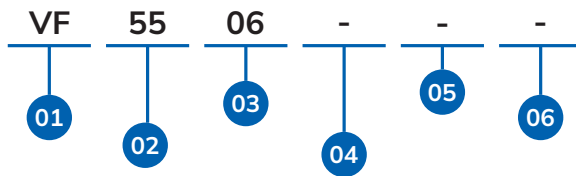

01	SERIES
	VF

02	PRODUCT TYPE
51	Inline Type
52	Supply Type
55	Exhaust Type

03	APPLICABLE TUBING OD
04	With Applicable Tubing Od Ø04mm
06	With Applicable Tubing Od Ø06mm
08	With Applicable Tubing Od Ø08mm
10	With Applicable Tubing Od Ø10mm
12	With Applicable Tubing Od Ø12mm

04	THREAD TYPE
-	BLANK
A	M5X0.8
B	1/8" BSPT
C	1/4" BSPT
D	3/8" BSPT
E	1/2" BSPT
F	1/8" BSP
G	1/4" BSP
I	3/8" BSP
J	1/2" BSP

05	CONFIGURATION
-	REGULAR
C1	CONFIG 1
C2	CONFIG 2
C3	CONFIG 3
⋮	⋮
C9	CONFIG 9
CA	CONFIG 10
CB	CONFIG 11

06	VERSION
-	VERSION 0
V1	VERSION 1
V2	VERSION 2
V3	VERSION 3
⋮	⋮
V9	VERSION 9
VA	VERSION 10
VB	VERSION 11

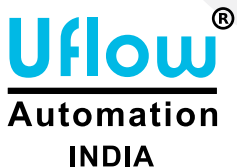

VF-5506E
1/2" BSPT EXHAUST TYPE FLOW CONTROL WITH
APPLICABLE TUBING OD Ø06MM



PLASTIC TUBINGS
SERIES

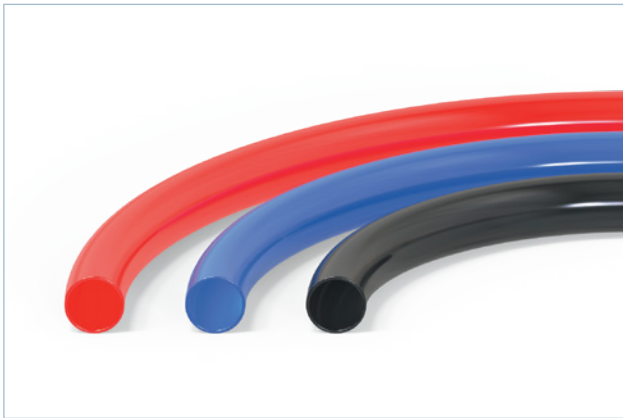

Advantages

Provide differentiation of air line in pneumatic circuits

Usage Instructions

- Cut the tube - end burr free and square, using Tube cutter and clean the edge to ensure leak tight joints. (Do not use blunt tools / hacksaw / chisel etc.,)
- Ensure the tube is fully inserted into the fitting - until the positive stop, beyond the 'U' seal.
- For ensuring proper insertion, pull the tube gently by hand. Polyurethane tube will yield and come out if pulled heavily.
- Minimum bend radius of the tubing to avoid leakage

Recommended Pressure vs Working Temperature

Maximum Pressure :	10 bar	9 bar	8 bar	7 bar
	5°C to 30°C	30°C to 40°C	40°C to 50°C	50°C to 60°C
Ambient temperature :				

Specification for Polyurethane Tube

Tube OD	Tube ID	Minimum bend radius (in mm)	Blue	Black	Red	Yellow	Silver	Transparent
4	2	10	PU-0402	PU-0402K	PU-0402R	PU-0402Y	PU-0402S	PU-0402T
6	4	15	PU-0604	PU-0604K	PU-0604R	PU-0604Y	PU-0604S	PU-0604T
8	5	25	PU-0805	PU-0805K	PU-0805R	PU-0805Y	PU-0805S	PU-0805T
10	7	30	PU-1007	PU-1007K	PU-1007R	PU-1007Y	PU-1007S	PU-1007T
12	8	35	PU-1208	PU-1208K	PU-1208R	PU-1208Y	PU-1208S	PU-1208T
14	10	130	PU-1410	PU-1410K	PU-1410R	PU-1410Y	PU-1410S	PU-1410T
16	11	140	PU-1611	PU-1611K	PU-1611R	PU-1611Y	PU-1611S	PU-1611T

Specification for Nylon Tube N6

Tube OD	Tube ID	Minimum bend radius (in mm)	Blue	Black	Red	Yellow	Silver	Transparent
4	2	20	N6-0402	N6-0402K	N6-0402R	N6-0402Y	N6-0402S	N6-0402T
6	4	40	N6-0604	N6-0604K	N6-0604R	N6-0604Y	N6-0604S	N6-0604T
8	6	50	N6-0806	N6-0806K	N6-0806R	N6-0806Y	N6-0806S	N6-0806T
10	8	60	N6-1008	N6-1008K	N6-1008R	N6-1008Y	N6-1008S	N6-1008T
12	10	80	N6-1210	N6-1210K	N6-1210R	N6-1210Y	N6-1210S	N6-1210T
14	12	100	N6-1412	N6-1412K	N6-1412R	N6-1412Y	N6-1412S	N6-1412T

Specification for Nylon Tube N12

Tube OD	Tube ID	Minimum bend radius (in mm)	Blue	Black	Red	Yellow	Silver	Transparent
4	2.5	20	N1-0425	N1-0425K	N1-0425R	N1-0425Y	N1-0425S	N1-0425T
6	4	40	N1-0604	N1-0604K	N1-0604R	N1-0604Y	N1-0604S	N1-0604T
8	6	50	N1-0806	N1-0806K	N1-0806R	N1-0806Y	N1-0806S	N1-0806T
10	8	60	N1-1008	N1-1008K	N1-1008R	N1-1008Y	N1-1008S	N1-1008T
12	9	80	N1-1209	N1-1209K	N1-1209R	N1-1209Y	N1-1209S	N1-1209T
14	12	100	N1-1412	N1-1412K	N1-1412R	N1-1412Y	N1-1412S	N1-1412T

PU - SERIES PU TUBING MODEL CHART

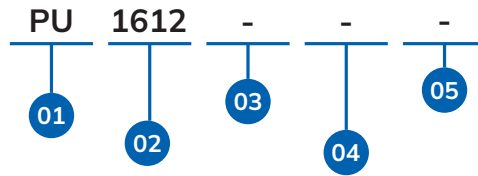

01	SERIES
	PU

02	APPLICABLE TUBING OD & ID
0402	Ø4MM - Ø2MM
0604	Ø6MM - Ø4MM
0805	Ø8MM - Ø5MM
1007	Ø10MM - Ø7MM
1208	Ø12MM - Ø8MM
1410	Ø14MM - Ø10MM
1611	Ø16MM - Ø11MM
1612	Ø16MM - Ø12MM

03	COLOR
-	Blue
T	Transparent
K	Black
R	Red
Y	Yellow
S	Silver
N	Natural
G	Green
TB	Translucent Blue
TK	Translucent Black
TR	Translucent Red
TY	Translucent Yellow
TG	Translucent Green

04	CONFIGURATION
-	REGULAR
C1	CONFIG 1
C2	CONFIG 2
C3	CONFIG 3
⋮	⋮
C9	CONFIG 9
CA	CONFIG 10
CB	CONFIG 12

05	VERSION
-	VERSION 0
V1	VERSION 1
V2	VERSION 2
V3	VERSION 3
⋮	⋮
V9	VERSION 9
VA	VERSION 10
VB	VERSION 11

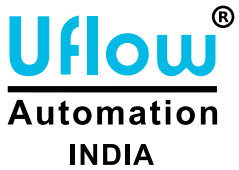

PU-1612
PU TUBE OD Ø16MM ID Ø12MM BLUE

Note: The above chart is for identification purposes only, and it may not be possible to make all combinations for the above chart.

PE - SERIES POLYETHYLENE TUBING MODEL CHART

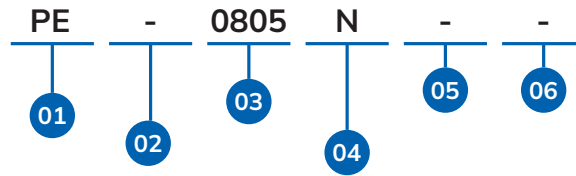

01	SERIES
	PE

02	TYPE
	Polyethylene Tube

03	APPLICABLE TUBING OD & ID
0402	Ø4MM - Ø2MM
0604	Ø6MM - Ø4MM
0805	Ø8MM - Ø5MM
1007	Ø10MM - Ø7MM
1208	Ø12MM - Ø8MM

04	COLOR
-	Blue
T	Transparent
K	Black
R	Red
Y	Yellow
S	Silver
N	Natural
G	Green

05	CONFIGURATION
-	REGULAR
C1	CONFIG 1
C2	CONFIG 2
C3	CONFIG 3
⋮	⋮
C9	CONFIG 9
CA	CONFIG 10
CB	CONFIG 12

06	VERSION
-	VERSION 0
V1	VERSION 1
V2	VERSION 2
V3	VERSION 3
⋮	⋮
V9	VERSION 9
VA	VERSION 10
VB	VERSION 11

PE-0805N
POLYETHYLENE TUBE OD Ø8MM ID Ø5MM NATURAL

Note: The above chart is for identification purposes only, and it may not be possible to make all combinations for the above chart.

N1 - SERIES NYLON TUBING MODEL CHART

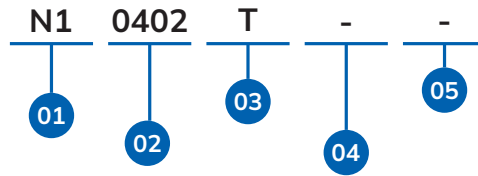

01	SERIES
	N1

02	APPLICABLE TUBING OD & ID
0402	Ø4MM - Ø2MM
0425	Ø4MM - Ø2.5MM
0604	Ø6MM - Ø4MM
0806	Ø8MM - Ø6MM
1008	Ø10MM - Ø8MM
1210	Ø12MM - Ø10MM
1412	Ø14MM - Ø12MM

03	COLOR
-	Blue
T	Transparent
K	Black
R	Red
Y	Yellow
S	Silver
N	Natural

04	CONFIGURATION
-	REGULAR
C1	CONFIG 1
C2	CONFIG 2
C3	CONFIG 3
⋮	⋮
C9	CONFIG 9
CA	CONFIG 10
CB	CONFIG 12

05	VERSION
-	VERSION 0
V1	VERSION 1
V2	VERSION 2
V3	VERSION 3
⋮	⋮
V9	VERSION 9
VA	VERSION 10
VB	VERSION 11

N1-0402T
NYLON TUBE OD Ø4MM ID Ø2MM TRANSPARENT

Note: The above chart is for identification purposes only, and it may not be possible to make all combinations for the above chart.

N6 - SERIES NYLON TUBING MODEL CHART

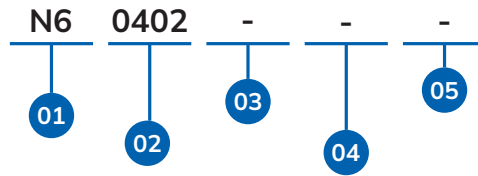

01	SERIES
	N6

02	APPLICABLE TUBING OD & ID
0402	Ø4MM - Ø2MM
0425	Ø4MM - Ø2.5MM
0604	Ø6MM - Ø4MM
0806	Ø8MM - Ø6MM
1008	Ø10MM - Ø8MM
1210	Ø12MM - Ø10MM
1412	Ø14MM - Ø12MM

03	COLOR
-	Blue
T	Transparent
K	Black
R	Red
Y	Yellow
S	Silver
N	Natural

04	CONFIGURATION
-	REGULAR
C1	CONFIG 1
C2	CONFIG 2
C3	CONFIG 3
⋮	⋮
C9	CONFIG 9
CA	CONFIG 10
CB	CONFIG 12

05	VERSION
-	VERSION 0
V1	VERSION 1
V2	VERSION 2
V3	VERSION 3
⋮	⋮
V9	VERSION 9
VA	VERSION 10
VB	VERSION 11

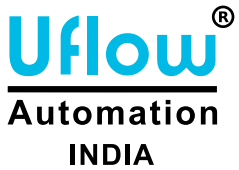

N6-0402
 NYLON TUBE OD Ø4MM ID Ø2MM BLUE

Note: The above chart is for identification purposes only, and it may not be possible to make all combinations for the above chart.

TRANSLUCENT PU TUBING MODEL CHART

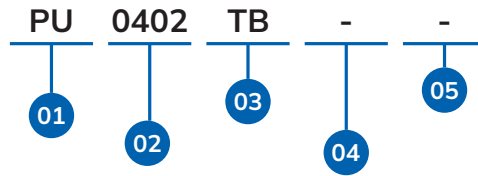

01	SERIES
	PU
	PUS

02	APPLICABLE TUBING OD & ID
0402	Ø4MM - Ø2MM
0604	Ø6MM - Ø4MM
0805	Ø8MM - Ø5MM
0855	Ø8MM - Ø5.5MM
1006	Ø10MM - Ø6MM
1007	Ø10MM - Ø7MM
1208	Ø12MM - Ø8MM
1410	Ø14MM - Ø10MM
1611	Ø16MM - Ø11MM
1612	Ø16MM - Ø12MM

03	COLOR
TB	Translucent Blue
TK	Translucent Black
TR	Translucent Red
TY	Translucent Yellow
TG	Translucent Green

04	CONFIGURATION
-	REGULAR
C1	CONFIG 1
C2	CONFIG 2
C3	CONFIG 3
⋮	⋮
C9	CONFIG 9
CA	CONFIG 10
CB	CONFIG 12

05	VERSION
-	VERSION 0
V1	VERSION 1
V2	VERSION 2
V3	VERSION 3
⋮	⋮
V9	VERSION 9
VA	VERSION 10
VB	VERSION 11

PU-0402
PU TUBE OD Ø4MM ID Ø2MM TRANSLUCENT BLUE

Note: The above chart is for identification purposes only, and it may not be possible to make all combinations for the above chart.

PUS - SERIES PU SPIRAL TUBING MODEL CHART

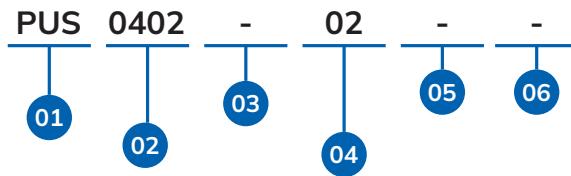

01	SERIES
	PUS

02	APPLICABLE TUBING OD & ID
0402	Ø4MM - Ø2MM
0604	Ø6MM - Ø4MM
0805	Ø8MM - Ø5MM
0855	Ø8MM - Ø5.5MM
1007	Ø10MM - Ø7MM
1208	Ø12MM - Ø8MM

03	COLOR
-	Blue
T	Transparent
K	Black
R	Red
Y	Yellow
S	Silver
N	Natural
G	Green
TB	Translucent Blue
TK	Translucent Black
TR	Translucent Red
TY	Translucent Yellow
TG	Translucent Green

04	WORKING LENGTH
02	2 Meter
04	4 Meter
06	6 Meter
08	8 Meter
10	10 Meter
12	12 Meter

05	CONFIGURATION
-	REGULAR
C1	CONFIG 1
C2	CONFIG 2
C3	CONFIG 3
⋮	⋮
C9	CONFIG 9
CA	CONFIG 10
CB	CONFIG 12

06	VERSION
-	VERSION 0
V1	VERSION 1
V2	VERSION 2
V3	VERSION 3
⋮	⋮
V9	VERSION 9
VA	VERSION 10
VB	VERSION 11

PUS-040202
PU SPIRAL TUBE OD Ø4MM ID Ø2MM BLUE 2 METER

Note: The above chart is for identification purposes only, and it may not be possible to make all combinations for the above chart.



**POPPET VALVE
SERIES**



Valve Specifications

Type :	3/2
Design :	Internal Pilot Operated Poppet Valve
Port Size :	In / Out / Exhaust - 1/4" BSP (Available in NPT)
Media :	Compressed Air (Filtered & Lubricated)
working Pressure Range :	2-10 Bar
Orifice :	7mm
Flow Factor :	18 kv (LPM of Water @ 1 bar ΔP)
Ambient / Media Temperature :	5°C - 60°C
Materials of Construction :	Aluminium, Nitrile, Polymer, Brass

Coil Specification

Operating Voltage :	24V AC	110V AC	230V AC	12V DC	24V DC
Power Consumption :	9W	9W	9W	10W	11W
Coil Features :	High Reliability Unaffected by Voltage Surges. Easy coil changes coil lockable in 4X90 position or freely movable in between as require.				
Coil Housing :	IP65 Epoxy square coil, IP65 Metallic round enclosure, IP67 Flameproof Junction box, IP68 Weatherproof enclosure.				

Port Connection

1 - Input, 2 - Output, 3 - Exhaust

Model No.	Valve Type	Function	Symbol
DCP-1B23T070	NC	Single Solenoid Spring Return (NC / NO)	
DCP-1A23T070	NO	Single Solenoid Spring Return (NC / NO)	

Features

- Fast response time 600 cycle/min
- Manual override
- 10 Million cycle tested
- Lubrication not essential

Dimension Drawing (All dimensions in mm)

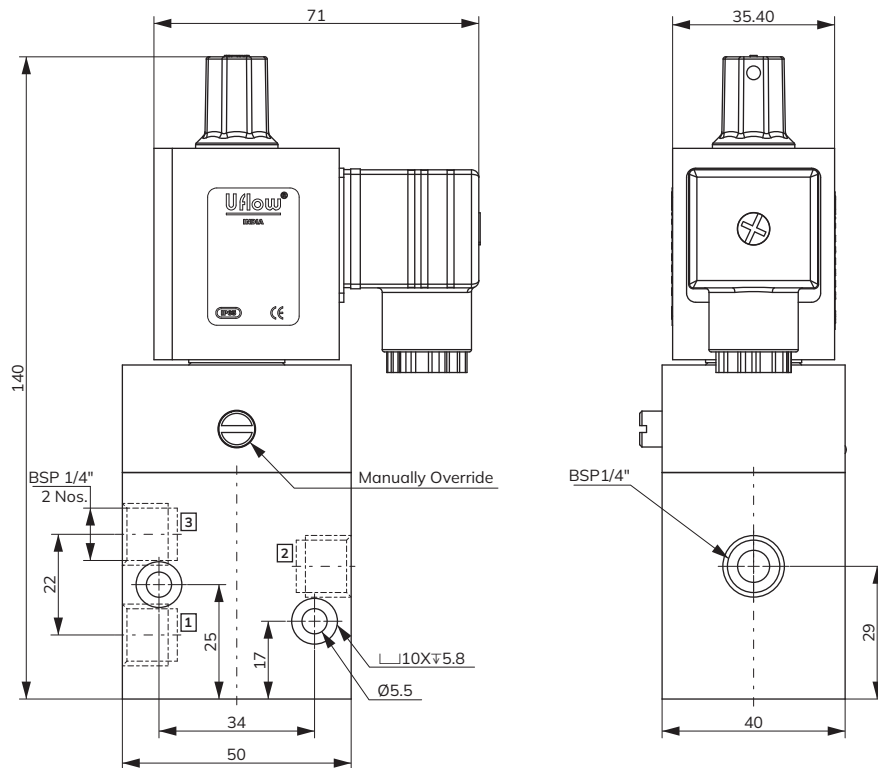



Valve Specifications

Type :
 Design :
 Port Size :
 Media :
 working Pressure Range :
 Orifice :
 Flow Factor :
 Ambient / Media Temperature :
 Materials of Construction :

5/2
 Internal Pilot Operated Poppet Valve
 In / Out / Exhaust - 1/4" BSP (Available in NPT)
 Compressed Air (Filtered & Lubricated)
 2-10 Bar
 7mm
 18 kv (LPM of Water @ 1 bar ΔP)
 5°C - 60°C
 Aluminium, Nitrile, Polymer, Brass

Coil Specification

Operating Voltage :	24V AC	110V AC	230V AC	12V DC	24V DC
Power Consumption :	9W	9W	9W	10W	11W
Coil Features :	High Reliability Unaffected by Voltage Surges. Easy coil changes coil lockable in 4X90 position or freely movable in between as require.				
Coil Housing :	IP65 Epoxy square coil, IP65 Metallic round enclosure, IP67 Flameproof Junction box, IP68 Weatherproof enclosure.				

Port Connection

1 - Input, 2/4 - Output, 3/5 - Exhaust

Model No.	Function	Symbol
DCP-1G23T070	Single Solenoid Spring Return	

Features

- Fast response time 1000 cycle/min
- Manual override
- 10 Million cycle tested
- Lubrication not essential

Dimension Drawing (All dimensions in mm)

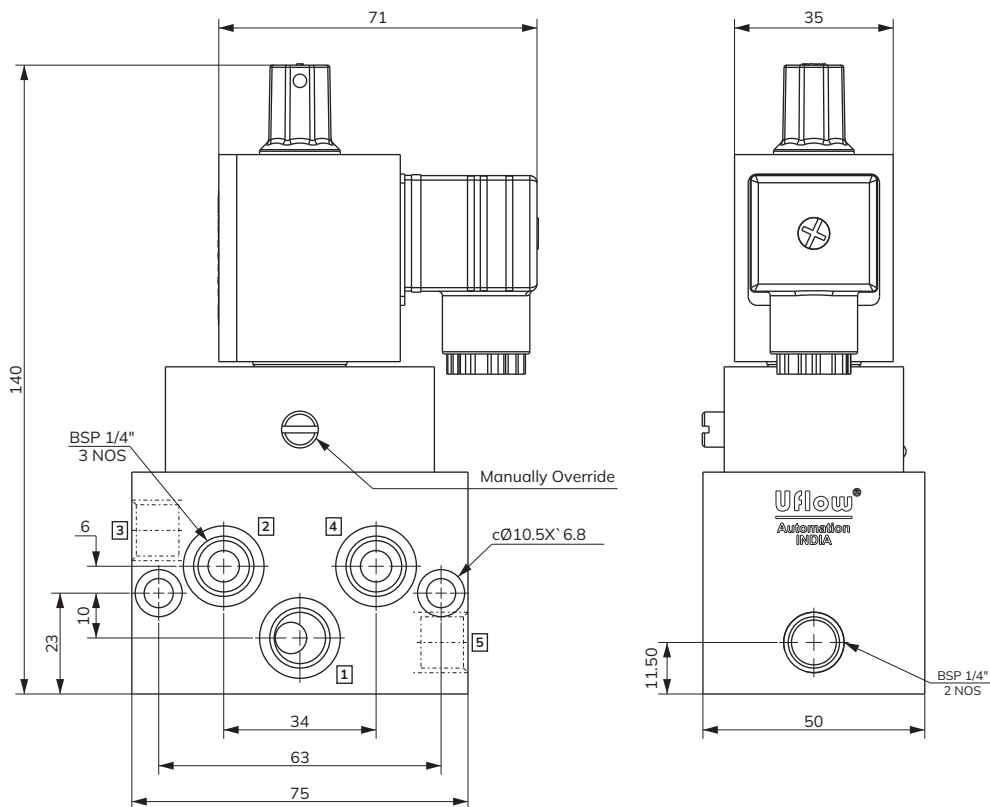



Valve Specifications

Type :	3/2 - 5/2
Design :	Internal Pilot Operated Poppet Valve
Port Size :	In / Exhaust - 1/4" BSP & Out - Namur Hole Pattern (Available in NPT)
Media :	Compressed Air (Filtered & Lubricated)
working Pressure Range :	2-10 Bar
Orifice :	7mm
Flow Factor :	18 kv (LPM of Water @ 1 bar ΔP)
Ambient / Media Temperature :	5°C - 60°C
Materials of Construction :	Aluminium, Nitrile, Polymer, Brass

Coil Specification

Operating Voltage :	24V AC	110V AC	230V AC	12V DC	24V DC
Power Consumption :	9W	9W	9W	10W	11W
Coil Features :	High Reliability Unaffected by Voltage Surges. Easy coil changes coil lockable in 4X90 position or freely movable in between as require.				
Coil Housing :	IP65 Epoxy square coil, IP65 Metallic round enclosure, IP67 Flameproof Junction box, IP68 Weatherproof enclosure.				

Port Connection

1 - Input, 2/4 - Output, 3/5 - Exhaust

Model No.	Function	Symbol
DCP-1RJ23T070	Single Solenoid Spring Return	5X2 3X2

Features

- Fast response time 1000 cycle/min
- Manual override
- 10 Million cycle tested
- Lubrication not essential

Dimension Drawing (All dimensions in mm)

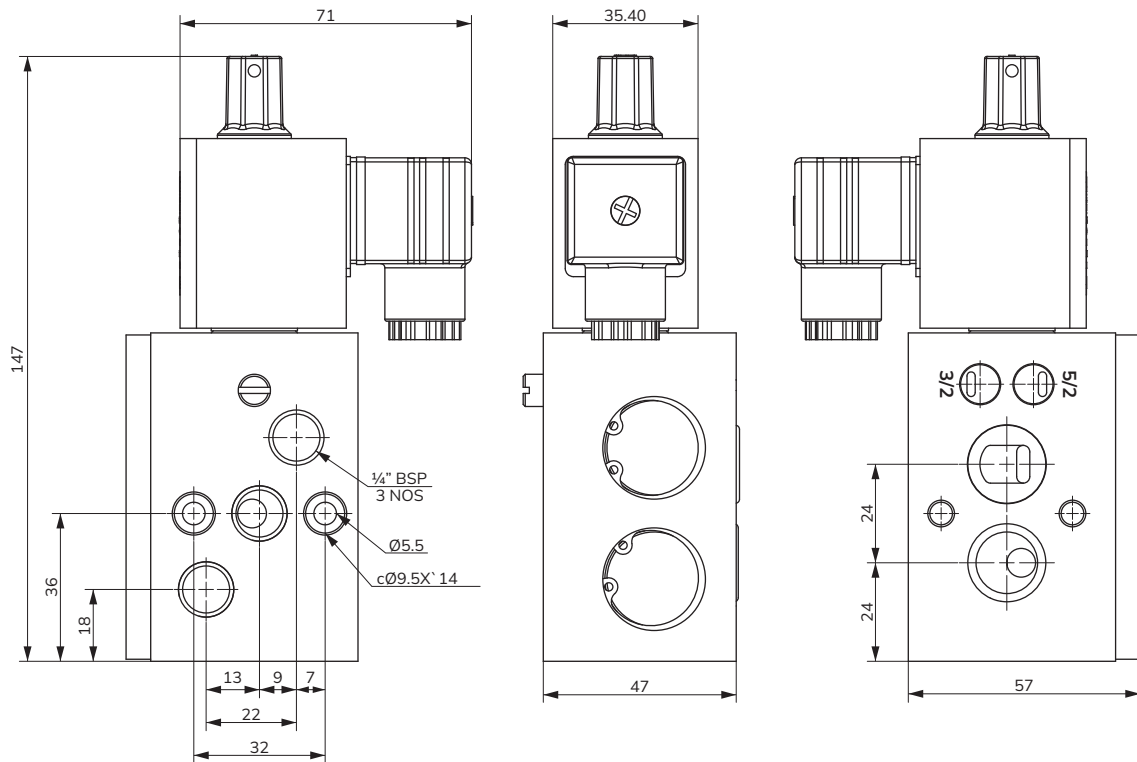



Valve Specifications

Type :	5/2
Design :	Internal Pilot Operated Poppet Valve
Port Size :	In / Out / Exhaust - 1/4" BSP (Available in NPT)
Media :	Compressed Air (Filtered & Lubricated)
working Pressure Range :	2-10 Bar
Orifice :	7mm
Flow Factor :	18 kv (LPM of Water @ 1 bar ΔP)
Ambient / Media Temperature :	5°C - 60°C
Materials of Construction :	Aluminium, Nitrile, Polymer, Brass

Coil Specification

Operating Voltage :	24V AC	110V AC	230V AC	12V DC	24V DC
Power Consumption :	9W	9W	9W	10W	11W
Coil Features :	High Reliability Unaffected by Voltage Surges. Easy coil changes coil lockable in 4X90 position or freely movable in between as require.				
Coil Housing :	IP65 Epoxy square coil, IP65 Metallic round enclosure, IP67 Flameproof Junction box, IP68 Weatherproof enclosure.				

Port Connection

1 - Input, 2/4 - Output, 3/5 - Exhaust

Model No.	Function	Symbol
DCP-1H23P060	Single Solenoid Spring Return	

Features

- Fast response time 1000 cycle/min
- Manual override
- 10 Million cycle tested
- Lubrication not essential

Dimension Drawing (All dimensions in mm)

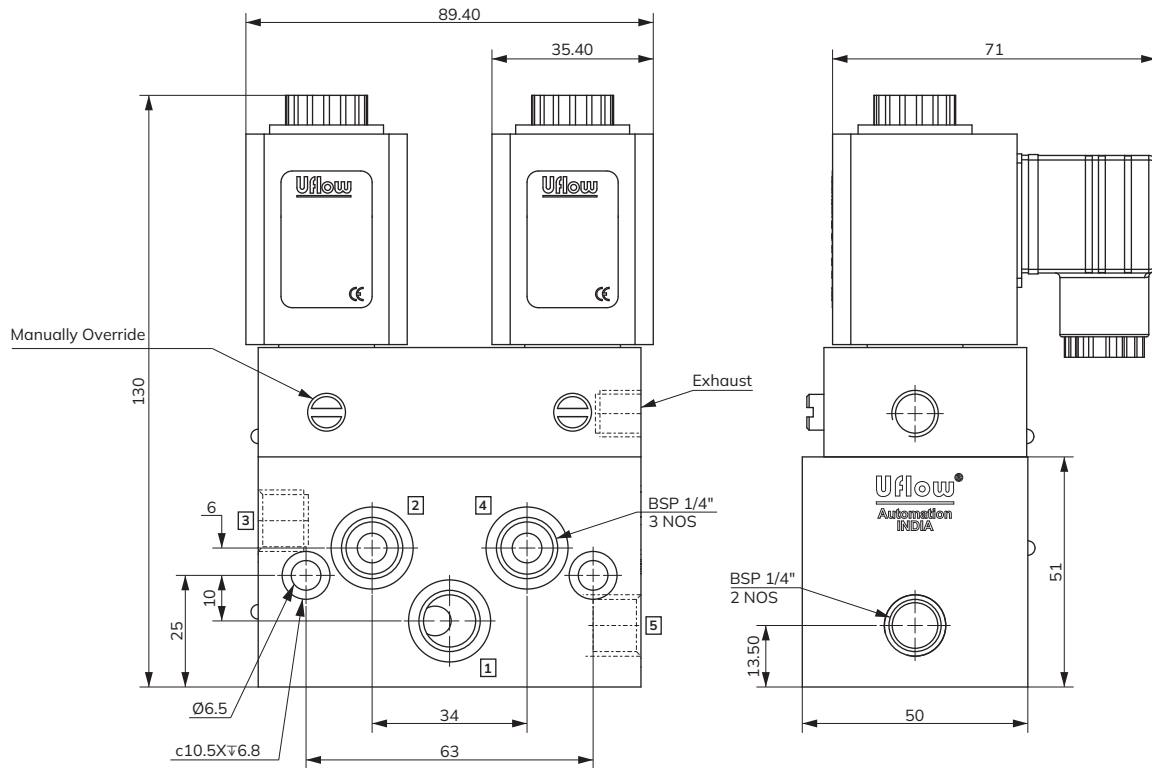



Valve Specifications

Type :	3/2
Design :	Internal Pilot Operated Poppet Valve
Port Size :	In / Out / Exhaust - 1/2" BSP (Available in NPT)
Media :	Compressed Air (Filtered & Lubricated)
working Pressure Range :	2-10 Bar
Orifice :	16mm
Flow Factor :	75 kv (LPM of Water @ 1 bar ΔP)
Ambient / Media Temperature :	5°C - 60°C
Materials of Construction :	Aluminium, Nitrile, Polymer, Brass

Coil Specification

Operating Voltage :	24V AC	110V AC	230V AC	12V DC	24V DC
Power Consumption :	9W	9W	9W	10W	11W
Coil Features :	High Reliability Unaffected by Voltage Surges. Easy coil changes coil lockable in 4X90 position or freely movable in between as require.				
Coil Housing :	IP65 Epoxy square coil, IP65 Metallic round enclosure, IP67 Flameproof Junction box, IP68 Weatherproof enclosure.				

Port Connection

1 - Input, 2 - Output, 3 - Exhaust

Model No.	Function	Symbol
DCP-2B23T160	Single Solenoid	

Features

- Fast response time 600 cycle/min
- Manual override
- 10 Million cycle tested
- Lubrication not essential

Dimension Drawing (All dimensions in mm)

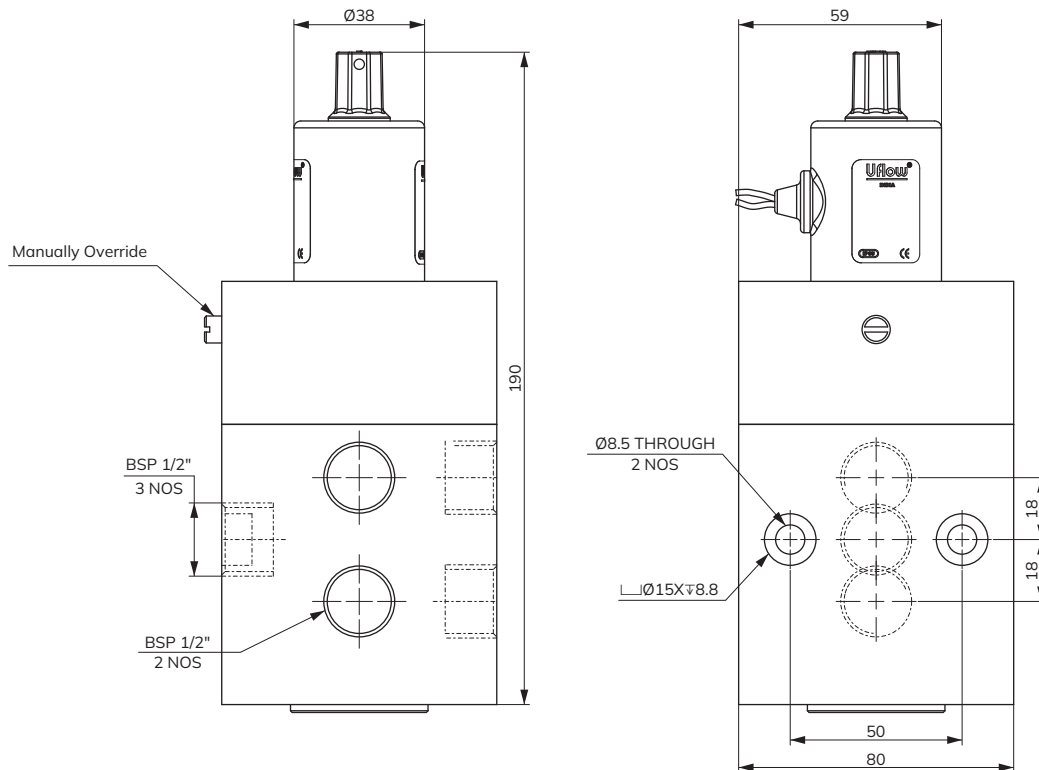



Valve Specifications

Type :	3/2
Design :	3 Way Direct Acting Poppet Type
Port Size :	In / Exhaust - 1/4" BSP & Out - Namur Hole Pattern (Available in NPT)
Media :	Compressed Air (Filtered & Lubricated)
working Pressure Range :	2-10 Bar
Orifice :	7mm
Flow Factor :	18 kv (LPM of Water @ 1 bar ΔP)
Ambient / Media Temperature :	5°C - 60°C
Materials of Construction :	Aluminium, Nitrile, Polymer, Brass

Coil Specification

Operating Voltage :	24V AC	110V AC	230V AC	12V DC	24V DC
Power Consumption :	9W	9W	9W	10W	11W
Coil Features :	High Reliability Unaffected by Voltage Surges. Easy coil changes coil lockable in 4X90 position or freely movable in between as require.				
Coil Housing :	IP65 Epoxy square coil, IP65 Metallic round enclosure, IP67 Flameproof Junction box, IP68 Weatherproof enclosure.				

Port Connection

1 - Input, 2/4 - Output, 3 - Exhaust

Model No.	Function	Symbol
DCP-1RB23T070	Single Solenoid Spring Return	

Features

- Fast response time 1000 cycle/min
- Manual override
- 10 Million cycle tested
- Lubrication not essential

Dimension Drawing (All dimensions in mm)

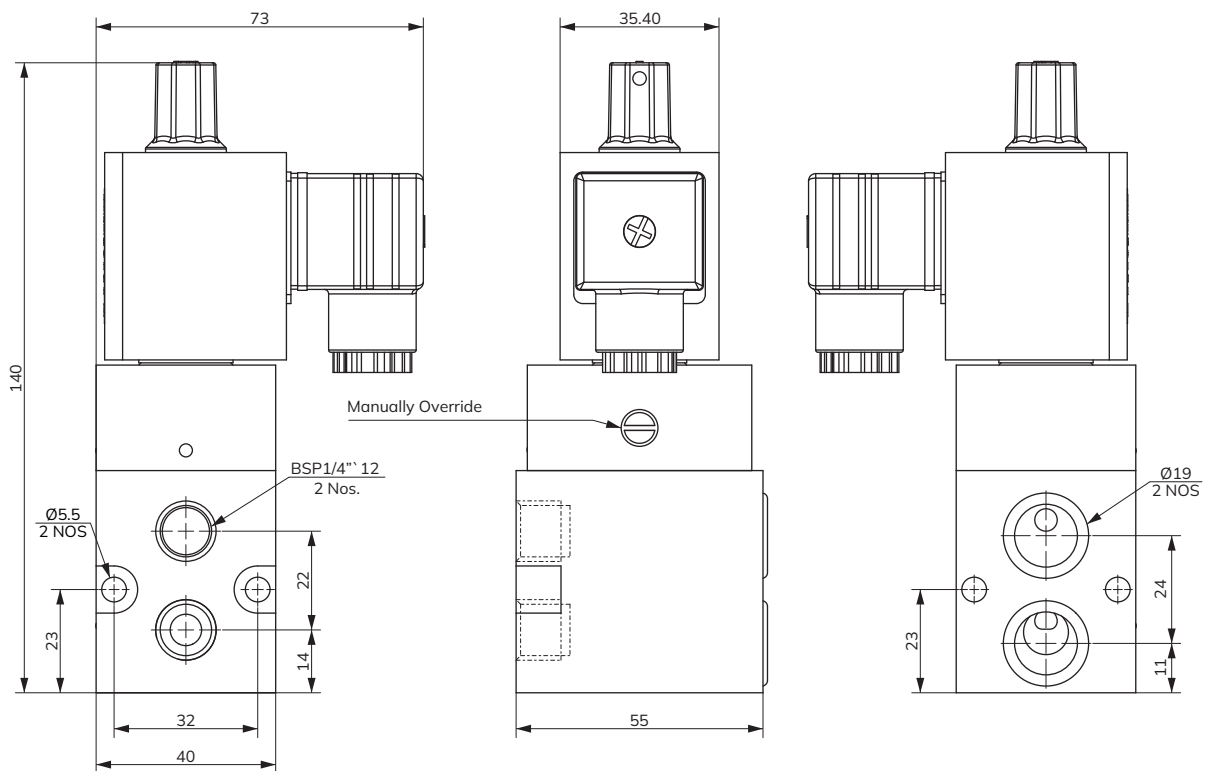



Valve Specifications

Type :	3 Way
Design :	3 Way Direct Acting Poppet Type
Port Size :	In / Out / Exhaust - ¼" BSP (Available in NPT)
Media :	Compressed Air (Filtered & Lubricated)
working Pressure Range :	0-10 Bar
Orifice :	5mm
Flow Factor :	8 kv (LPM of Water @ 1 bar ΔP)
Ambient / Media Temperature :	5°C - 60°C
Materials of Construction :	Aluminium, Nitrile, Polymer, Brass

Coil Specification

Operating Voltage :	24V AC	110V AC	230V AC	24V DC
Power Consumption :	9W	9W	9W	11W
Coil Features :	High Reliability Unaffected by Voltage Surges. Easy coil changes coil lockable in 4X90 position or freely movable in between as require.			
Coil Housing :	IP65 Epoxy square coil, IP65 Metallic round enclosure, IP67 Flameproof Junction box, IP68 Weatherproof enclosure.			

Port Connection

1 - Input, 2/4 - Output, 3 - Exhaust

Model No.	Function	Symbol
DCP-T1RBFT050	Single Solenoid Spring Return	

Features

- Fast response time 1000 cycle/min
- Manual override
- 10 Million cycle tested
- Lubrication not essential

Dimension Drawing (All dimensions in mm)

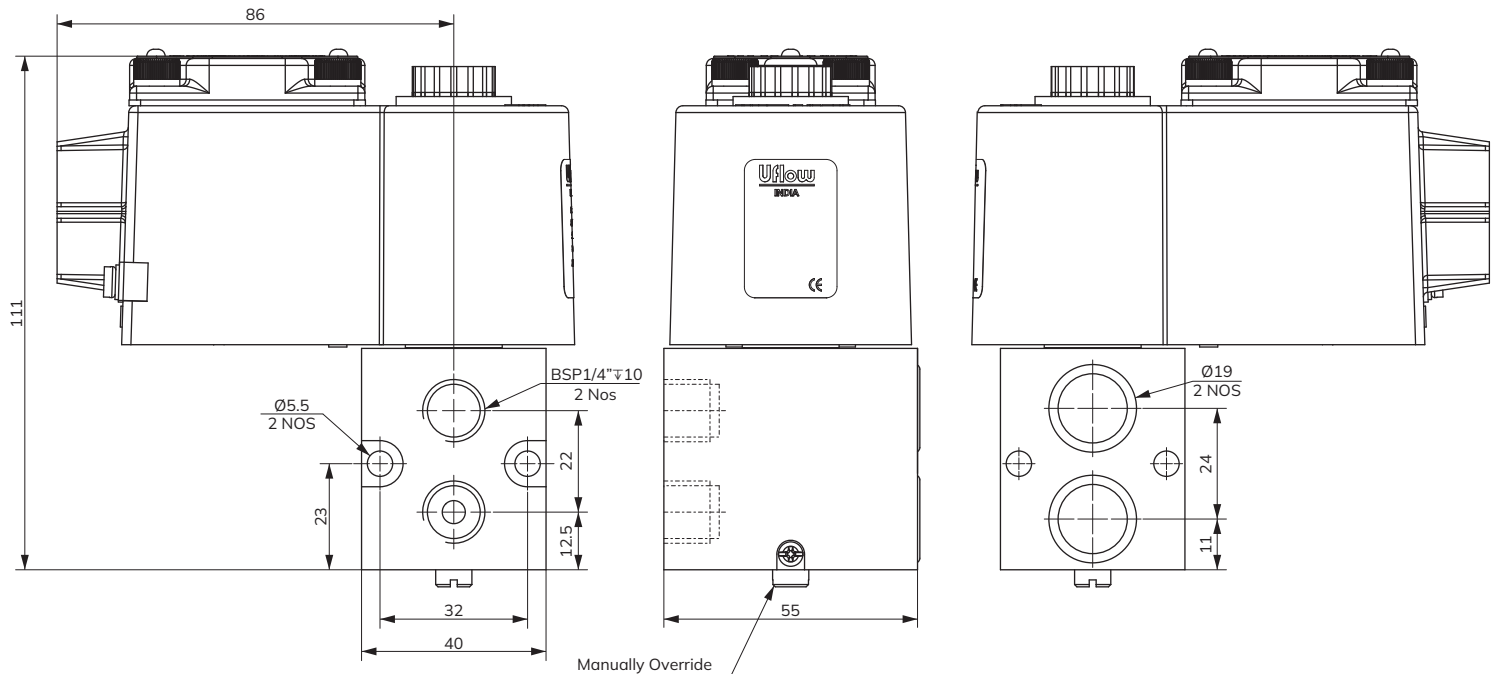



Valve Specifications

Type :
 Design :
 Port Size :
 Media :
 working Pressure Range :
 Orifice :
 Flow Factor :
 Ambient / Media Temperature :
 Materials of Construction :

3 Way	
3 Way Direct Acting Poppet Type	
In / Out / Exhaust - ¼" BSP	In / Out / Exhaust - ½" BSP
Compressed Air (Filtered & Lubricated)	
0-10 Bar	
7mm	10mm
14 kv (LPM of Water @ 1 bar ΔP)	30 kv (LPM of Water @ 1 bar ΔP)
5°C - 60°C	
Aluminium, Nitrile, Polymer, Brass	

Coil Specification

Operating Voltage :
 Power Consumption :
 Coil Features :
 Coil Housing :

24V AC	110V AC	230V AC	12V DC	24V DC
9W	9W	9W	10W	11W

High Reliability Unaffected by Voltage Surges. Easy coil changes coil lockable in 4X90 position or freely movable in between as require.
 IP65 Epoxy square coil, IP65 Metallic round enclosure, IP67 Flameproof Junction box, IP68 Weatherproof enclosure.

Port Connection

1 - Input, 2 - Output, 3 - Exhaust

Model No.	Function	Symbol
DCP-T2U4IT100	Single Solenoid Spring Return	

Features

- Fast response time 1000 cycle/min
- Manual override
- 10 Million cycle tested
- Lubrication not essential

Dimension Drawing (All dimensions in mm)

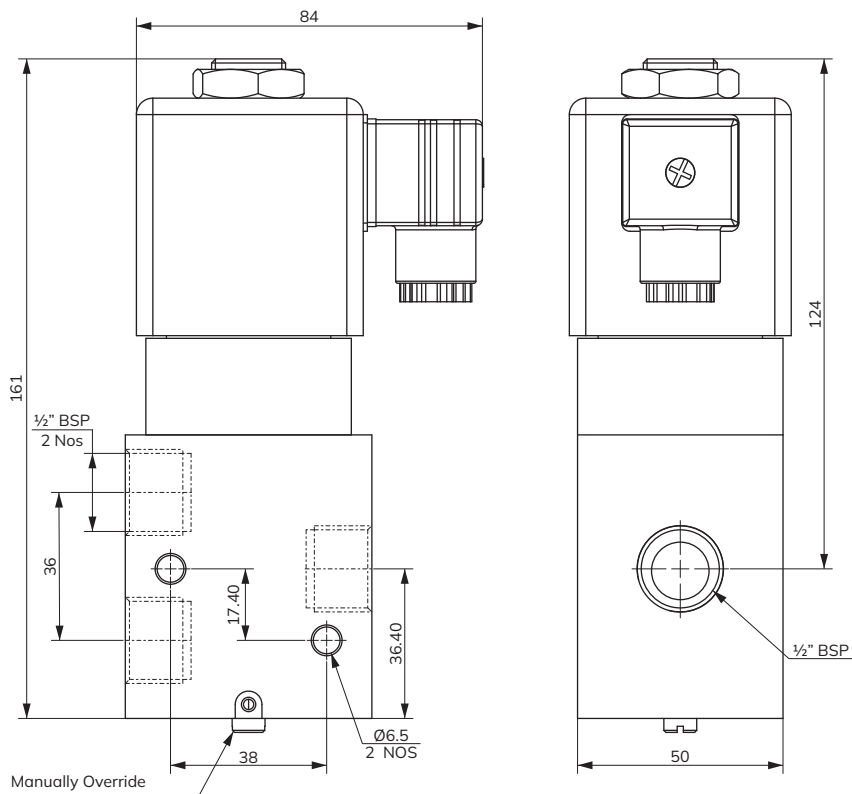

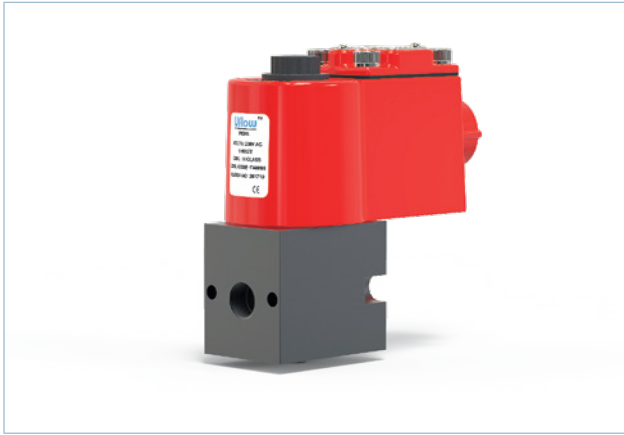

Valve Specifications

Type :	3 Way
Design :	3 Way Direct Acting Poppet Type
Port Size :	In / Out / Exhaust - ¼" BSP (Available in NPT)
Media :	Compressed Air (Filtered & Lubricated)
working Pressure Range :	0-10 Bar
Orifice :	5mm
Flow Factor :	8 kv (LPM of Water @ 1 bar ΔP)
Ambient / Media Temperature :	5°C - 60°C
Materials of Construction :	Aluminium, Nitrile, Polymer, Brass

Coil Specification

Operating Voltage :	24V AC	110V AC	230V AC	24V DC
Power Consumption :	9W	9W	9W	11W
Coil Features :	High Reliability Unaffected by Voltage Surges. Easy coil changes coil lockable in 4X90 position or freely movable in between as require.			
Coil Housing :	IP65 Epoxy square coil, IP65 Metallic round enclosure, IP67 Flameproof Junction box, IP68 Weatherproof enclosure.			

Port Connection

Model No.	Function	Symbol
DCP-T1UFT050	Single Solenoid Spring Return	

1 - Input, 2 - Output, 3 - Exhaust

Features

- Fast response time 1000 cycle/min
- Manual override
- 10 Million cycle tested
- Lubrication not essential
- Universal Type (NO/NC)

Dimension Drawing (All dimensions in mm)

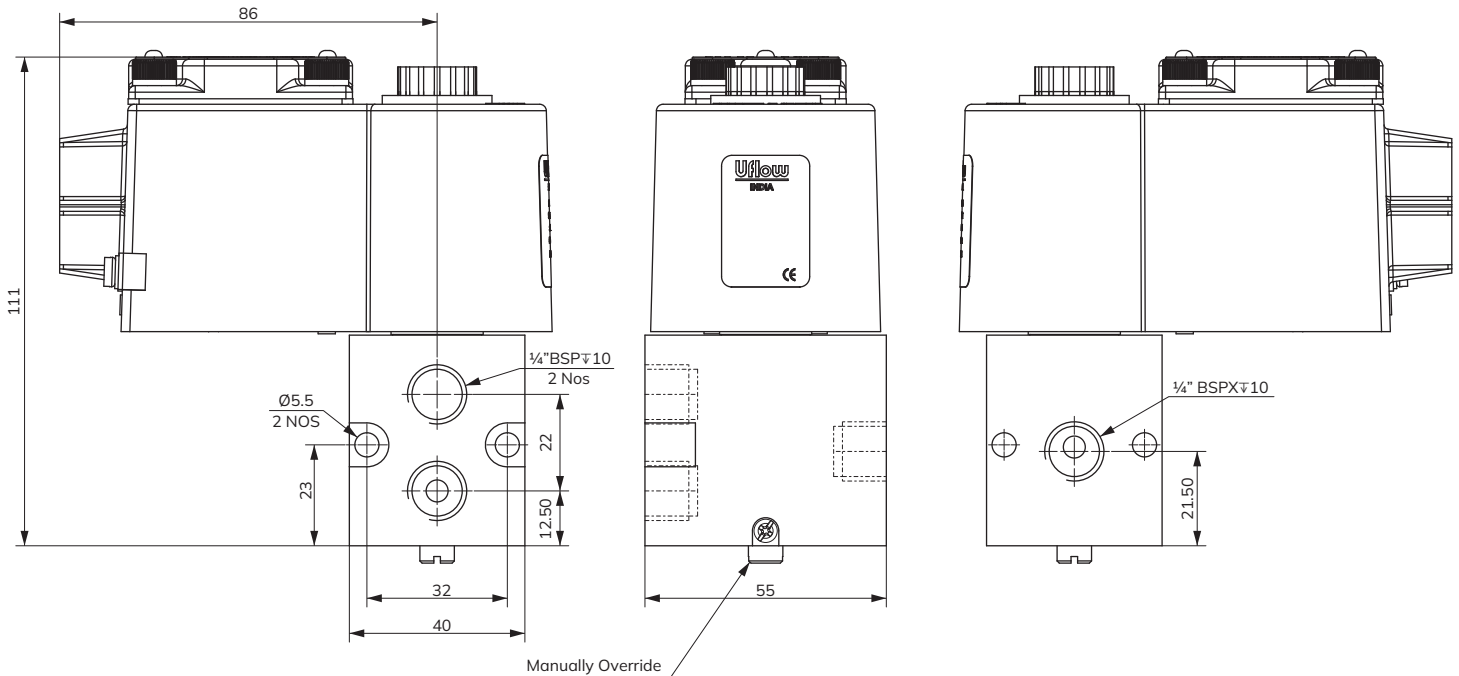



Valve Specifications

Type :	3/2
Design :	External Pilot Operated, Poppet Type
Port Size :	G 1/2" BSP Female
Media :	Compressed Air (Filtered & Lubricated)
Seals:	Nitrile Rubber
Orifice:	13mm
Temperature Range:	5°C to 50°C
Mainline Pressure Range:	3 to 20 bar
External Pilot Pressure Range:	5 to 9 bar
Flow (NLPM) at 5 bar	3600 Normal Litres Per Min.
Coil Voltage:	AC: 24V, 110V, 230V DC: 12V, 24V, 36V, 48V, 110V
Power:	AC: 6W DC: 6W
Duty Cycle:	Continuous
Response Time:	15 msec ON / 25 msec OFF
Protection:	IP65
Other Specification Data:	Available on Request

Port Connection

1 - Input, 2 - Output, 3 - Exhaust, 8 - Pilot In

Model No.	Diagram No.	Symbol
DCP-2B40C130	1.1	
DCP-2F40C130	1.2	

3/2 High Pressure Blow Solenoid Poppet Valve

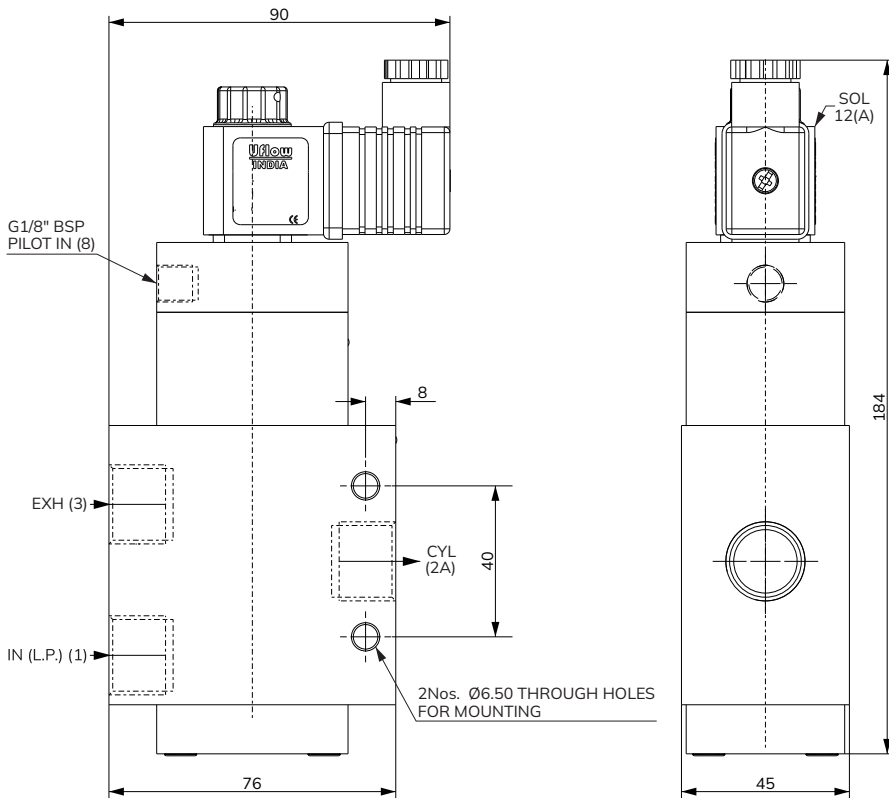

Diagram No. : 1.1



3/2 Dual Pressure Blow Solenoid Poppet Valve

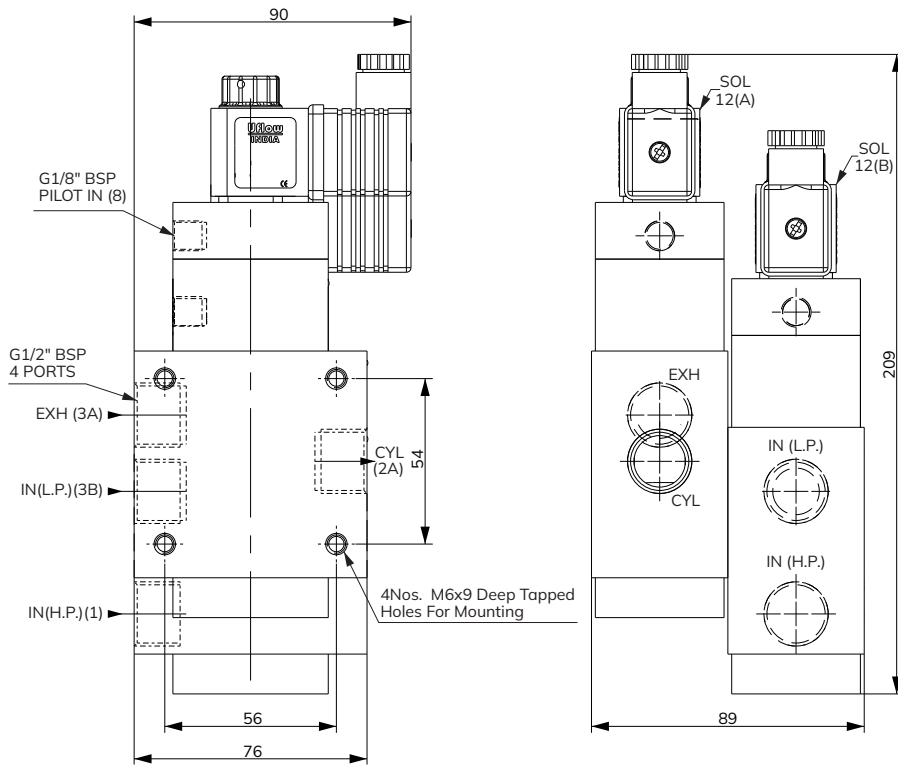

Diagram No. : 1.2



Sequence Of Operation

- SOL 12A 'ON' : Low Pressure (3B) is connected to outlet (Cyl 2A) (Low Pressure pre-blow)
- SOL 12A + SOL 12B 'ON' : High Pressure is connected to outlet (Cyl 2A) (High Pressure blow)
- Both SOL 'OFF' : Outlet (Cyl 2A) connected to Exh (3A) (Exhausting)

DCP - SERIES DC SOLENOID POPPET VALVE MODEL CHART

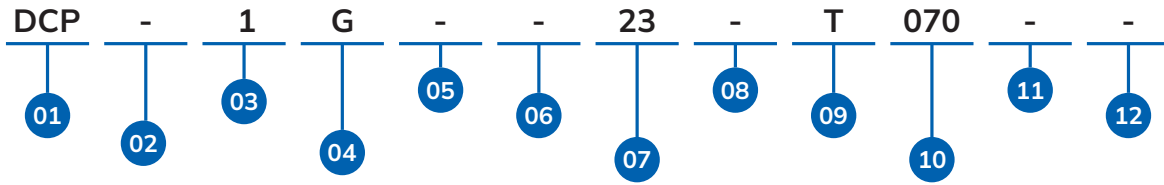

01	SERIES
-	DCP

02	PRODUCT TYPE
-	DC Poppet Valve
T	3 Way Direct Acting Poppet Valve

03	PORT SIZE & CONNECTION
7	3/8" BSP
7N	3/8" NPT
1	1/4" BSP
1N	1/4" NPT
2	1/2" BSP
2N	1/2" NPT
2P	1/2" BSPT
1R	1/4" Namur BSP
1T	1/4" Namur NPT

04	PORT POSITION & TYPE
A	3X2 NO Single Solenoid
B	3X2 NC Single Solenoid
F	3X2 Double Solenoid
G	5X2 Single Solenoid
H	5X2 Double Solenoid
J	3X2 & 5X2 Single Solenoid Convertible
U	3X2 Universal
L	4X2 Single Solenoid
M	4X2 Double Solenoid

05	BODY MATERIAL
-	Aluminium
4	SS304
6	SS316
L	SS316L
R	Brass Bar

06	SEAL MATERIAL
-	Nitrile
E	EPDM
V	Viton
S	Silicone
O	Fluoro Silicone
D	HNBR
J	VITON GLT

07	PRESSURE RANGE
-	0 - 10 Bar
23	2 - 10 Bar
24	2 - 20 Bar
25	3 - 40 Bar
29	1 - 3 Bar
40	3 - 20 Bar
56	3 - 10 Bar
58	3 - 13 Bar

08	COIL DIA
-	14MM
F	14MM FLP
I	18MM
W	18MM FLP
C	10MM
N	14MM SS FLP

09	FEATURES
-	W/O Mor
P	Push Mor
T	Push & Turn Mor
K	Lever Type
M	Turn Mor

10	ORIFICE IN MM
060	6MM Orifice
120	12MM Orifice
070	7MM Orifice
050	5MM Orifice
080	8MM Orifice
100	10MM Orifice
130	13MM Orifice
160	16MM Orifice

11	CONFIGURATION
-	REGULAR
C1	CONFIG 1
C2	CONFIG 2
C3	CONFIG 3
⋮	⋮
C9	CONFIG 9
CA	CONFIG 10
CB	CONFIG 11

12	VERSION
-	VERSION 0
V1	VERSION 1
V2	VERSION 2
V3	VERSION 3
⋮	⋮
V9	VERSION 9
VA	VERSION 10
VB	VERSION 11

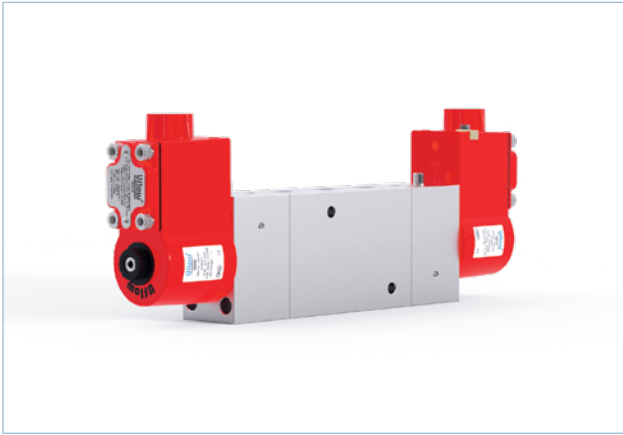

Valve Specifications

Type :	5x2
Design :	Internal Pilot Operated Poppet Valve
Port Size :	In / Out / Exhaust - ½" BSP (Available in NPT)
Media :	Compressed Air (Filtered & Lubricated)
working Pressure Range :	2-10 Bar
Orifice :	12 mm
Flow Factor :	50 kv (LPM of Water @ 1 bar ΔP)
Ambient / Media Temperature :	5°C - 60°C
Materials of Construction :	SS316, Nitrile, Polymer

Coil Specification

Operating Voltage :	24V AC	110V AC	230V AC	24V DC
Power Consumption :	9W	9W	9W	11W
Coil Features :	High Reliability Unaffected by Voltage Surges. Easy coil changes coil lockable in 4X90 position or freely movable in between as require.			
Coil Housing :	IP67 Flameproof Junction box			

Port Connection

1 - Input, 2/4 - Output, 3/5 - Exhaust

Valve Model No.	Function	Symbol
DCI-2H6F120	Double Solenoid	

Features

- Fast response time 1000 cycle/min
- Manual override
- 20 Million cycle tested
- Lubrication not essential
- Suitable for high speed cycling
- Life > 20 Million Cycle

Dimension Drawing (All dimensions in mm)

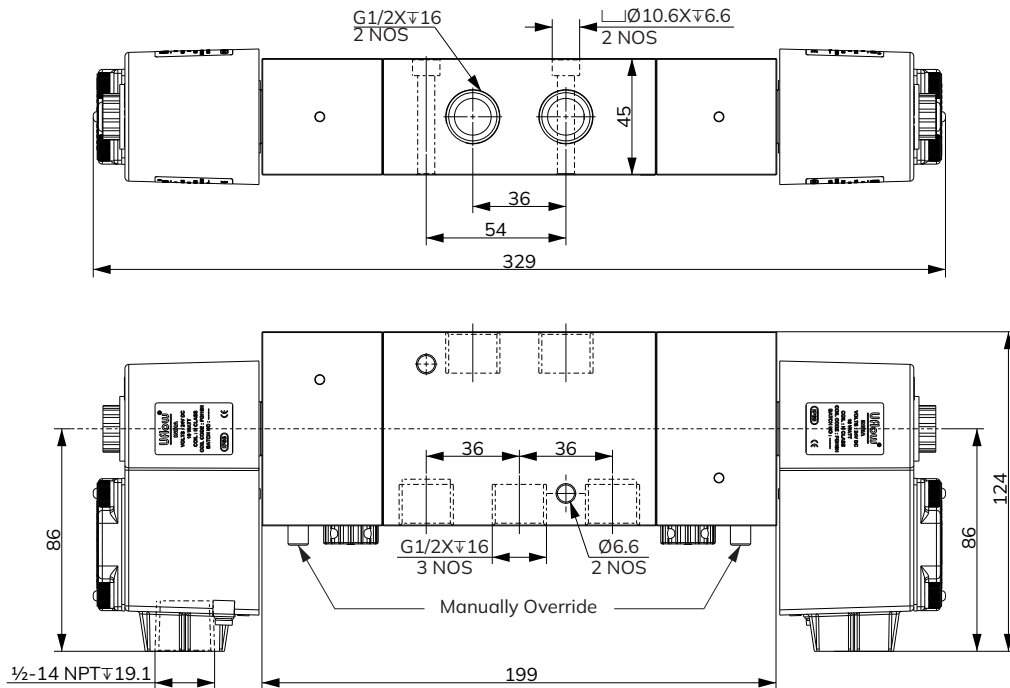

DCI - SERIES DC SOLENOID INTEGRATED TYPE POPPET VALVE MODEL CHART

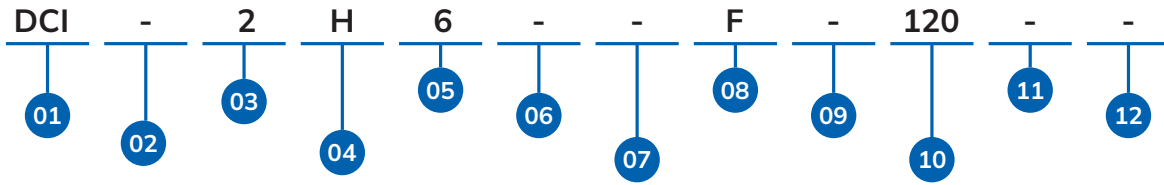

01	SERIES
	DCI

02	PRODUCT TYPE
-	Integrated Type Poppet Valve

03	PORT SIZE & CONNECTION
1	1/4" BSP
1N	1/4" NPT
1P	1/4" BSPT
1R	1/4" Namur BSP
1T	1/4" Namur NPT
2	1/2" BSP
2N	1/2" NPT
2P	1/2" BSPT
2R	1/2" Namur BSP
2T	1/2" Namur NPT

04	PORT POSITION & TYPE
A	3X2 NO Single Solenoid
B	3X2 NC Single Solenoid
F	3X2 Double Solenoid
G	5X2 Single Solenoid
H	5X2 Double Solenoid
J	3X2 & 5X2 Single Solenoid Convertible
K	3X2 & 5X2 Double Solenoid Convertible

05	BODY MATERIAL
-	ALU
4	SS304
6	SS316

06	SEAL MATERIAL
-	Nitrile
V	VITON
S	Silicone
C	Fluoro Silicone

07	PRESSURE RANGE
-	2-10 Bar

08	COIL DIA
-	14MM
F	14MM FLP

09	FEATURES
-	Push MOR
T	Push & Turn Mor

10	ORIFICE IN MM
060	6MM Orifice
120	12MM Orifice

11	CONFIGURATION
-	REGULAR
C1	CONFIG 1
C2	CONFIG 2
C3	CONFIG 3
⋮	⋮
C9	CONFIG 9
CA	CONFIG 10
CB	CONFIG 11

12	VERSION
-	VERSION 0
V1	VERSION 1
V2	VERSION 2
V3	VERSION 3
⋮	⋮
V9	VERSION 9
VA	VERSION 10
VB	VERSION 11

DCI-2H6F120
1/2" BSP INTEGRATED TYPE POPPET VALVE 5X2 DOUBLE SOLENOID SS316-NITRILE-2 TO 10 BAR-14MM FLP-PUSH MOR-12MM ORIFICE



Diagram No.1

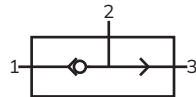
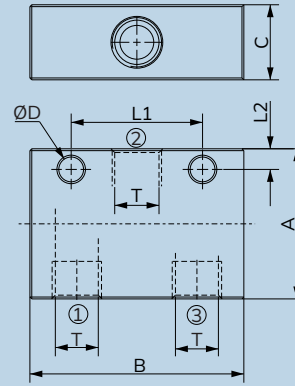

Specifications

Model No:	M5	1/8	1/4
Medium:	Compressed air - Dry, Filtered, Lubricated		
Operating pressure range :	1.5 TO 10 bar		
Ambient temperature :	-10 to +60°C		
Medium temperature :	+5 to +50°C		
Flow * (1→2) (3→2) :	120 LPM	250 LPM	620 LPM
Materials of Construction :	Aluminium, Nitrile, Plastic		

*Inlet pressure 6 bar, and pressure drop 1 bar

Function

- OR valve delivers air at the outlet (2) always supplied by higher pressure (1 or 3).
- If two signals of different pressure is applied, the higher pressure is connected to outlet (2).

Application

- An OR valve, or shuttle valve, ensures that a function can be activated from one of two different inputs. It provides an output signal as long as at least one input signal is present. This makes it ideal for use in safety circuits and logic-based operations.

Technical Data

Model No.	T	A	B	C	L1	L2	L3	ØD
SH-R1	M5	25	37	15	10	3.5	20	3.2
SH-R2	G1/8	30	43	15	24	4	24	4.5
SH-R3	G1/4	40	57	20	35	5.5	32	6.6



Diagram No.1

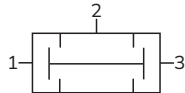
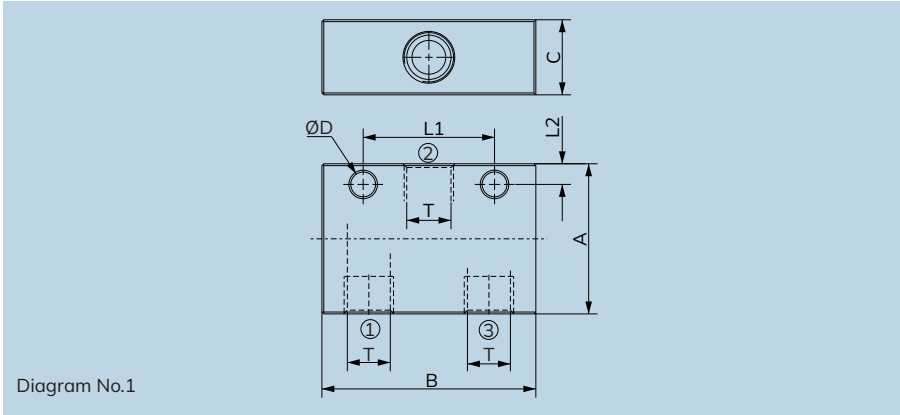

Specifications

Model No:	M5	1/8	1/4
Medium:	Compressed air - Dry, Filtered, Lubricated		
Operating pressure range :	1.5 TO 10 bar		
Ambient temperature :	-10 to +60°C		
Media temperature :	+5 to +55°C		
Flow * (1→2) (3→2) :	120 LPM	250 LPM	620 LPM
Materials of Construction :	Aluminium, Nitrile, Brass, Plastic,SS		

*Inlet pressure 6 bar, and pressure drop 1 bar

Function

- AND valve delivers air at the outlet (2) only when air signal is present at both inputs (1 or 3).
- If two signals of different pressure is applied, the lower pressure is connected to outlet (2).

Application

- An AND valve (dual pressure valve) is designed to activate a function only when at least two input signals are present. It is widely utilized in safety systems and logic controls.

Technical Data

Model No.	T	A	B	C	L1	L2	L3	ØD
SH-A1	M5	25	37	15	10	3.5	20	3.2
SH-A2	G1/8	30	43	15	24	4	24	4.5
SH-A3	G1/4	40	57	20	35	5.5	32	6.6

SH - SERIES SHUTTLE VALVE MODEL CHART

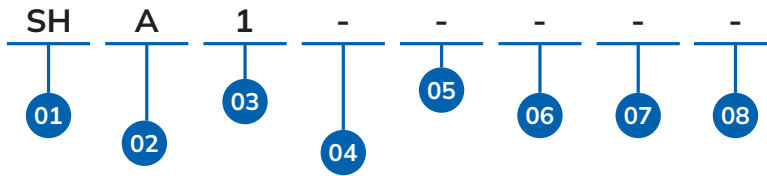

01	SERIES
	SH

02	PRODUCT TYPE
A	AND VALVE
R	OR VALVE

03	PORT POSITION & CONNECTION
1	1/4"
2	1/8"
3	M5

04	BODY MATERIAL
-	Aluminium

05	SEAL MATERIAL
-	NITRILE

06	PRESSURE RANGE
-	1.5 TO 10 Bar

07	CONFIGURATION
-	REGULAR
C1	CONFIG 1
C2	CONFIG 2
C3	CONFIG 3
⋮	⋮
C9	CONFIG 9
CA	CONFIG 10
CB	CONFIG 12

08	VERSION
-	VERSION 0
V1	VERSION 1
V2	VERSION 2
V3	VERSION 3
⋮	⋮
V9	VERSION 9
VA	VERSION 10
VB	VERSION 11

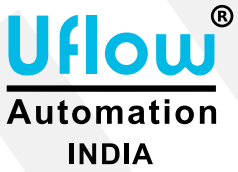

SH-A1
1/4" AND VALVE-ALUMINIUM-NITRILE-1.5 TO 10 BAR



**SOLENOID VALVE
SERIES**

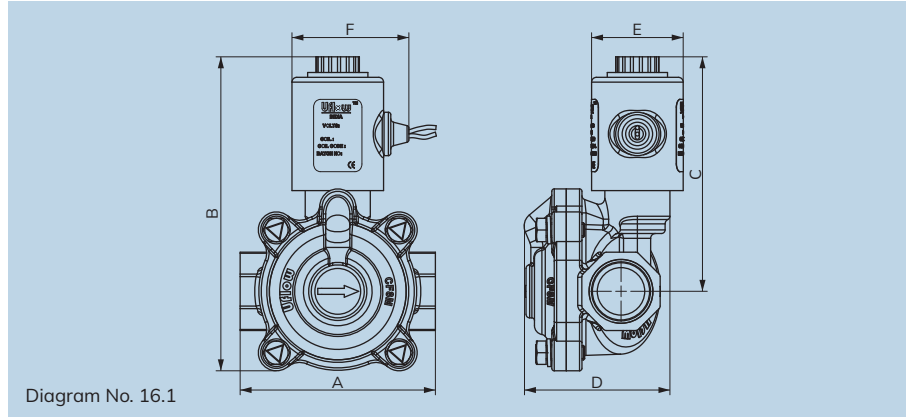
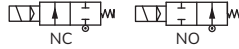

Diagram No. 16.1



Specifications

Port :	3/8", 1/2", 3/4", 1", 1 1/4", 1 1/2", 2", 2 1/2", 3" & 4" (Available BSP / NPT)				
End Connection :	Screwed / Flange				
Body Material :	SS ASTM A351 Grade CF8 / CF8M				
Diaphragm :	Nitrile (NBR)	EPDM	Viton (FKM)		
Media Temp :	-30°C to 90°C	-10°C to 140°C	-10°C to 180°C		
Circumstance Temp :	-10°C to 70°C				
Media :	Air, Water, Chemical, Gas, Oil & LPG				
Main Features :	Internal Parts are in superior corrosion resistance steel, (Equivalent to SS316L) Suitable for Food Industries, Pharmaceuticals, Chemical application & Highly corrosive environment.				
Operating Voltage :	24AC	110AC	230AC	12DC	24DC
Power Consumption :	9W	9W	9W	10W	11W
Coil Features :	High Reliability Unaffected by Voltage Surges. Easy coil changes coil lockable in 4X90 position or freely movable in between as require.				
Coil Housing :	IP65 Epoxy square coil, IP65 Metallic round enclosure, IP67 Flameproof enclosure, IP68 Weatherproof enclosure.				
Optional Feature :	90% Power saver series also available, Manual Override, Water hammering reducer also available to avoid water hammer forces.				
Other Specification Data :	Available on Request. - High Pressure 20Kg Series. - Manual Override				

NOTE: Use of filter in the inlet port is recommended.

Dimension - NC (All dimensions in mm)

All dimensions are approx.

Model No.	Port Size	Diagram No.	A	B	C	D	E	F
PCN-7E	3/8"	16.1	67	123	95	52	38	49
PCN-2E	1/2"	16.1	67	123	95	52	38	49
PCN-3E	3/4"	16.1	81	130	97	60	38	49
PCN-4E	1"	16.1	96	146	105	66	38	49
PCN-5E	1 1/4"	16.1	108	154	108	88	38	49
PCN-6E	1 1/2"	16.1	108	154	108	88	38	49
PCN-8E	2"	16.1	132	181	126	102	38	49
PCN-9E	2 1/2"	16.1	166	212	140	126	38	49
PCN-AE	3"	16.1	192	237	151	138	38	49
PCN-BI	4"	16.1	262	257	194	202	50	63

In normally open valve dimension B&C will increase up to 8mm.

Section View



Technical Data

Model No.	Body Material	Pipe (Inch)	Orifice (mm)	Min. Operating Pressure Kg/cm ²	Max. Operating Pressure Kg/cm ²	Seal & Diaphragm Material	Flow Factor Kv m ³ / hr
PCN-7E	CF8 / CF8M	3/8"	15	0.5	12	NBR / EPDM / VITON	2
PCN-2E	CF8 / CF8M	1/2"	17	0.5	12	NBR / EPDM / VITON	4.4
PCN-3E	CF8 / CF8M	3/4"	20	0.5	12	NBR / EPDM / VITON	3.7
PCN-4E	CF8 / CF8M	1"	25	0.5	12	NBR / EPDM / VITON	10
PCN-5E	CF8 / CF8M	1 1/4"	36	0.5	12	NBR / EPDM / VITON	12.2
PCN-6E	CF8 / CF8M	1 1/2"	36	0.5	12	NBR / EPDM / VITON	17.1
PCN-8E	CF8 / CF8M	2"	47	0.5	12	NBR / EPDM / VITON	33.3
PCN-9E	CF8 / CF8M	2 1/2"	59	0.5	12	NBR / EPDM / VITON	43.5
PCN-AE	CF8 / CF8M	3"	71	0.5	12	NBR / EPDM / VITON	64.5
PCN-BI	CF8 / CF8M	4"	98	0.5	12	NBR / EPDM / VITON	115

PCN -SERIES PILOT OPERATED DIAPHRAGM TYPE SOLENOID VALVE MODEL CHART

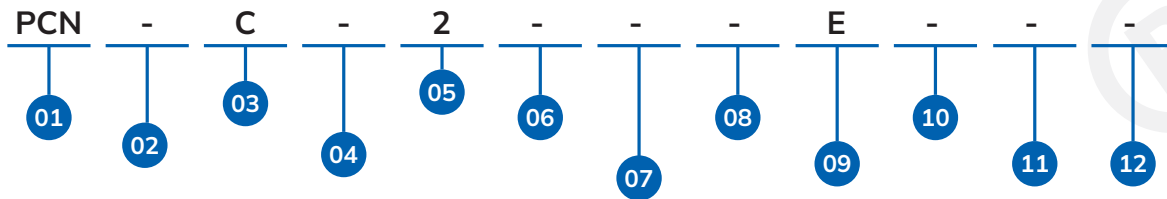

01	SERIES
PCN	

02	PRODUCT TYPE
-	Pilot Operated Diaphragm
F	Fast Acting

03	BODY MATERIAL
-	CF8
M	CF8M
C	CF3M

04	SEAL MATERIAL
-	NITRILE
E	EPDM
V	VITON
N	BUNA N

05	PORT SIZE
2	1/2"
3	3/4"
4	1"
5	1-1/4"
6	1-1/2"
7	3/8"
8	2"
9	2-1/2"
A	3"
B	4"

06	PRESSURE RANGE
-	0.5 - 12 Bar
16	1 - 20 Bar

07	PORT CONNECTION
-	BSP
N	NPT
P	BSPT
D	Flange End
L	Flat Face Flange End
T	Tri Clover End

08	VALVE POSITION
-	NC
Z	NO

09	COIL DIA
E	14mm AC
F	14mm DC
G	14mm FLP AC
H	14mm FLP DC
I	18mm AC
J	18mm DC
V	18m FLP AC
W	18mm FLP DC
5	14mm SS FLP AC
6	14mm SS FLP DC
7	14mm Bottom Cable Entry Exp. AC
7D	14mm Bottom Cable Entry Exp. AC
8	14mm Bottom Cable Entry Exp. AC
8D	18mm Bottom Cable Entry Exp. DC

10	FEATURES
-	W/O MOR
M	TURN MOR

11	CONFIGURATION
-	REGULAR
C1	CONFIG 1
C2	CONFIG 2
C3	CONFIG 3
⋮	⋮
C9	CONFIG 9
CA	CONFIG 10
CB	CONFIG 11

12	VERSION
-	VERSION 0
V1	VERSION 1
V2	VERSION 2
V3	VERSION 3
⋮	⋮
V9	VERSION 9
VA	VERSION 10
VB	VERSION 11

PCN-C2E
1/2" PILOT OPERATED DIAPHRAGM CF3M-NITRILE-
0.5 TO 12 Bar-BSP-NC-14MM AC

Note : The above chart is for identification purposes only, and it may not be possible to make all combinations for the above chart.

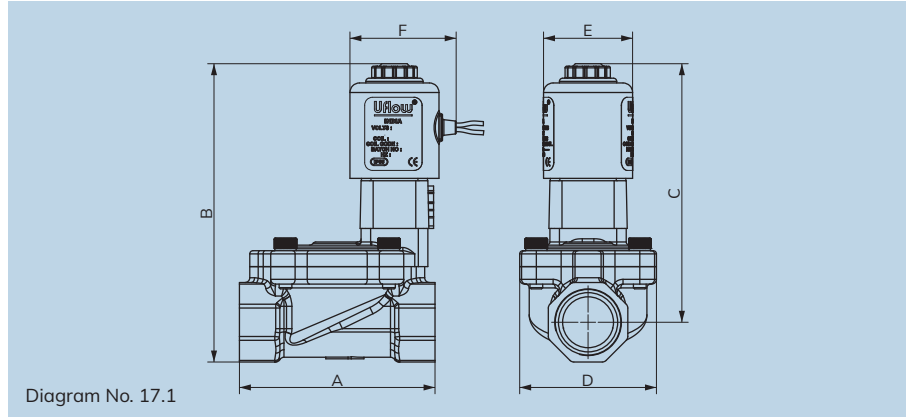
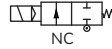

Diagram No. 17.1



Specifications

Port :	3/8", 1/2", 3/4", 1", 1 1/2" & 2" (Available BSP / NPT)				
End Connection :	Screwed				
Body Material :	Forged Brass				
Diaphragm :	Nitrile (NBR)	EPDM	Viton (FKM)		
Media Temp :	-30°C to 90°C	-10°C to 140°C	-10°C to 180°C		
Circumstance Temp :	-10°C to 70°C				
Media :	Air, Water, Chemical, Gas, Oil, Diesel, Kerosene, LPG.				
Main Features :	Internal Parts are in superior corrosion resistance steel, (Equivalent to SS316L) Suitable for Food Industries, Pharmaceuticals, Chemical application & Highly corrosive environment.				
Operating Voltage :	24AC	110AC	230AC	12DC	24DC
Power Consumption :	9W / 6W	9W / 6W	9W / 6W	10W / 6W	11W / 6W
Coil Features :	High Reliability Unaffected by Voltage Surges. Easy coil changes coil lockable in 4X90 position or freely movable in between as require.				
Coil Housing :	IP65 Epoxy square coil, IP65 Metallic round enclosure, IP68 Weatherproof enclosure.				
Optional Feature :	90% Power saver series also available, Manual Override, Water hammering reducer also available to avoid water hammer forces.				
Other Specification Data :	Available on Request.				

NOTE: Use of filter in the inlet port is recommended.

Technical Data

Model No.	Body Material	Pipe (Inch)	Orifice (mm)	Min. Operating Pressure Kg/cm ²	Max. Operating Pressure Kg/cm ²	Seal & Diaphragm Material	Flow Factor Kv m ³ / hr
PBN-7CM	BRASS	3/8"	16	0.5	10	NBR / EPDM / VITON	1.5
PBN-2CM	BRASS	1/2"	16	0.5	10	NBR / EPDM / VITON	2.1
PBN-3CM	BRASS	3/4"	20	0.5	10	NBR / EPDM / VITON	5.5
PBN-4CM	BRASS	1"	25	0.5	10	NBR / EPDM / VITON	9
PBN-5CM	BRASS	1 1/4"	36	0.5	10	NBR / EPDM / VITON	17.1
PBN-6CM	BRASS	1 1/2"	36	0.5	10	NBR / EPDM / VITON	17.1
PBN-8EM	BRASS	2"	50	0.5	10	NBR / EPDM / VITON	29.9

Dimension - NC (All dimensions in mm)

All Dimensions are approx.

Model No.	Port Size	Diagram No.	A	B	C	D	E	F
PBN-7CM	3/8"	17.1	62	97	85	43	28	33
PBN-2CM	1/2"	17.1	62	97	85	43	28	33
PBN-3CM	3/4"	17.1	77	101	85	52	28	33
PBN-4CM	1"	17.1	92	109	89	63	28	33
PBN-5CM	1 1/4"	17.1	120	123	95	81	28	33
PBN-6CM	1 1/2"	17.1	120	123	95	81	28	33
PBN-8EM	2"	17.1	145	153	120	106	38	48

Section View

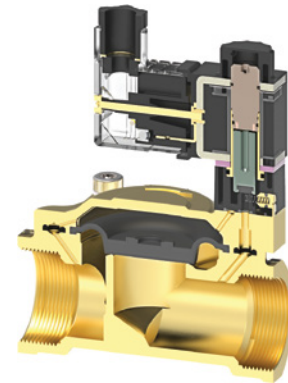

PBN -SERIES PILOT OPERATED SOLENOID VALVE MODEL CHART

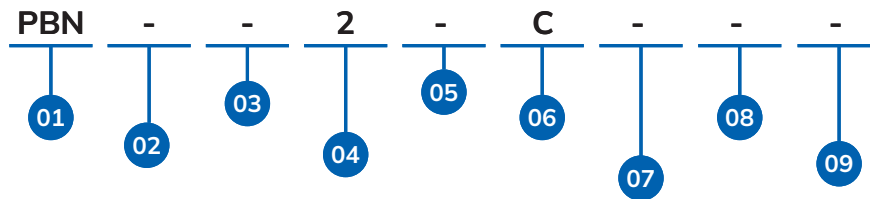

01	SERIES
PBN	

02	PRODUCT TYPE
-	Pilot Operated Diaphragm

03	SEAL MATERIAL
-	NITRILE
E	EPDM
V	VITON

04	PORT SIZE
2	1/2"
3	3/4"
4	1"
5	1-1/4"
6	1-1/2"
7	3/8"
8	2"

05	PORT CONNECTION
-	BSP
N	NPT
P	BSPT

06	COIL DIA
C	10mm AC
D	10mm DC
E	14mm AC
F	14mm DC
G	14mm FLP AC
H	14mm FLP DC
5	14mm SS FLP AC
6	14mm SS FLP DC
7	14mm Bottom Cable Entry Exp. AC
7D	14mm Bottom Cable Entry Exp. AC
8	14mm Bottom Cable Entry Exp. AC
8D	14mm Bottom Cable Entry Exp. AC

07	FEATURES
-	W/O MOR
M	TURN MOR

08	CONFIGURATION
-	REGULAR
C1	CONFIG 1
C2	CONFIG 2
C3	CONFIG 3
⋮	⋮
C9	CONFIG 9
CA	CONFIG 10
CB	CONFIG 11

09	VERSION
-	VERSION 0
V1	VERSION 1
V2	VERSION 2
V3	VERSION 3
⋮	⋮
V9	VERSION 9
VA	VERSION 10
VB	VERSION 11

PBN-2C
1/2" PILOT OPERATED DIAPHRAGM BRASS FORGE-NITRILE-
0.5 TO 10 BAR-BSP-NC-10MM AC

Note : The above chart is for identification purposes only, and it may not be possible to make all combinations for the above chart.

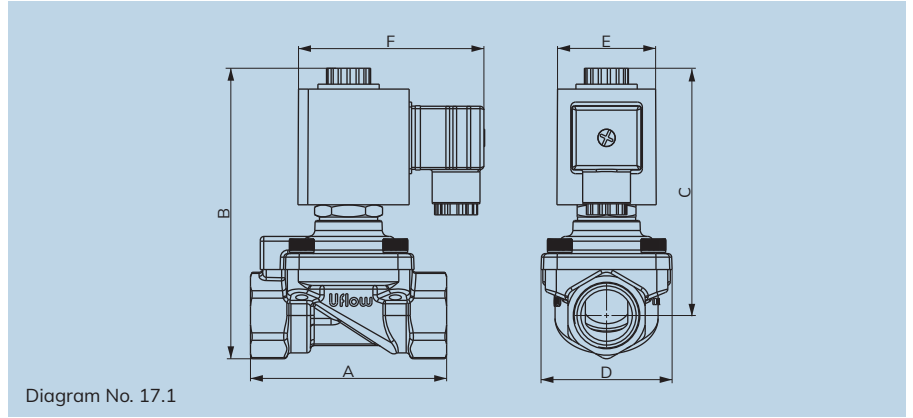
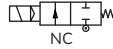

Diagram No. 17.1



Specifications

Port :	3/8" & 1/2" (Available BSP / NPT)		
End Connection :	Screwed		
Body Material :	Forged Brass		
Diaphragm :	PUR		
Media Temp :	-10°C to 50°C		
Circumstance Temp :	-10°C to 70°C		
Media :	Air		
Main Features :	Internal Parts are in superior corrosion resistance steel, (Equivalent to SS316L) Suitable for Food Industries, Pharmaceuticals, Chemical application & Highly corrosive environment.		
Operating Voltage :	230AC	12DC	24DC
Power Consumption :	9W / 6W	10W / 6W	11W / 6W
Coil Features :	High Reliability Unaffected by Voltage Surges. Easy coil changes coil lockable in 4X90 position or freely movable in between as require.		
Coil Housing :	IP65 Epoxy square coil		
Other Specification Data :	Available on Request.		

NOTE: Use of filter in the inlet port is recommended.

Technical Data

Model No.	Body Material	Pipe (Inch)	Orifice (mm)	Min. Operating Pressure Kg/cm ²	Max. Operating Pressure Kg/cm ²	Seal & Diaphragm Material	Flow Factor Qn l/min
PBU-2Y	BRASS	1/2"	15	1.5	40	PUR	3550
PBU-3Y	BRASS	3/4"	15	1.5	40	PUR	3550

Dimension - NC (All dimensions in mm)

All Dimensions are approx.

Model No.	Port Size	Diagram No.	A	B	C	D	E	F
PBN-U2Y	1/2"	17.1	80	119	101	54	40	76
PBN-UY	3/4"	17.1	80	119	101	54	40	76

Features

- Fast Response Time.
- PUR Diaphragm.
- High Pressure.
- Minimal Disruption of Response Time.
- Inbuilt Filter.
- Higher Service Life.
- Minimal Disruption of Response Time.

Application

- High Switching Cycle.
- Blow Molding Equipment.

PBU - SERIES PILOT OPERATED DIAPHRAGM SOLENOID VALVE MODEL CHART

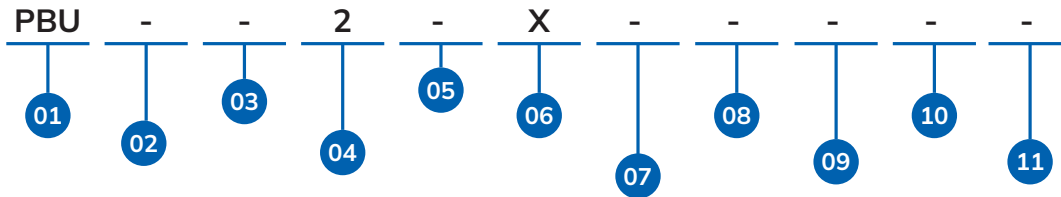

01	SERIES
PBU	

02	PRODUCT TYPE
-	Pilot Operated Diaphragm

03	BODY MATERIAL
-	BRASS
C	CF8
M	CF8M

04	SEAL MATERIAL
-	PUR
E	EPDM
V	Viton
N	Nitrile

05	PORT SIZE
2	1/2"
3	3/4"

06	PRESSURE
-	1.5 TO 40 Bar

07	PORT CONNECTION
-	BSP
N	NPT
P	BSPT

08	VALVE POSITION
-	NC
Z	NO

09	COIL DIA
X	16mm AC
Y	16mm DC
7	14mm Bottom Cable Entry Exp. AC
7D	14mm Bottom Cable Entry Exp. AC
8	14mm Bottom Cable Entry Exp. AC
8D	14mm Bottom Cable Entry Exp. AC

10	CONFIGURATION
-	REGULAR
C1	CONFIG 1
C2	CONFIG 2
C3	CONFIG 3
⋮	⋮
C9	CONFIG 9
CA	CONFIG 10
CB	CONFIG 11

11	VERSION
-	VERSION 0
V1	VERSION 1
V2	VERSION 2
V3	VERSION 3
⋮	⋮
V9	VERSION 9
VA	VERSION 10
VB	VERSION 11

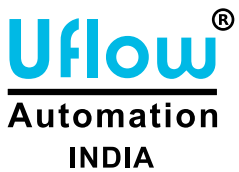

PBU-2X
 1/2" PILOT OPERATED DIAPHRAGM BRASS-PUR
 -1.5 TO 40 Bar-BSP-NC-16MM AC

Note: The above chart is for identification purposes only, and it may not be possible to make all combinations for the above chart.

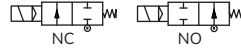
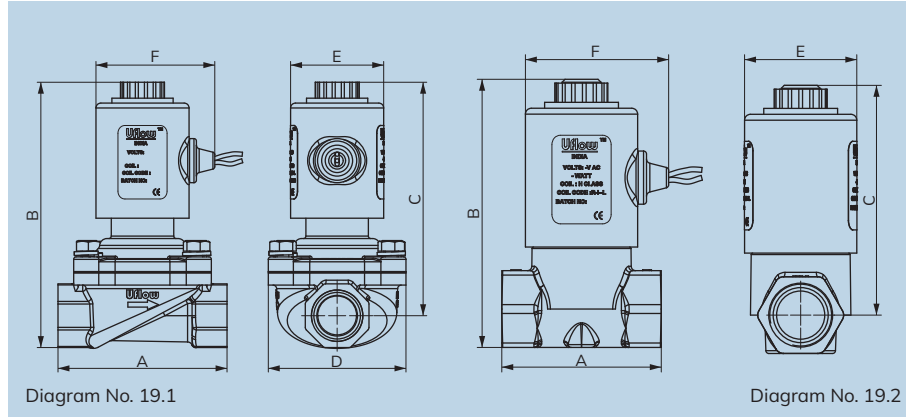
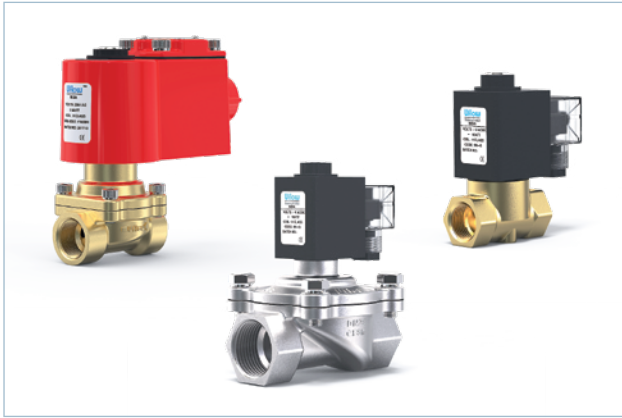

Specifications

Port :	3/8", 1/2", 3/4", 1", 1 1/2" & 2" (Available BSP / NPT)				
End Connection :	Screwed / Flange				
Body Material :	SS ASTM A351 Grade CF8 / CF8M, Forged Brass				
Diaphragm :	Nitrile (NBR)	EPDM	Viton (FKM)	PTFE	
Media Temp :	-30°C to 90°C	-10°C to 140°C	-10°C to 180°C	-10°C to 180°C	
Circumstance Temp :	-10°C to 70°C				
Media :	Air, Water, Chemical, Gas, Oil, Steam, LPG.				
Main Features :	Internal Parts are in superior corrosion resistance steel, (Equivalent to SS316L) Suitable for Food Industries, Pharmaceuticals, Chemical application & Highly corrosive environment.				
Operating Voltage :	24AC	110AC	230AC	12DC	24DC
Power Consumption :	9W	9W	9W	10W	11W
Coil Features :	High Reliability Unaffected by Voltage Surges. Easy coil changes coil lockable in 4X90 position or freely movable in between as require.				
Coil Housing :	IP65 Epoxy square coil, IP65 Metallic round enclosure, IP67 Flameproof enclosure, IP68 Weatherproof enclosure.				
Optional Feature :	90% Power saver series also available, Water hammering reducer also available to avoid water hammer forces. Special high flow rate series available on request at low pressure or gravity pressure application.				

Note : Use of filter in the inlet port is recommended., Preferably Over Horizontal Pipeline with the coil upright.
Caution : AC coil should not be used on a DC coil valve.

Technical Data

Model No.	Body Material	Pipe (Inch)	Orifice (mm)	Min. Operating Pressure Kg/cm ²	Max. Operating Pressure Kg/cm ²	Seal & Diaphragm Material	Flow Factor Kv m ³ / hr
MCN-B703E	BRASS	3/8"	15.5	0	7	NBR / EPDM / VITON	2.5
MCN-B704E	BRASS	3/8"	12	0	10	NBR / EPDM / VITON	2.5
MCN-B203E	BRASS	1/2"	15.5	0	7	NBR / EPDM / VITON	3.1
MCN-B204E	BRASS	1/2"	12	0	10	NBR / EPDM / VITON	2.3
MCN-204E	CF8 / CF8M	1/2"	15	0	10	NBR / EPDM / VITON	2.5
MCN-203E	CF8 / CF8M	1/2"	17	0	7	NBR / EPDM / VITON	3.2
MCN-303E	CF8 / CF8M	3/4"	20	0	7	NBR / EPDM / VITON	5
MCN-304E	CF8 / CF8M	3/4"	18	0	10	NBR / EPDM / VITON	2.1
MCN-403E	CF8 / CF8M	1"	25.5	0	7	NBR / EPDM / VITON	8.2
MCN-613I	CF8 / CF8M	1 1/2"	38	0	4	NBR / EPDM / VITON	18.2
MCN-813I	CF8 / CF8M	2"	46.5	0	4	NBR / EPDM / VITON	31.4

Dimension - NC (All dimensions in mm)

All Dimensions are approx.

Model No.	Port Size	Diagram No.	A	B	C	D	E	F
MCN-B703E	3/8"	19.1	57	107	93	46	38	49
MCN-B203E	1/2"	19.1	57	107	93	46	38	49
MCN-B204E	1/2"	19.2	54	94	80	-	38	49
MCN-203E	1/2"	19.1	69	109	95	56	38	49
MCN-303E	3/4"	19.1	76	114	98	62	38	49
MCN-304E	3/4"	19.2	65	101	85	-	38	49
MCN-403E	1"	19.1	100	122	102	78	38	49
MCN-613I	1 1/2"	19.1	108	151	124	89	50	62
MCN-813I	2"	19.1	130	170	137	107	50	62

In normally open valve dimension B&C will increase up to 8mm.

Section View

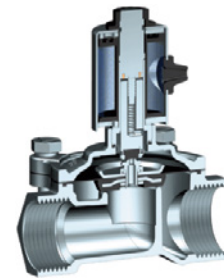

MCN - SERIES SEMI LIFT DIAPHRAGM OPERATED SOLENOID VALVE MODEL CHART

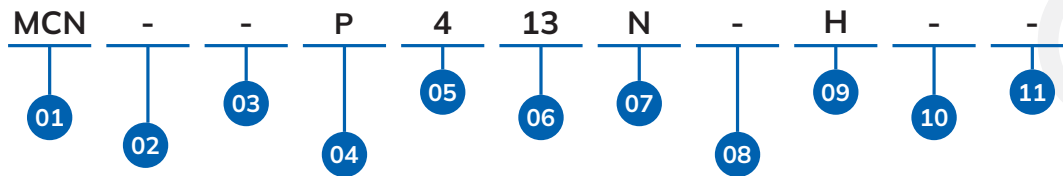

01	SERIES
MCN	

02	PRODUCT TYPE
-	Semi Lift Diaphragm Operated

03	BODY MATERIAL
-	CF8
M	CF8M
B	Brass Forge
C	CF3M

04	SEAL MATERIAL
-	NITRILE
E	EPDM
V	VITON
F	SPL. VITON
P	PTFE

05	PORT SIZE
2	1/2"
3	3/4"
4	1"
6	1-1/2"
7	3/8"
8	2"

06	PRESSURE RANGE
01	0 - 500 Mbar
02	0 - 2 Bar
03	0 - 7 Bar
04	0 - 10 Bar
13	0 - 4 Bar
14	0 - 3 Bar
15	0 - 1 Bar
19	0 - 5 Bar
52	-1 to 1 Bar

07	PORT CONNECTION
-	BSP
N	NPT
D	Flange End
P	BSPT
T	Tri Clover End

08	VALVE POSITION
-	NC
Z	NO

09	COIL DIA
E	14mm AC
F	14mm DC
G	14mmFLP AC
H	14mm FLP DC
I	18mm AC
J	18mm DC
V	18mm FLP AC
W	18mmFLP DC
5	14mm SS FLP AC
6	14mm SS FLP DC
7	14mm Bottom Cable Entry Exp. AC
7D	14mm Bottom Cable Entry Exp. AC
8	18mm Bottom Cable Entry Exp.AC
8D	18mm Bottom Cable Entry Exp.AC

10	CONFIG
-	REGULAR
C1	CONFIG 1
C2	CONFIG 2
C3	CONFIG 3
...	...
C9	CONFIG 9
CA	CONFIG 10
CB	CONFIG 11

11	VERSION
-	VERSION 0
V1	VERSION 1
V2	VERSION 2
V3	VERSION 3
...	...
V9	VERSION 9
VA	VERSION 10
VB	VERSION 11

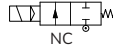
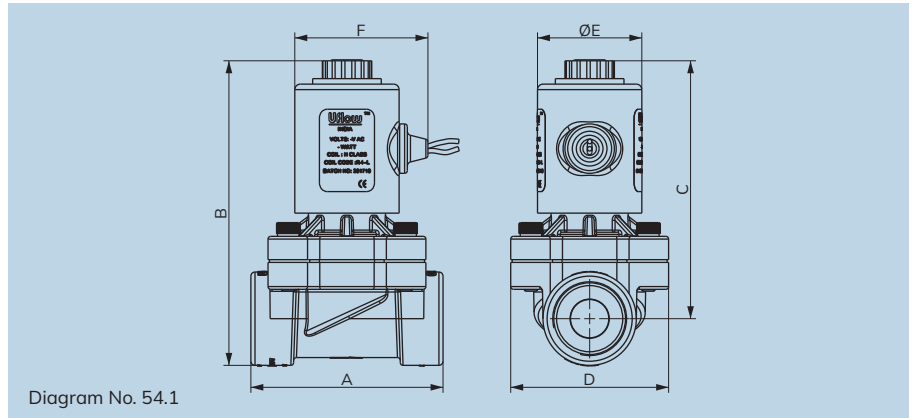

Specifications

Port :	½", ¾" & 1" (Available in BSP / BSPT / NPT)			
End Connection :	Screwed			
Body Material :	Nylon Glass Filled			
Diaphragm :	Nitrile (NBR)			
Media Temp. :	5°C to 50°C			
Circumstance Temp. :	-10°C to 50°C			
Media :	Water, Air, Inert Gas			
Main Features :	Internal Parts are in superior corrosion resistance steel, (Equivalent to SS316L) Suitable for Food Industries, Pharmaceuticals, Chemical application & Highly corrosive environment.			
Operating Voltage :	110AC	230AC	12DC	24DC
Power Consumption :	11W	10W	10W	11W
Coil Features :	High Reliability Unaffected by Voltage Surges. Easy coil changes coil lockable in 4X90 position or freely movable in between as require.			
Coil Housing :	IP65 Epoxy square coil, IP65 Metallic round enclosure, IP68 Weatherproof enclosure.			
Other Specification Data :	Available on Request			

NOTE: Use of filter in the inlet port is recommended.

Technical Data

Model No.	Body Material	Pipe (Inch)	Orifice (mm)	Min. Operating Pressure mbar	Max. Operating Pressure bar	Seal & Diaphragm Material	Flow Factor Kv m ³ / hr
MNN-2E	Nylon GF	½"	16	0	7	NBR	2.1
MNN-3E	Nylon GF	¾"	16	0	7	NBR	3
MNN-413E	Nylon GF	1"	26	0	4	NBR	8.2

Dimension (All dimensions are in mm)

All Dimensions are approx.

Model No.	Port Size	Diagram No.	A	B	C	D	ØE	F
MNN-2E	½"	54.1	70	110	94	58	44	57
MNN-3E	¾"	54.1	70	110	94	58	44	57
MNN-413E	1"	54.1	107	122	101	77	44	57

Section View

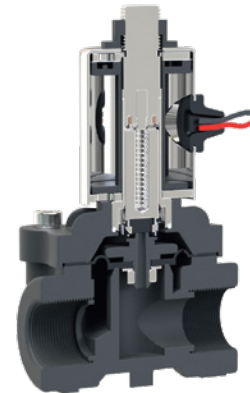

MNN - SERIES SEMI LIFT DIAPHRAGM OPERATED SOLENOID PLASTIC VALVE MODEL CHART

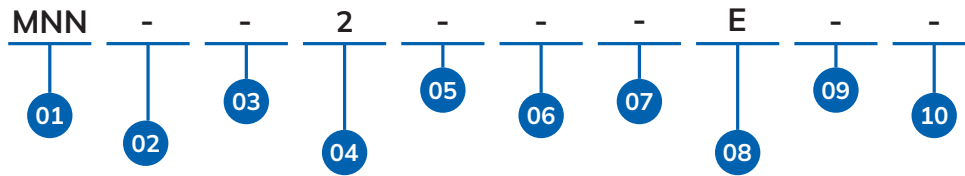

01	SERIES
MNN	

02	PRODUCT TYPE
-	Semi Lift Diaphragm Operated

03	SEAL MATERIAL
-	Nitrile
E	EPDM

04	PORT SIZE
2	1/2"
3	3/4"
4	1"

05	PRESSURE RANGE
-	0 - 7 Bar
13	0 - 4 Bar

06	PORT CONNECTION
-	BSP
N	NPT
P	BSPT

07	VALVE POSITION
-	NC

08	COIL DIA
E	14mm AC
F	14mm DC
G	14mm FLP AC
H	14mm FLP DC
5	14mm SS FLP AC
6	14mm SS FLP DC
7	14mm Bottom Cable Entry Exp. AC
7D	14mm Bottom Cable Entry Exp. AC
8	18mm Bottom Cable Entry Exp.AC
8D	18mm Bottom Cable Entry Exp. DC

09	CONFIGURATION
-	Regular
C1	CONFIG 1
C2	CONFIG 2
C3	CONFIG 3
⋮	⋮
C9	CONFIG 9
CA	CONFIG 10
CB	CONFIG 11

10	VERSION
-	VERSION 0
V1	VERSION 1
V2	VERSION 2
V3	VERSION 3
⋮	⋮
V9	VERSION 9
VA	VERSION 10
VB	VERSION 11

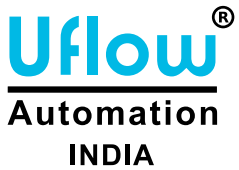

MNN-2E
 1/2" SEMI LIFT DIAPHRAGM OPERATED NYLON GF-NITRILE-0 TO 7 BAR-BSP-NC-14MM AC

Note: The above chart is for identification purposes only, and it may not be possible to make all combinations for the above chart.

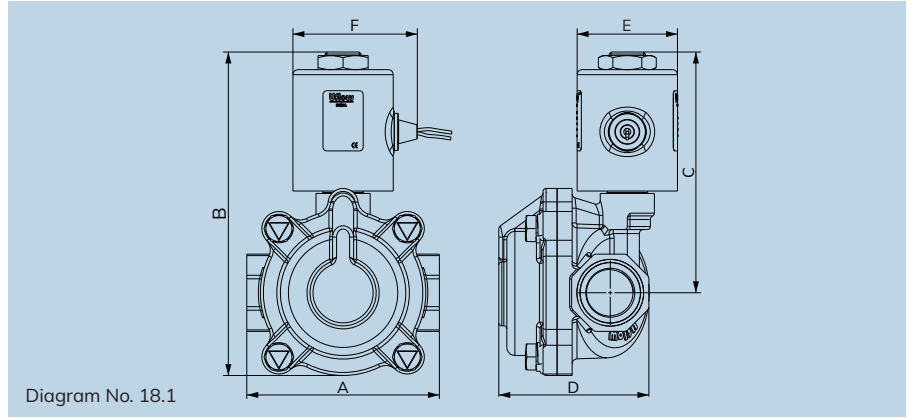
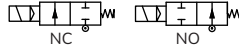

Diagram No. 18.1



Specifications

Port :	½", ¾", 1", 1¼", 1½" & 2" (Available BSP / NPT)				
End Connection :	Screwed / Flange				
Body Material :	SS ASTM A351 Grade CF8 / CF8M				
Diaphragm :	PTFE + SPL. Viton		PTFE + NBR		
Media Temp :	-10°C to 180°C		-10°C to +90°C		
Circumstance Temp :	-10°C to 70°C				
Media :	Steam, Hot Water, Hot Fluid, Oil				
Main Features :	Internal Parts are in superior corrosion resistance steel, (Equivalent to SS316L) Suitable for Food Industries, Pharmaceuticals, Chemical application & Highly corrosive environment.				
Operating Voltage :	24AC	110AC	230AC	12DC	24DC
Power Consumption :	15W	15W	15W	15W	15W
Coil Features :	High Reliability Unaffected by Voltage Surges. Easy coil changes coil lockable in 4X90 position or freely movable in between as require.				
Coil Housing :	IP65 Epoxy square coil, IP65 Metallic round enclosure, IP67 Flameproof enclosure, IP68 Weatherproof enclosure.				
Optional Feature :	90% Power saver series also available, Water hammering reducer also available to avoid water hammer forces.				
Other Specification Data :	Available on Request.-Manual Override				

Dimension - NC (All dimensions in mm)

All Dimensions are approx.

Model No.	Port Size	Diagram No.	A	B	C	D	E	F
HCP-209I	½"	18.1	67	138	110.5	60	50	63
HCP-309I	¾"	18.1	81	145.2	112.5	71	50	63
HCP-409I	1"	18.1	96	161	120	75	50	63
HCP-509I	1¼"	18.1	108	169.5	123.5	96	50	63
HCP-609I	1½"	18.1	108	169.5	123.5	96	50	63
HCP-809I	2"	18.1	132	196	140.8	114	50	63

In normally open valve dimension B&C will increase up to 8mm.

Section View

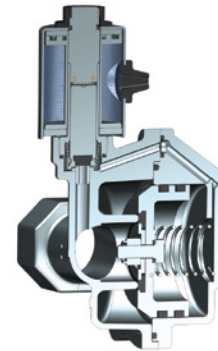

Technical Data

Model No.	Body Material	Pipe (Inch)	Orifice (mm)	Min. Operating Pressure Kg/cm ²	Max. Operating Pressure Kg/cm ²	Seal & Diaphragm Material	Flow Factor Kv m ³ / hr
HCP-2I	CF8 / CF8M	½"	17	1.5	12	SPL. VITON	4
HCP-3I	CF8 / CF8M	¾"	20	1.5	12	SPL. VITON	7
HCP-4I	CF8 / CF8M	1"	25	1.5	12	SPL. VITON	12
HCP-5I	CF8 / CF8M	1¼"	36	1.5	12	SPL. VITON	23
HCP-6I	CF8 / CF8M	1½"	36	1.5	12	SPL. VITON	23
HCP-8I	CF8 / CF8M	2"	47	1.5	12	SPL. VITON	38
HCP-A254I	CF8 / CF8M	½"	17	4	45	PTFE	4
HCP-A354I	CF8 / CF8M	¾"	20	4	45	PTFE	7
HCP-A454I	CF8 / CF8M	1"	25	4	45	PTFE	12
HCP-A554I	CF8 / CF8M	1¼"	36	4	45	PTFE	23
HCP-A654I	CF8 / CF8M	1½"	36	4	45	PTFE	23
HCP-A854I	CF8 / CF8M	2"	47	4	45	PTFE	38

HCP - SERIES PISTON OPERATED SOLENOID VALVE MODEL IDENTIFICATION CHART

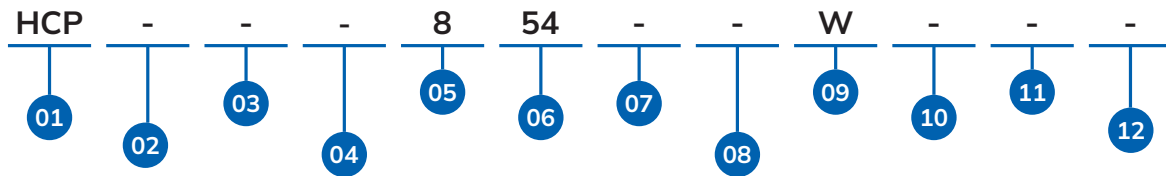

01	SERIES
HCP	

02	PRODUCT TYPE
-	Usd Piston Operated

03	BODY MATERIAL
-	CF8
M	CF8M
C	CF3M
B	Brass Forge
R	Brass Bar

04	SEAL MATERIAL
-	SPL. VITON
A	PTFE
V	VITON

05	PORT SIZE
2	1/2"
3	3/4"
4	1"
5	1-1/4"
6	1-1/2"
8	2"
M	M30 x 1.5

06	PRESSURE RANGE
-	1.5 - 12 Bar
54	4 TO 45 Bar
53	7 TO 22 Bar
61	10 TO 150 Bar

07	PORT CONNECTION
-	BSP
N	NPT
P	BSPT
D	Flange End
A	Flat Face Flange End
C	MM

08	VALVE POSITION
-	NC
Z	NO

09	COIL DIA
I	18mm AC
J	18mm DC
V	18mm FLP AC
W	18mm FLP DC
E	14mm AC
F	14mm DC
G	14mm FLP AC
H	14mm FLP DC
7	14mm Bottom Cable Entry Exp. AC
7D	14mm Bottom Cable Entry Exp. DC
8	18mm Bottom Cable Entry Exp. AC
8D	18mm Bottom Cable Entry Exp. AC

10	FEATURES
-	W/O MOR
M	TURN MOR
P	PUSH MOR

11	CONFIGURATION
-	REGULAR
C1	CONFIG 1
C2	CONFIG 2
C3	CONFIG 3
...	...
C9	CONFIG 9
CA	CONFIG 10
CB	CONFIG 11

12	VERSION
-	VERSION 0
V1	VERSION 1
V2	VERSION 2
V3	VERSION 3
...	...
V9	VERSION 9
VA	VERSION 10
VB	VERSION 11

HCP-854W
2" USD PISTON OPERATED CF8-SPL. VITON-4 TO 45 Bar-BSP-NC-18MM FLP DC

Note : The above chart is for identification purposes only, and it may not be possible to make all combinations for the above chart.

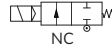
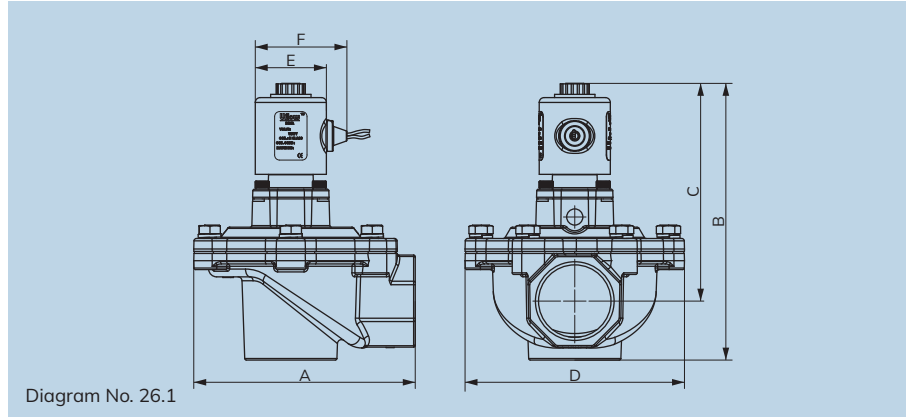

Specifications

Port :	¾", 1", 1½", 2" & 2½" (Available in BSP /NPT)				
End Connection :	Screwed				
Body Material :	Aluminum Die Cast				
Diaphragm:	Nitrile (NBR)				
Media Temp:	-30°C to 90°C				
Circumstance Temp :	-10°C to 70°C				
Media :	Air				
Main Features :	Internal Parts are in superior corrosion resistance steel, (Equivalent to SS316L) Suitable for Air Pollution Control System, Bag Filter Machine				
Operating Voltage :	24AC	110AC	230AC	12DC	24DC
Power Consumption :	9W	9W	9W	10W	11W
Coil Features :	High Reliability Unaffected by Voltage Surges. Easy coil changes coil lockable in 4X90 position or freely movable in between as require.				
Coil Housing :	IP65 Epoxy square coil, IP65 Metallic round enclosure, IP67 Flameproof enclosure, IP68 Weatherproof enclosure.				
Optional Feature :	90% Power saver series also available.				
Other Specification Data :	Available on Request - Brass silencer to reduce extra noise				

NOTE: Use of filter in the inlet port is recommended.

Technical Data

Model No.	Body Material	Pipe (Inch)	Orifice (mm)	Min. Operating Pressure Kg/cm ²	Max. Operating Pressure Kg/cm ²	Seal & Diaphragm Material	Flow Factor Kv m ³ / hr
JAN-3E	Aluminium	¾"	28.50	0.5	8.5	NBR	11
JAN-4E	Aluminium	1"	28.50	0.5	8.5	NBR	16
JAN-6E	Aluminium	1½"	51	0.5	8.5	NBR	40
JAN-8E	Aluminium	2"	52	0.5	8.5	NBR	78
JAN-9E	Aluminium	2½"	65	0.5	8.5	NBR	120
JAN-6ES	Aluminium	1½"	51	0.5	8.5	NBR	40
JAN-8ES	Aluminium	2"	65	0.5	8.5	NBR	78
JAN-9ES	Aluminium	2½"	65	0.5	8.5	NBR	120

Dimension (All dimensions are in mm)

All Dimensions are approx.

Model No.	Port Size	Diagram No.	A	B	C	D	E	F
JAN-3E	¾"	26.1	89	134	110	75	38	49
JAN-4E	1"	26.1	89	134	110	75	38	49
JAN-6E	1½"	26.1	137	171	135	136	38	49
JAN-8E	2"	26.1	171	206	161	169	38	49
JAN-9E	2½"	26.1	171	206	161	169	38	49

Section View

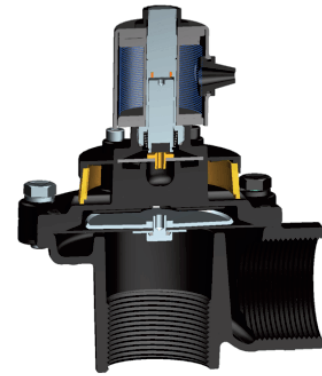

JAN - SERIES PULSE JET ANGLE TYPE DUST COLLECTOR SOLENOID VALVE MODEL CHART

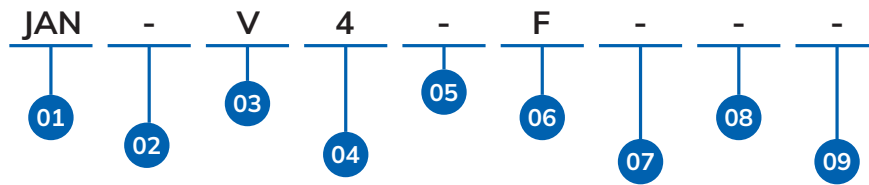

01	SERIES
JAN	

02	PRODUCT TYPE
-	Pulse Jet Angle Type Dust Collector

03	SEAL MATERIAL
-	NITRILE
L	LOW TEMP. NBR
V	VITON

04	PORT SIZE
3	3/4"
4	1"
6	1-1/2"
8	2"
9	2-1/2"

05	PORT CONNECTION
-	BSP
N	NPT

06	COIL DIA
E	14mm AC
F	14mm DC
G	14mm FLP AC
H	14mm FLP DC
5	14mm SS FLP AC
6	14mm SS FLP DC
7	14mm Bottom Cable Entry Exp. AC
7D	18mm Bottom Cable Entry Exp. AC
8	18mm Bottom Cable Entry Exp. AC
8D	18mm Bottom Cable Entry Exp. DC

07	FEATURES
-	REGULAR
S	SILENCER

08	CONFIGURATION
-	REGULAR
C1	CONFIG 1
C2	CONFIG 2
C3	CONFIG 3
⋮	⋮
C9	CONFIG 9
CA	CONFIG 10
CB	CONFIG 11

09	VERSION
-	VERSION 0
V1	VERSION 1
V2	VERSION 2
V3	VERSION 3
⋮	⋮
V9	VERSION 9
VA	VERSION 10
VB	VERSION 11

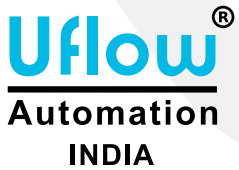

JAN-V4F
 1" PULSE JET ANGLE TYPE DUST COLLECTOR ALUMINIUM-VITON-0.5 TO 8.5 Bar-BSP-14MM DC

Note: The above chart is for identification purposes only, and it may not be possible to make all combinations for the above chart.

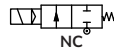

Specifications

Port :	1" - BSP Thread
External Port:	1/8" BSP (F)
End Connection :	Screwed
Body Material :	Aluminium
Diaphragm :	Nitrile (NBR)
Media Temp :	-30°C to 90°C
Circumstance Temp :	-10°C to 70°C
Media :	Air

NOTE: Use of filter in the inlet port is recommended.
Specification may change without prior notice.

Technical Data

Valve Model No.	Body Material	Pipe (Inch)	Orifice (mm)	Min. Operating Pressure Kg/cm ²	Max. Operating Pressure Kg/cm ²	Seal & Diaphragm Material	Flow Factor Kv m ³ / hr
EPS-4	Aluminium	1"	28.5	0.5	8.5	Nitrile (NBR)	16

DIMENSIONS (MM)

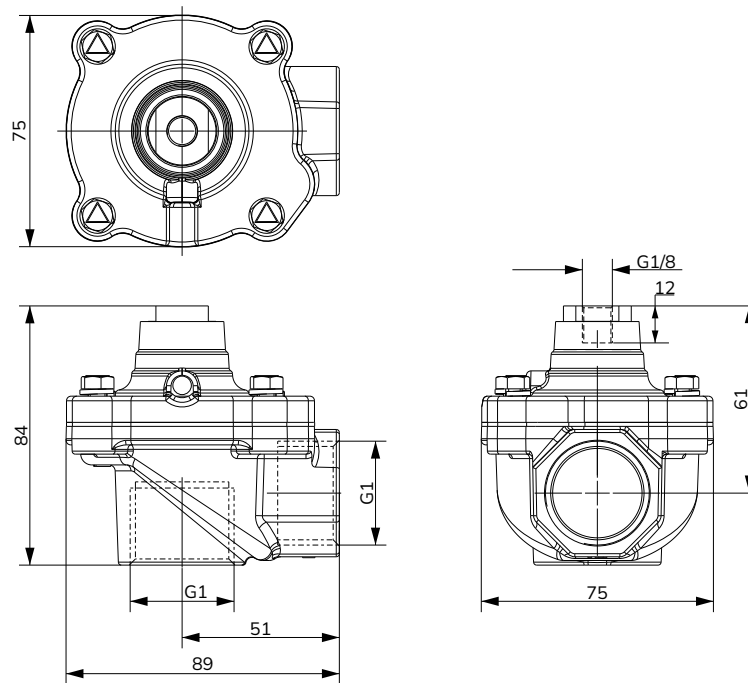

* All dimensions are approx
* Specification may change without prior notice.

EPS - SERIES EXTERNAL PILOT OPERATED PULSE JET ANGLE TYPE DUST COLLECTOR MODEL CHART

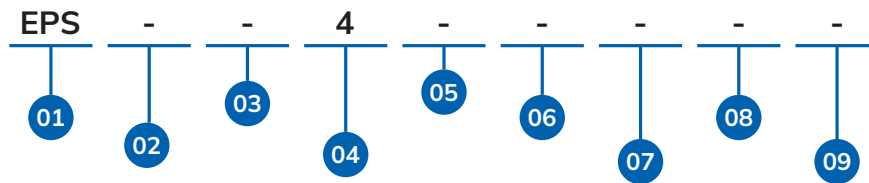

01	SERIES
-	EPS

02	PRODUCT TYPE
-	External Pilot Operated Pulse Jet Angle Type Dust Collector

03	SEAL MATERIAL
-	NITRILE
L	LOW TEMP. NBR
V	VITON

04	PORT SIZE
3	3/4"
4	1"
6	1-1/2"
8	2"
9	2-1/2"

05	PORT CONNECTION
-	BSP
N	NPT

07	FEATURES
-	REGULAR
S	SILENCER

06	EXTERNAL PORT
-	1/8" BSP (F)
N	1/8" NPT (F)
B	1/4" BSP (F)
F	1/4" NPT (F)

08	CONFIGURATION
-	REGULAR
C1	CONFIG 1
C2	CONFIG 2
C3	CONFIG 3
⋮	⋮
C9	CONFIG 9
CA	CONFIG 10
CB	CONFIG 11

09	VERSION
-	VERSION 0
V1	VERSION 1
V2	VERSION 2
V3	VERSION 3
⋮	⋮
V9	VERSION 9
VA	VERSION 10
VB	VERSION 11

EPS-4

1 " BSP EXTERNAL PILOT OPERATED PULSE JET ANGLE TYPE DUST COLLECTOR ALUMINIUM-NITRILE-0.5 TO 8.5 Bar-1/8" BSP

Note: The above chart is for identification purposes only, and it may not be possible to make all combinations for the above chart.

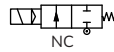
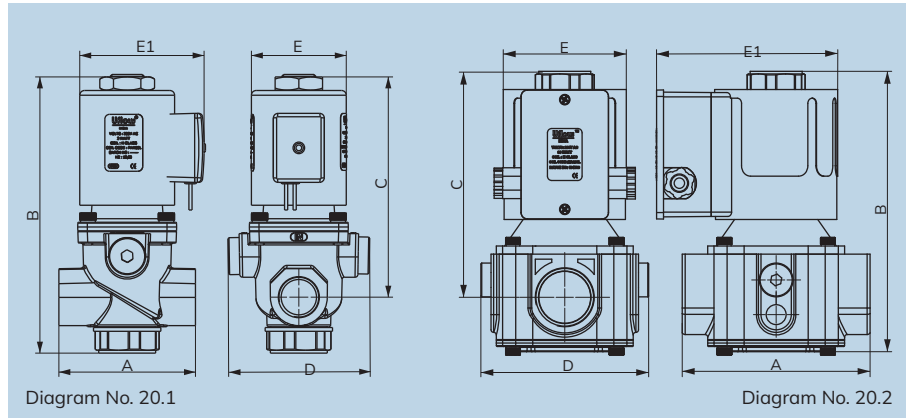

Specifications

Port :	½" & 1" (Available in BSP)	
End Connection :	Screwed	
Body Material :	Aluminum Pressure Die Cast	
Diaphragm :	Nitrile (NBR)	
Media Temp :	-30°C to 90°C	
Circumstance Temp :	-10°C to 70°C	
Media :	Air, Natural Gas, Town Gas	
Main Features :	Flow adjustment, Opening time adjustment, Quick release initial flow adjustment	
Operating Voltage :	110AC	230AC
Power Consumption :	30W	30W
Coil Features :	High Reliability Unaffected by Voltage Surges. Easy coil changes coil lockable in 4X90 position or freely movable in between as require.	
Coil Housing :	IP65 Epoxy square coil & Power Saver Coil	

NOTE: Use of filter in the inlet port is recommended.

- Coils are conforming as per IEC-60335-1 with derivatives (LVD / EMC).
- Gas Solenoid Valve complies as per EN-161 requirement.

Dimension (All dimensions are in mm)

All Dimensions are approx.

Model No.	Port Size	Diagram No.	A	B	C	D	E	E1
UGS-201I	½"	20.1	72	147	117	75	50	66
UGS-400K	1"	20.2	108	164	132	97	71	105

Section View

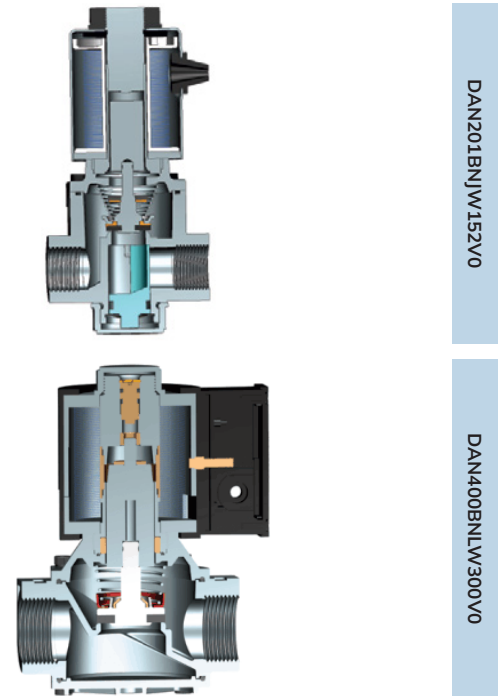

Technical Data

Model No.	Body Material	Pipe (Inch)	Orifice (mm)	Min. Operating Pressure mbar	Max. Operating Pressure mbar	Seal & Diaphragm Material	Flow Factor Kv m³ / hr
UGS-201I	Aluminium	½"	15	0	500	NBR	4
UGS-400K	Aluminium	1"	30	0	350	NBR	13

NOTE: Please refer the direct acting model identification chart.

UGS - SERIES DIRECT ACTING GAS SOLENOID VALVE MODEL CHART

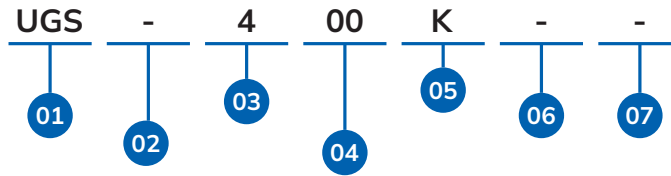

01	SERIES
UGS	

02	PRODUCT TYPE
-	2 WAY

03	PORT SIZE
2	1/2"
4	1"

04	PRESSURE RANGE
00	0 - 350 Mbar
01	0 - 500 Mbar

05	COIL DIA
I	18mm AC
K	30mm AC
7	14mm Bottom Cable Entry Exp. AC
7D	14mm Bottom Cable Entry Exp. DC
8	18mm Bottom Cable Entry Exp.AC
8D	18mm Bottom Cable Entry Exp. DC

06	CONFIGURATION
-	REGULAR
C1	CONFIG 1
C2	CONFIG 2
C3	CONFIG 3
⋮	⋮
C9	CONFIG 9
CA	CONFIG 10
CB	CONFIG 12

07	VERSION
-	VERSION 0
V1	VERSION 1
V2	VERSION 2
V3	VERSION 3
⋮	⋮
V9	VERSION 9
VA	VERSION 10
VB	VERSION 11

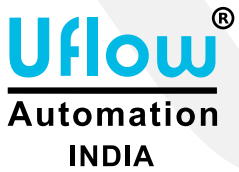

UGS-400K
1" 2 WAY DIRECT ACTING ALUMINIUM-NITRILE-0 TO 350 MBar-BSP-NC-30MM AC

Note: The above chart is for identification purposes only, and it may not be possible to make all combinations for the above chart.

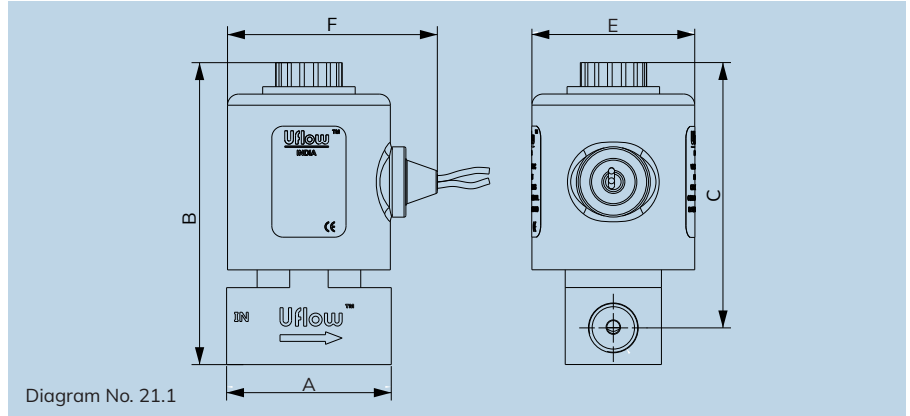
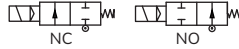

Diagram No. 21.1



Specifications

Port :	1/8", 1/4", 3/8" & 1/2" (Available BSP / NPT)				
End Connection :	Screwed				
Body Material :	SS ASTM A351 Grade CF8 / CF8M, Forged Brass, Aluminium				
Diaphragm:	Nitrile (NBR)	EPDM	Viton (FKM)	Silicone	
Media Temp:	-30°C to 90°C	-10°C to 140°C	-10°C to 180°C	-10°C to 60°C	
Circumstance Temp :	-10°C to 70°C				
Media :	Air, Chemical, Gas, Oil, Steam, Hot Water				
Main Features :	Internal Parts are in superior corrosion resistance steel, (Equivalent to SS316L) Suitable for Food Industries, Pharmaceuticals, Chemical application & Highly corrosive environment.				
Operating Voltage :	24AC	110AC	230AC	12DC	24DC
Power Consumption :	9W	9W	9W	10W	11W
Coil Features :	High Reliability Unaffected by Voltage Surges. Easy coil changes coil lockable in 4X90 position or freely movable in between as require.				
Coil Housing :	IP65 Epoxy square coil, IP65 Metallic round enclosure, IP67 Flameproof enclosure, IP68 Weatherproof enclosure.				
Optional Feature :	90% Power saver series also available & Latching as per Application.				
Other Specification Data :	Available on Request. - Manual Override				

NOTE: Use of filter in the inlet port is recommended.

Dimension - NC (All dimensions in mm)

All Dimensions are approx.

Model No.	Port Size	Diagram No.	A	B	C	E	F
DAS-DA104E030	1/4"	21.1	44.5	81	71	38	49
DAS-DB104E040	1/4"	21.1	43	83	74	38	49
DAS-D104E040	1/4"	21.1	43	83	74	38	49
DAS-DR704E040	3/8"	21.1	48	88	75	38	49
DAS-DR204E040	1/2"	21.1	48	88	75	38	49
DAS-D202I120	1/2"	21.1	55	109	96	50	62
DAS-DA204I050	1/2"	21.1	53	102	88	50	62
DAS-DR004C020	1/8"	21.1	38	58	49	28	33
DAS-D204E040	1/2"	21.1	48	88	75	38	49

In normally open valve dimension B&C will increase up to 8mm.

Section View

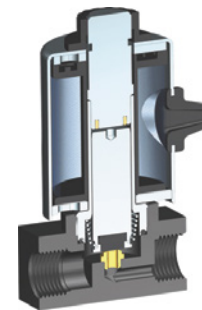

Technical Data

Model No.	Body Material	Port Size	Orifice (mm)		Min. Operating Pressure Kg/cm ²	Max. Operating Pressure Kg/cm ²	Seal & Diaphragm Material	Flow Factor Kv m ³ / hr	
			NC	NO				NC	NO
DAS-DA113F050	Aluminium	1/4"	5	4	0	4	NBR / FKM / EPDM	0.73	0.54
DAS-DA104E030	Aluminium	1/4"	3	2.5	0	10	NBR / FKM / EPDM	0.20	0.16
DAS-DA105E022	Aluminium	1/4"	2.2	1.8	0	16	NBR / FKM / EPDM	0.16	0.10
DAS-DA111E022	Aluminium	1/4"	2.2	1.8	0	25	NBR / FKM / EPDM	0.16	0.10
DAS-DA118E018	Aluminium	1/4"	1.8	1.3	0	40	NBR / FKM / EPDM	0.10	0.05
DAS-DA117E015	Aluminium	1/4"	1.5	1.3	0	60	NBR / FKM / EPDM	0.07	0.05
DAS-DA204I050	Aluminium	1/2"	5	NA	0	10	NBR / FKM / EPDM	0.73	-

Technical Data

Model No.	Body Material	Port Size	Orifice (mm)		Min. Operating Pressure Kg/cm ²	Max. Operating Pressure Kg/cm ²	Seal & Diaphragm Material	Flow Factor Kv m ³ / hr	
			NC	NO				NC	NO
DAS-DA204E040	Aluminium	½"	4	2.5	0	10	NBR / FKM / EPDM	0.54	0.16
DAS-DA205E030	Aluminium	½"	3	2	0	16	NBR / FKM / EPDM	0.20	0.11
DAS-DA204I050	Aluminium	½"	5	4	0	10	NBR / FKM / EPDM	0.73	0.54
DAS-DA217I025	Aluminium	½"	2.5	NA	0	60	NBR / FKM / EPDM	0.16	-
DAS-DR017E018	Brass	⅛"	1.8	NA	0	60	NBR / FKM / EPDM	0.10	-
DAS-DR115E060	Brass	¼"	6	NA	0	1	NBR / FKM / EPDM	0.84	-
DAS-DR113E050	Brass	¼"	5	4	0	4	NBR / FKM / EPDM	0.73	0.54
DAS-DR104E040	Brass	¼"	4	2.5	0	10	NBR / FKM / EPDM	0.54	0.16
DAS-DR105E030	Brass	¼"	3	2.5	0	16	NBR / FKM / EPDM	0.20	0.16
DAS-DR111E025	Brass	¼"	2.5	1.8	0	25	NBR / FKM / EPDM	0.16	0.10
DAS-DR118E020	Brass	¼"	2	1.3	0	40	NBR / FKM / EPDM	0.11	0.05
DAS-DR117E018	Brass	¼"	1.8	1.3	0	60	NBR / FKM / EPDM	0.10	0.05
DAS-DR120E015	Brass	¼"	1.5	0.9	0	100	NBR / FKM / EPDM	0.07	0.03
DAS-DR112E013	Brass	¼"	1.3	NA	0	150	NBR / FKM / EPDM	0.05	--
DAS-DR713E050	Brass	⅜"	5	4	0	4	NBR / FKM / EPDM	0.73	0.54
DAS-DR704E040	Brass	⅜"	4	2.5	0	10	NBR / FKM / EPDM	0.54	0.16
DAS-DR705E030	Brass	⅜"	3	2	0	16	NBR / FKM / EPDM	0.20	0.11
DAS-DR711E025	Brass	⅜"	2.5	1.8	0	25	NBR / FKM / EPDM	0.16	0.10
DAS-DR718E020	Brass	⅜"	2	1.5	0	40	NBR / FKM / EPDM	0.11	0.03
DAS-DR717E018	Brass	⅜"	1.8	1.3	0	60	NBR / FKM / EPDM	0.10	0.05
DAS-DR720E015	Brass	⅜"	1.5	0.9	0	100	NBR / FKM / EPDM	0.07	0.03
DAS-DR712E013	Brass	⅜"	1.3	NA	0	150	NBR / FKM / EPDM	0.05	--
DAS-DR215E060	Brass	½"	6	NA	0	1	NBR / FKM / EPDM	0.84	--
DAS-DR213E050	Brass	½"	5	4	0	4	NBR / FKM / EPDM	0.73	0.54
DAS-DR204E040	Brass	½"	4	2.5	0	10	NBR / FKM / EPDM	0.54	0.16
DAS-DR205E030	Brass	½"	3	2.5	0	16	NBR / FKM / EPDM	0.20	0.16
DAS-DR211E025	Brass	½"	2.5	1.8	0	25	NBR / FKM / EPDM	0.16	0.10
DAS-DR218E020	Brass	½"	2	1.3	0	40	NBR / FKM / EPDM	0.11	0.05
DAS-DR217E018	Brass	½"	1.8	1.3	0	60	NBR / FKM / EPDM	0.10	0.05
DAS-DR220E015	Brass	½"	1.5	0.9	0	100	NBR / FKM / EPDM	0.07	0.03
DAS-DR212E013	Brass	½"	1.3	NA	0	150	NBR / FKM / EPDM	0.05	--
DAS-D017E018	SS304	⅛"	1.8	NA	0	60	NBR / FKM / EPDM	0.16	--
DAS-D115E060	SS304	¼"	6	6	0	1	NBR / FKM / EPDM	0.84	0.84
DAS-D113E050	SS304	¼"	5	4	0	4	NBR / FKM / EPDM	0.73	0.54
DAS-D104E040	SS304	¼"	4	2.5	0	10	NBR / FKM / EPDM	0.54	0.16
DAS-D105E030	SS304	¼"	3	2	0	16	NBR / FKM / EPDM	0.20	0.11
DAS-D111E025	SS304	¼"	2.5	1.8	0	25	NBR / FKM / EPDM	0.16	0.10
DAS-D118E020	SS304	¼"	2	1.3	0	40	NBR / FKM / EPDM	0.11	0.05
DAS-D117E018	SS304	¼"	1.8	1.3	0	60	NBR / FKM / EPDM	0.10	0.05
DAS-D120E015	SS304	¼"	1.5	0.9	0	100	NBR / FKM / EPDM	0.07	0.03
DAS-D112E013	SS304	¼"	1.3	NA	0	150	NBR / FKM / EPDM	0.05	--
DAS-D713E050	SS304	⅜"	5	4	0	4	NBR / FKM / EPDM	0.73	0.54
DAS-D704E040	SS304	⅜"	4	2.5	0	10	NBR / FKM / EPDM	0.54	0.16
DAS-D705E030	SS304	⅜"	3	2	0	16	NBR / FKM / EPDM	0.20	0.11
DAS-D711E025	SS304	⅜"	2.5	1.8	0	25	NBR / FKM / EPDM	0.16	0.10

Technical Data

Model No.	Body Material	Port Size	Orifice (mm)		Min. Operating Pressure Kg/cm ²	Max. Operating Pressure Kg/cm ²	Seal & Diaphragm Material	Flow Factor Kv m ³ / hr	
			NC	NO				NC	NO
DAS-D718E020	SS304	3/8"	2	1.3	0	40	NBR / FKM / EPDM	0.11	0.05
DAS-D717E018	SS304	3/8"	1.8	1.3	0	60	NBR / FKM / EPDM	0.10	0.05
DAS-D720E015	SS304	3/8"	1.5	0.9	0	100	NBR / FKM / EPDM	0.07	0.03
DAS-D712E013	SS304	3/8"	1.3	NA	0	150	NBR / FKM / EPDM	0.05	--
DAS-DS226E170	SS304	1/2"	17	NA	0	0.200	NBR / SI / FKM / EPDM	3.20	--
DAS-D213E050	SS304	1/2"	5	4	0	4	NBR / FKM / EPDM	0.73	0.54
DAS-D204E040	SS304	1/2"	4	2.5	0	10	NBR / FKM / EPDM	0.54	0.16
DAS-D205E030	SS304	1/2"	3	2.5	0	16	NBR / FKM / EPDM	0.20	0.16
DAS-D211E025	SS304	1/2"	2.5	1.8	0	25	NBR / FKM / EPDM	0.16	0.10
DAS-D218E020	SS304	1/2"	2	1.3	0	40	NBR / FKM / EPDM	0.11	0.05
DAS-D217E018	SS304	1/2"	1.8	1.3	0	60	NBR / FKM / EPDM	0.10	0.05
DAS-D220E015	SS304	1/2"	1.5	0.9	0	100	NBR / FKM / EPDM	0.07	0.03
DAS-D212E013	SS304	1/2"	1.3	NA	0	150	NBR / FKM / EPDM	0.05	--
DAS-DS202I120	SS304	1/2"	12	NA	0	2	NBR / SI / FKM / EPDM	2.10	--
DAS-D202I120	SS304	1/2"	12	NA	0	2	NBR / FKM / EPDM	2.10	--
DAS-D201I120	SS304	1/2"	12	12	0	0.500	NBR / FKM / EPDM	2.10	2.10
DAS-DA004C020	Aluminum	1/8"	2	NA	0	10	NBR / FKM / EPDM	0.11	--
DAS-DA102C025	Aluminum	1/4"	2.5	NA	0	2	NBR / FKM / EPDM	0.16	--
DAS-DA104C020	Aluminum	1/4"	2	NA	0	10	NBR / FKM / EPDM	0.11	--
DAS-DR014C030	Brass	1/8"	3	NA	0	3	NBR / FKM / EPDM	0.20	--
DAS-DR004C020	Brass	1/8"	2	NA	0	10	NBR / FKM / EPDM	0.11	--
DAS-DR104C020	Brass	1/4"	2	NA	0	10	NBR / FKM / EPDM	0.11	--
DAS-D102C020	SS304	1/4"	2	NA	0	2	NBR / FKM / EPDM	0.11	--
DAS-D103C025	SS304	1/4"	2.5	NA	0	7	NBR / FKM / EPDM	0.16	--
DAS-D104C020	SS304	1/4"	2	NA	0	10	NBR / FKM / EPDM	0.11	--

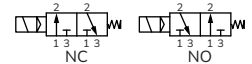
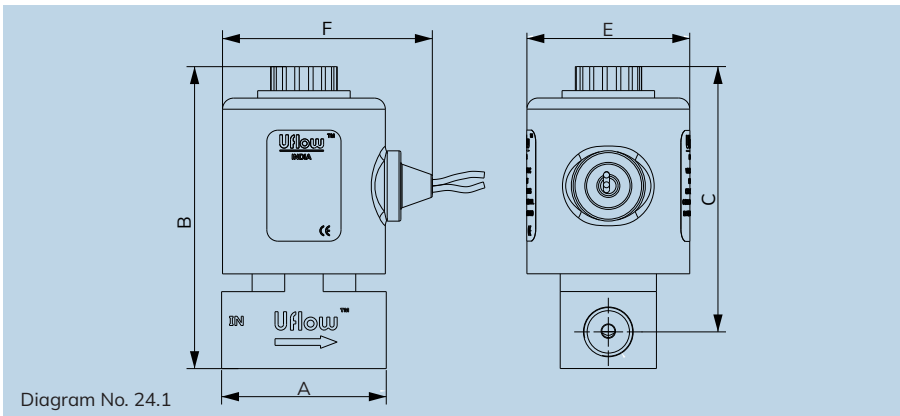

Specifications

Port :	1/8", 1/4", 3/8" & 1/2" (Available BSP / NPT)				
End Connection :	Screwed				
Body Material :	SS ASTM A351 Grade CF8 / CF8M, Forged Brass, Aluminium				
Diaphragm:	Nitrile (NBR)	EPDM	Viton (FKM)		
Media Temp:	-30°C to 90°C	-10°C to 140°C	-10°C to 180°C		
Circumstance Temp :	-10°C to 70°C				
Media :	Air, Water, Chemical, Gas, Oil, Diesel, Kerosene, LPG.				
Main Features :	Internal Parts are in superior corrosion resistance steel, (Equivalent to SS316L) Suitable for Food Industries, Pharmaceuticals, Chemical application & Highly corrosive environment.				
Operating Voltage :	24AC	110AC	230AC	12DC	24DC
Power Consumption :	9W	9W	9W	10W	11W
Coil Features :	High Reliability Unaffected by Voltage Surges. Easy coil changes coil lockable in 4X90 position or freely movable in between as require.				
Coil Housing :	IP65 Epoxy square coil, IP65 Metallic round enclosure, IP67 Flameproof enclosure, IP68 Weatherproof enclosure.				
Optional Feature :	90% Power saver series also available.				
Other Specification Data :	Available on Request. - Manual Override				

NOTE: Use of filter in the inlet port is recommended.

Dimension - NC (All dimensions are in mm)

All Dimensions are approx.

Model No.	Port Size	Diagram No.	A	B	C	E	F
DAS-TA104E015	1/4"	24.1	45	93	83	38	49
DAS-TR104E015	1/4"	24.1	43	95	86	38	49
DAS-T104E015	1/4"	24.1	43	95	85	38	49
DAS-TR704E015	3/8"	24.1	48	100	86	38	49
DAS-TR204E015	1/2"	24.1	48	100	87	38	49
DAS-T204E015	1/2"	24.1	48	100	86	38	49
DAS-TR004C012	1/8"	24.1	38	58	49	28	33
DAS-TR104C012	1/4"	24.1	38	58	49	28	33

In normally open valve dimension B&C will increase up to 8mm.

Section View



Technical Data

Model No.	Body Material	Port Size	Orifice (mm)		Min. Operating Pressure Kg/cm ²	Max. Operating Pressure Kg/cm ²	Seal & Diaphragm Material	Flow Factor Kv m ³ / hr	
			NC	NO				NC	NO
DAS-TA119E025	Aluminium	1/4"	2.5	-	0	5	NBR / FKM / EPDM	0.16	--
DAS-TA104E015	Aluminium	1/4"	1.5	1.5	0	10	NBR / FKM / EPDM	0.07	0.07
DAS-TA105E009	Aluminium	1/4"	0.9	0.9	0	16	NBR / FKM / EPDM	0.03	0.03
DAS-TA111E009	Aluminium	1/4"	0.9	0.9	0	25	NBR / FKM / EPDM	0.03	0.03
DAS-TA118E009	Aluminium	1/4"	0.9	0.9	0	40	NBR / FKM / EPDM	0.03	0.03
DAS-TA104R1E015	Aluminium	In : 1/4", Out : Namur	1.5	-	0	10	NBR / FKM / EPDM	0.07	--
DAS-TA704E015	Aluminium	3/8"	1.5	1.5	0	10	NBR / FKM / EPDM	0.07	0.07
DAS-TA204E015	Aluminium	1/2"	1.5	1.5	0	10	NBR / FKM / EPDM	0.07	0.07

Technical Data

Model No.	Body Material	Port Size	Orifice (mm)		Min. Operating Pressure Kg/cm ²	Max. Operating Pressure Kg/cm ²	Seal & Diaphragm Material	Flow Factor Kv m ³ / hr	
			NC	NO				NC	NO
DAS-TA205E009	Aluminium	½"	0.9	0.9	0	16	NBR / FKM / EPDM	0.03	0.03
DAS-TR004E015	Brass	⅙"	1.5	NA	0	10	NBR / FKM / EPDM	0.07	--
DAS-TR119E025	Brass	¼"	2.5	NA	0	5	NBR / FKM / EPDM	0.16	--
DAS-TR104E020	Brass	¼"	2	1.5	0	10	NBR / FKM / EPDM	0.11	0.07
DAS-TR105E009	Brass	¼"	0.9	0.9	0	16	NBR / FKM / EPDM	0.03	0.03
DAS-TR111E009	Brass	¼"	0.9	0.9	0	25	NBR / FKM / EPDM	0.03	0.03
DAS-TR118E009	Brass	¼"	0.9	0.9	0	40	NBR / FKM / EPDM	0.03	0.03
DAS-TR719E025	Brass	⅜"	2.5	NA	0	5	NBR / FKM / EPDM	0.16	--
DAS-TR704E015	Brass	⅜"	1.5	1.5	0	10	NBR / FKM / EPDM	0.07	0.07
DAS-TR705E009	Brass	⅜"	0.9	0.9	0	16	NBR / FKM / EPDM	0.03	0.03
DAS-TR711E009	Brass	⅜"	0.9	0.9	0	25	NBR / FKM / EPDM	0.03	0.03
DAS-TR219E025	Brass	½"	2.5	NA	0	5	NBR / FKM / EPDM	0.16	--
DAS-TR204E015	Brass	½"	1.5	1.5	0	10	NBR / FKM / EPDM	0.07	0.07
DAS-TR205E009	Brass	½"	0.9	0.9	0	16	NBR / FKM / EPDM	0.03	0.03
DAS-TR211E009	Brass	½"	0.9	0.9	0	25	NBR / FKM / EPDM	0.03	0.03
DAS-TR218E009	Brass	½"	0.9	0.9	0	40	NBR / FKM / EPDM	0.03	0.03
DAS-T119E025	SS304	¼"	2.5	NA	0	5	NBR / FKM / EPDM	0.16	--
DAS-T104E015	SS304	¼"	1.5	1.5	0	10	NBR / FKM / EPDM	0.07	0.07
DAS-T105E009	SS304	¼"	0.9	0.9	0	16	NBR / FKM / EPDM	0.03	0.03
DAS-T118E009	SS304	¼"	0.9	0.9	0	40	NBR / FKM / EPDM	0.03	0.03
DAS-T111E009	SS304	¼"	0.9	0.9	0	25	NBR / FKM / EPDM	0.03	0.03
DAS-T719E025	SS304	⅜"	2.5	NA	0	5	NBR / FKM / EPDM	0.16	--
DAS-T704E015	SS304	⅜"	1.5	1.5	0	10	NBR / FKM / EPDM	0.07	0.07
DAS-T705E009	SS304	⅜"	0.9	0.9	0	16	NBR / FKM / EPDM	0.03	0.03
DAS-T711E009	SS304	⅜"	0.9	0.9	0	25	NBR / FKM / EPDM	0.03	0.03
DAS-T219E025	SS304	½"	2.5	NA	0	5	NBR / FKM / EPDM	0.16	--
DAS-T204E015	SS304	½"	1.5	1.5	0	10	NBR / FKM / EPDM	0.07	0.07
DAS-T205E009	SS304	½"	0.9	0.9	0	16	NBR / FKM / EPDM	0.03	0.03
DAS-T211E009	SS304	½"	0.9	0.9	0	25	NBR / FKM / EPDM	0.03	0.03
DAS-TA104C012	Aluminium	¼"	1.2	NA	0	10	NBR / FKM / EPDM	0.04	--
DAS-TR014C025	Brass	⅙"	2.5	NA	0	3	NBR / FKM / EPDM	0.16	--
DAS-TR004C012	Brass	⅙"	1.2	NA	0	10	NBR / FKM / EPDM	0.04	--
DAS-TR104C012	Brass	¼"	1.2	NA	0	10	NBR / FKM / EPDM	0.04	--
DAS-TR103C012	Brass	¼"	1.2	NA	0	7	NBR / FKM / EPDM	0.04	--
DAS-TR114C025	Brass	¼"	2.5	NA	0	3	NBR / FKM / EPDM	0.16	--
DAS-T103C016	SS304	¼"	1.6	NA	0	7	NBR / FKM / EPDM	0.07	--
DAS-T718E009	SS304	⅜"	0.9	NA	0	40	NBR / FKM / EPDM	0.03	--

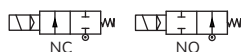
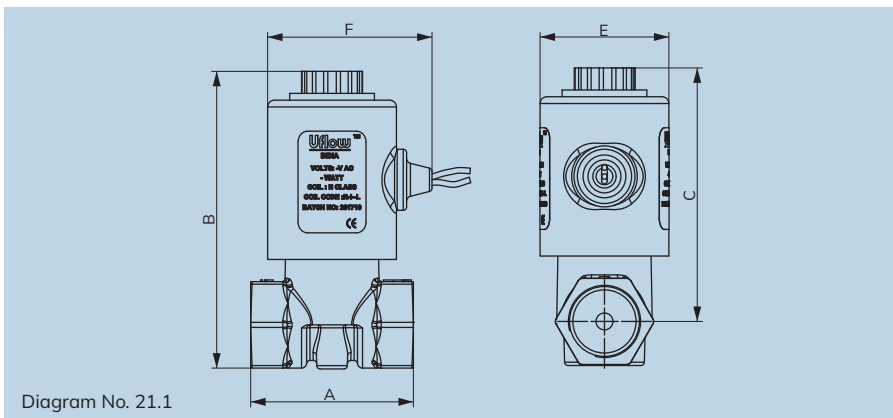
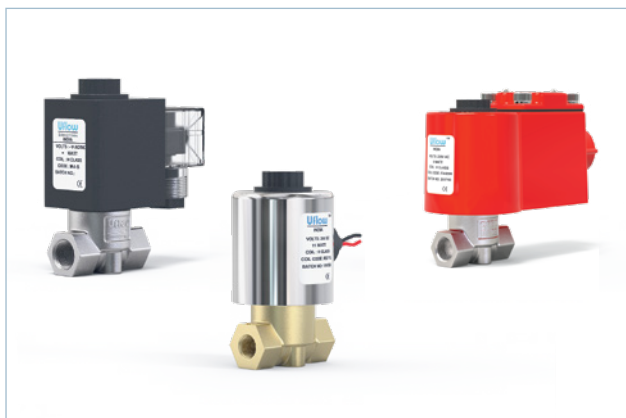

Specifications

Port :	1/8", 1/4", 3/8" & 1/2" (Available BSP / NPT)				
End Connection :	Screwed				
Body Material :	SS ASTM A351 Grade CF8 / CF8M, Forged Brass, Aluminium				
Diaphragm:	Nitrile (NBR)	EPDM	Viton (FKM)	Silicone	
Media Temp:	-30°C to 90°C	-10°C to 140°C	-10°C to 180°C	-10°C to 60°C	
Circumstance Temp :	-10°C to 70°C				
Media :	Air, Chemical, Gas, Oil, Steam, Hot Water				
Main Features :	Internal Parts are in superior corrosion resistance steel, (Equivalent to SS316L) Suitable for Food Industries, Pharmaceuticals, Chemical application & Highly corrosive environment.				
Operating Voltage :	24AC	110AC	230AC	12DC	24DC
Power Consumption :	9W	9W	9W	10W	11W
Coil Features :	High Reliability Unaffected by Voltage Surges. Easy coil changes coil lockable in 4X90 position or freely movable in between as require.				
Coil Housing :	IP65 Epoxy square coil, IP65 Metallic round enclosure, IP67 Flameproof enclosure, IP68 Weatherproof enclosure.				
Optional Feature :	90% Power saver series also available & Latching as per Application.				
Other Specification Data :	Available on Request. - Manual Override				

NOTE: Use of filter in the inlet port is recommended.

Dimension - NC (All dimensions in mm)

All Dimensions are approx.

Model No.	Port Size	Diagram No.	A	B	C	E	F
DAC-DB104E040	1/4"	21.1	43	83	74	38	49
DAC-D104E040	1/4"	21.1	43	83	74	38	49
DAC-DB704E040	3/8"	21.1	48	88	75	38	49
DAC-DB204E040	1/2"	21.1	48	88	75	38	49
DAC-D2021120	1/2"	21.1	55	109	96	50	62
DAC-DB004C020	1/8"	21.1	38	58	49	28	33
DAC-D204E040	1/2"	21.1	48	88	75	38	49

In normally open valve dimension B&C will increase up to 8mm.

Section View



Technical Data

Model No.	Body Material	Port Size	Orifice (mm)		Min. Operating Pressure Kg/cm ²	Max. Operating Pressure Kg/cm ²	Seal & Diaphragm Material	Flow Factor Kv m ³ / hr	
			NC	NO				NC	NO
DAC-DB017E018	Brass	1/8"	1.8	NA	0	60	NBR / FKM / EPDM	0.10	-
DAC-DB115E060	Brass	1/4"	6	NA	0	1	NBR / FKM / EPDM	0.84	-
DAC-DB113E050	Brass	1/4"	5	4	0	4	NBR / FKM / EPDM	0.73	0.54
DAC-DB104E040	Brass	1/4"	4	2.5	0	10	NBR / FKM / EPDM	0.54	0.16
DAC-DB105E030	Brass	1/4"	3	2.5	0	16	NBR / FKM / EPDM	0.20	0.16
DAC-DB111E025	Brass	1/4"	2.5	1.8	0	25	NBR / FKM / EPDM	0.16	0.10
DAC-DB118E020	Brass	1/4"	2	1.3	0	40	NBR / FKM / EPDM	0.11	0.05

Technical Data

Model No.	Body Material	Port Size	Orifice (mm)		Min. Operating Pressure Kg/cm ²	Max. Operating Pressure Kg/cm ²	Seal & Diaphragm Material	Flow Factor Kv m ³ / hr	
			NC	NO				NC	NO
DAC-DB117E018	Brass	¼"	1.8	1.3	0	60	NBR / FKM / EPDM	0.10	0.05
DAC-DB120E015	Brass	¼"	1.5	0.9	0	100	NBR / FKM / EPDM	0.07	0.03
DAC-DB112E013	Brass	¼"	1.3	NA	0	150	NBR / FKM / EPDM	0.05	--
DAC-DB713E050	Brass	⅜"	5	4	0	4	NBR / FKM / EPDM	0.73	0.54
DAC-DB704E040	Brass	⅜"	4	2.5	0	10	NBR / FKM / EPDM	0.54	0.16
DAC-DB705E030	Brass	⅜"	3	2	0	16	NBR / FKM / EPDM	0.20	0.11
DAC-DB711E025	Brass	⅜"	2.5	1.8	0	25	NBR / FKM / EPDM	0.16	0.10
DAC-DB718E020	Brass	⅜"	2	1.5	0	40	NBR / FKM / EPDM	0.11	0.03
DAC-DB717E018	Brass	⅜"	1.8	1.3	0	60	NBR / FKM / EPDM	0.10	0.05
DAC-DB720E015	Brass	⅜"	1.5	0.9	0	100	NBR / FKM / EPDM	0.07	0.03
DAC-DB712E013	Brass	⅜"	1.3	NA	0	150	NBR / FKM / EPDM	0.05	--
DAC-DB215E060	Brass	½"	6	NA	0	1	NBR / FKM / EPDM	0.84	--
DAC-DB213E050	Brass	½"	5	4	0	4	NBR / FKM / EPDM	0.73	0.54
DAC-DB204E040	Brass	½"	4	2.5	0	10	NBR / FKM / EPDM	0.54	0.16
DAC-DB205E030	Brass	½"	3	2.5	0	16	NBR / FKM / EPDM	0.20	0.16
DAC-DB211E025	Brass	½"	2.5	1.8	0	25	NBR / FKM / EPDM	0.16	0.10
DAC-DB218E020	Brass	½"	2	1.3	0	40	NBR / FKM / EPDM	0.11	0.05
DAC-DB217E018	Brass	½"	1.8	1.3	0	60	NBR / FKM / EPDM	0.10	0.05
DAC-DB220E015	Brass	½"	1.5	0.9	0	100	NBR / FKM / EPDM	0.07	0.03
DAC-DB212E013	Brass	½"	1.3	NA	0	150	NBR / FKM / EPDM	0.05	--
DAC-D017E018	SS304	⅜"	1.8	NA	0	60	NBR / FKM / EPDM	0.16	--
DAC-D115E060	SS304	¼"	6	6	0	1	NBR / FKM / EPDM	0.84	0.84
DAC-D113E050	SS304	¼"	5	4	0	4	NBR / FKM / EPDM	0.73	0.54
DAC-D104E040	SS304	¼"	4	2.5	0	10	NBR / FKM / EPDM	0.54	0.16
DAC-D105E030	SS304	¼"	3	2	0	16	NBR / FKM / EPDM	0.20	0.11
DAC-D111E025	SS304	¼"	2.5	1.8	0	25	NBR / FKM / EPDM	0.16	0.10
DAC-D118E020	SS304	¼"	2	1.3	0	40	NBR / FKM / EPDM	0.11	0.05
DAC-D117E018	SS304	¼"	1.8	1.3	0	60	NBR / FKM / EPDM	0.10	0.05
DAC-D120E015	SS304	¼"	1.5	0.9	0	100	NBR / FKM / EPDM	0.07	0.03
DAC-D112E013	SS304	¼"	1.3	NA	0	150	NBR / FKM / EPDM	0.05	--
DAC-D713E050	SS304	⅜"	5	4	0	4	NBR / FKM / EPDM	0.73	0.54
DAC-D704E040	SS304	⅜"	4	2.5	0	10	NBR / FKM / EPDM	0.54	0.16
DAC-D705E030	SS304	⅜"	3	2	0	16	NBR / FKM / EPDM	0.20	0.11
DAC-D711E025	SS304	⅜"	2.5	1.8	0	25	NBR / FKM / EPDM	0.16	0.10
DAC-D718E020	SS304	⅜"	2	1.3	0	40	NBR / FKM / EPDM	0.11	0.05
DAC-D717E018	SS304	⅜"	1.8	1.3	0	60	NBR / FKM / EPDM	0.10	0.05
DAC-D720E015	SS304	⅜"	1.5	0.9	0	100	NBR / FKM / EPDM	0.07	0.03
DAC-D712E013	SS304	⅜"	1.3	NA	0	150	NBR / FKM / EPDM	0.05	--
DAC-DS226E170	SS304	½"	17	NA	0	0.200	NBR / SI / FKM / EPDM	3.20	--
DAC-D213E050	SS304	½"	5	4	0	4	NBR / FKM / EPDM	0.73	0.54
DAC-D204E040	SS304	½"	4	2.5	0	10	NBR / FKM / EPDM	0.54	0.16
DAC-D205E030	SS304	½"	3	2.5	0	16	NBR / FKM / EPDM	0.20	0.16
DAC-D211E025	SS304	½"	2.5	1.8	0	25	NBR / FKM / EPDM	0.16	0.10
DAC-D218E020	SS304	½"	2	1.3	0	40	NBR / FKM / EPDM	0.11	0.05
DAC-D217E018	SS304	½"	1.8	1.3	0	60	NBR / FKM / EPDM	0.10	0.05

Technical Data

Model No.	Body Material	Port Size	Orifice (mm)		Min. Operating Pressure Kg/cm ²	Max. Operating Pressure Kg/cm ²	Seal & Diaphragm Material	Flow Factor Kv m ³ / hr	
			NC	NO				NC	NO
DAC-D220E015	SS304	½"	1.5	0.9	0	100	NBR / FKM / EPDM	0.07	0.03
DAC-D212E013	SS304	½"	1.3	NA	0	150	NBR / FKM / EPDM	0.05	--
DAC-DS202I120	SS304	½"	12	NA	0	2	NBR / SI / FKM / EPDM	2.10	--
DAC-D202I120	SS304	½"	12	NA	0	2	NBR / FKM / EPDM	2.10	--
DAC-D201I120	SS304	½"	12	12	0	0.500	NBR / FKM / EPDM	2.10	2.10
DAC-DB014C030	Brass	⅛"	3	NA	0	3	NBR / FKM / EPDM	0.20	--
DAC-DB004C020	Brass	⅛"	2	NA	0	10	NBR / FKM / EPDM	0.11	--
DAC-DB104C020	Brass	¼"	2	NA	0	10	NBR / FKM / EPDM	0.11	--
DAC-D102C020	SS304	¼"	2	NA	0	2	NBR / FKM / EPDM	0.11	--
DAC-D103C025	SS304	¼"	2.5	NA	0	7	NBR / FKM / EPDM	0.16	--
DAC-D104C020	SS304	¼"	2	NA	0	10	NBR / FKM / EPDM	0.11	--

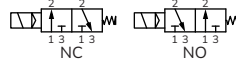
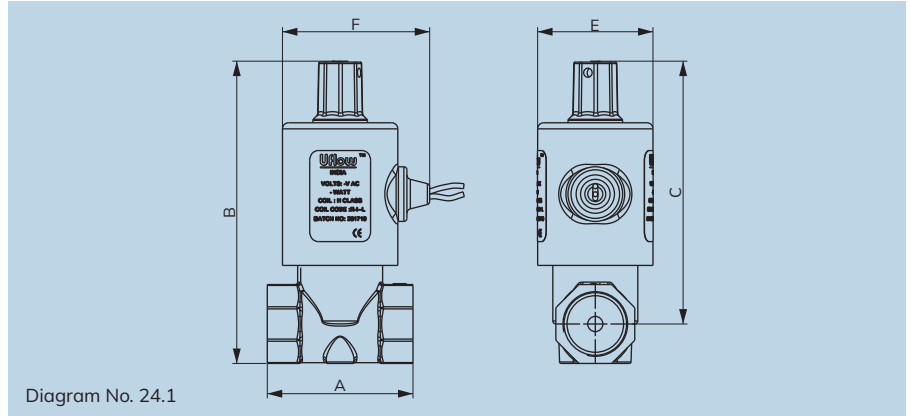

Specifications

Port :	1/8", 1/4", 3/8" & 1/2" (Available BSP / NPT)				
End Connection :	Screwed				
Body Material :	SS ASTM A351 Grade CF8 / CF8M, Forged Brass, Aluminium				
Diaphragm:	Nitrile (NBR)	EPDM	Viton (FKM)		
Media Temp:	-30°C to 90°C	-10°C to 140°C	-10°C to 180°C		
Circumstance Temp :	-10°C to 70°C				
Media :	Air, Water, Chemical, Gas, Oil, Diesel, Kerosene, LPG.				
Main Features :	Internal Parts are in superior corrosion resistance steel, (Equivalent to SS316L) Suitable for Food Industries, Pharmaceuticals, Chemical application & Highly corrosive environment.				
Operating Voltage :	24AC	110AC	230AC	12DC	24DC
Power Consumption :	9W	9W	9W	10W	11W
Coil Features :	High Reliability Unaffected by Voltage Surges. Easy coil changes coil lockable in 4X90 position or freely movable in between as require.				
Coil Housing :	IP65 Epoxy square coil, IP65 Metallic round enclosure, IP67 Flameproof enclosure, IP68 Weatherproof enclosure.				
Optional Feature :	90% Power saver series also available.				
Other Specification Data :	Available on Request. - Manual Override				

NOTE: Use of filter in the inlet port is recommended.

Dimension - NC (All dimensions are in mm)

All Dimensions are approx.

Model No.	Port Size	Diagram No.	A	B	C	E	F
DAC-TB104E015	1/4"	24.1	43	95	86	38	49
DAC-T104E015	1/4"	24.1	43	95	85	38	49
DAC-TB704E015	3/8"	24.1	48	100	86	38	49
DAC-TB204E015	1/2"	24.1	48	100	87	38	49
DAC-T204E015	1/2"	24.1	48	100	86	38	49
DAC-TB004C012	1/8"	24.1	38	58	49	28	33
DAC-TB104C012	1/4"	24.1	38	58	49	28	33

In normally open valve dimension B&C will increase up to 8mm.

Section View

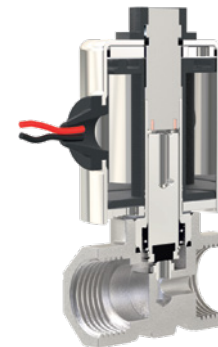

Technical Data

Model No.	Body Material	Port Size	Orifice (mm)		Min. Operating Pressure Kg/cm ²	Max. Operating Pressure Kg/cm ²	Seal & Diaphragm Material	Flow Factor Kv m ³ / hr	
			NC	NO				NC	NO
DAC-TB004E015	Brass	1/8"	1.5	NA	0	10	NBR / FKM / EPDM	0.07	--
DAC-TB119E025	Brass	1/4"	2.5	NA	0	5	NBR / FKM / EPDM	0.16	--
DAC-TB104E020	Brass	1/4"	2	1.5	0	10	NBR / FKM / EPDM	0.11	0.07
DAC-TB105E009	Brass	1/4"	0.9	0.9	0	16	NBR / FKM / EPDM	0.03	0.03
DAC-TB111E009	Brass	1/4"	0.9	0.9	0	25	NBR / FKM / EPDM	0.03	0.03
DAC-TB118E009	Brass	1/4"	0.9	0.9	0	40	NBR / FKM / EPDM	0.03	0.03
DAC-TB719E025	Brass	3/8"	2.5	NA	0	5	NBR / FKM / EPDM	0.16	--
DAC-TB704E015	Brass	3/8"	1.5	1.5	0	10	NBR / FKM / EPDM	0.07	0.07
DAC-TB705E009	Brass	3/8"	0.9	0.9	0	16	NBR / FKM / EPDM	0.03	0.03

Technical Data

Model No.	Body Material	Port Size	Orifice (mm)		Min. Operating Pressure Kg/cm ²	Max. Operating Pressure Kg/cm ²	Seal & Diaphragm Material	Flow Factor Kv m ³ / hr	
			NC	NO				NC	NO
DAC-TB711E009	Brass	3/8"	0.9	0.9	0	25	NBR / FKM / EPDM	0.03	0.03
DAC-TB219E025	Brass	1/2"	2.5	NA	0	5	NBR / FKM / EPDM	0.16	--
DAC-TB204E015	Brass	1/2"	1.5	1.5	0	10	NBR / FKM / EPDM	0.07	0.07
DAC-TB205E009	Brass	1/2"	0.9	0.9	0	16	NBR / FKM / EPDM	0.03	0.03
DAC-TB211E009	Brass	1/2"	0.9	0.9	0	25	NBR / FKM / EPDM	0.03	0.03
DAC-TB218E009	Brass	1/2"	0.9	0.9	0	40	NBR / FKM / EPDM	0.03	0.03
DAC-T119E025	SS304	1/4"	2.5	NA	0	5	NBR / FKM / EPDM	0.16	--
DAC-T104E015	SS304	1/4"	1.5	1.5	0	10	NBR / FKM / EPDM	0.07	0.07
DAC-T105E009	SS304	1/4"	0.9	0.9	0	16	NBR / FKM / EPDM	0.03	0.03
DAC-T118E009	SS304	1/4"	0.9	0.9	0	40	NBR / FKM / EPDM	0.03	0.03
DAC-T111E009	SS304	1/4"	0.9	0.9	0	25	NBR / FKM / EPDM	0.03	0.03
DAC-T719E025	SS304	3/8"	2.5	NA	0	5	NBR / FKM / EPDM	0.16	--
DAC-T704E015	SS304	3/8"	1.5	1.5	0	10	NBR / FKM / EPDM	0.07	0.07
DAC-T705E009	SS304	3/8"	0.9	0.9	0	16	NBR / FKM / EPDM	0.03	0.03
DAC-T711E009	SS304	3/8"	0.9	0.9	0	25	NBR / FKM / EPDM	0.03	0.03
DAC-T219E025	SS304	1/2"	2.5	NA	0	5	NBR / FKM / EPDM	0.16	--
DAC-T204E015	SS304	1/2"	1.5	1.5	0	10	NBR / FKM / EPDM	0.07	0.07
DAC-T205E009	SS304	1/2"	0.9	0.9	0	16	NBR / FKM / EPDM	0.03	0.03
DAC-T211E009	SS304	1/2"	0.9	0.9	0	25	NBR / FKM / EPDM	0.03	0.03
DAC-TB014C025	Brass	1/8"	2.5	NA	0	3	NBR / FKM / EPDM	0.16	--
DAC-TB004C012	Brass	1/8"	1.2	NA	0	10	NBR / FKM / EPDM	0.04	--
DAC-TB104C012	Brass	1/4"	1.2	NA	0	10	NBR / FKM / EPDM	0.04	--
DAC-TB103C012	Brass	1/4"	1.2	NA	0	7	NBR / FKM / EPDM	0.04	--
DAC-TB114C025	Brass	1/4"	2.5	NA	0	3	NBR / FKM / EPDM	0.16	--
DAC-T103C016	SS304	1/4"	1.6	NA	0	7	NBR / FKM / EPDM	0.07	--
DAC-T718E009	SS304	3/8"	0.9	NA	0	40	NBR / FKM / EPDM	0.03	--

DAS - SERIES DIRECT ACTING SQUARE TYPE SOLENOID VALVE MODEL CHART

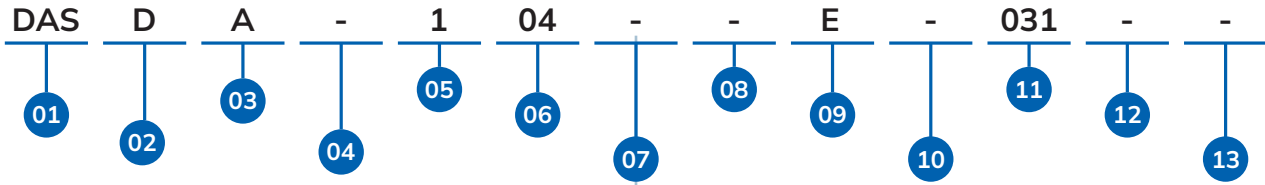

01	SERIES
DAS	

02	PRODUCT TYPE
D	2 Way
T	3 Way

03	BODY MATERIAL
-	SS304
6	SS316
R	Brass Bar
L	SS316L
A	Aluminium

04	SEAL MATERIAL
-	Nitrile
E	EPDM
V	Viton
S	Silicone
F	SPL Viton
U	Fluoro Silicone
J	Viton GLT
P	PTFE
T	Low Temp NBR
D	HNBR
K	PEEK
N	Buna N

05	PORT SIZE
-	1/8"
1	1/4"
2	1/2"
3	3/4"
5	7/8"
7	3/8"
8	M14
H	M5
O	Manifold Mount

06	PRESSURE RANGE	
00	0 to 350 Mbar	21 0 to 20 Bar
01	0 to 500 Mbar	26 0 to 200 MBar
02	0 to 2 Bar	30 0 to 1.5 Bar
03	0 to 7 Bar	31 0 to 6 Bar
04	0 to 10 Bar	32 0 to 8 Bar
05	0 to 16 Bar	34 0 to 10 PSI
07	0.5 to 8.5 Bar	38 0 to 12 Bar
11	0 to 25 Bar	39 0 to 150 Mbar
12	0 to 150 Bar	42 0 to 13 Bar
13	0 to 4 Bar	43 0 to 15 Bar
14	0 to 3 Bar	44 0 to 18 Bar
15	0 to 1 Bar	46 0 to 21 Bar
17	0 to 60 Bar	47 0 to 35 Bra
18	0 to 40 Bar	48 20 to 110 Bar
19	0 to 5 Bar	52 -1 to 1 Bar
20	0 to 100 Bar	

07	PORT CONNECTION
-	BSP
N	NPT
P	BSPT
R1	Namur Bsp
T1	Namur Npt
2	Manifold
4	UNF
9	MM
5	Barb

08	VALVE POSITION
-	NC
Z	NO
Y	Universal
D1	Diverting
X	Mixing
R	BI directional NC
S	BI directional NO

09	COIL DIA
A	8mm AC
B	8mm DC
C	10mm AC
D	10mm DC
E	14mm AC
F	14mm DC
G	14mm FLP AC
H	14mm FLP DC
I	18mm AC
J	18mm DC
K	30mm AC
L	30mm DC
M	28mm
O	5.5mm DC
Q	5mm DC
T	12mm AC
U	12mm DC
V	18mm FLP AC
W	18mm FLP DC
5	14mm SS FLP AC
6	14mm SS FLP DC
7	14mm Bottom Cable Entry Exp. AC
7D	14mm Bottom Cable Entry Exp. DC
8	18mm Bottom Cable Entry Exp.AC
8D	18mm Bottom Cable Entry Exp. Dc

10	FEATURES
-	W/O Mor
M	Turn Mor
P	Push Mor
M1	Push & Turn Mor
P1	Pull Mor
3	3 Position Mor

12	CONFIGURATION
-	REGULAR
C1	CONFIG 1
...	...
C9	CONFIG 9
CA	CONFIG 10
CB	CONFIG 11

13	VERSION
-	VERSION 0
V1	VERSION 1
...	...
V9	VERSION 9
VA	VERSION 10

11	ORIFICE IN MM	
100	10mm ORIFICE	016 1.6mm ORIFICE
120	12mm ORIFICE	018 1.8mm ORIFICE
152	15.2mm ORIFICE	020 2mm ORIFICE
170	17mm ORIFICE	022 2.2mm ORIFICE
180	18mm ORIFICE	025 2.5mm ORIFICE
200	20mm ORIFICE	028 2.8mm ORIFICE
250	25mm ORIFICE	030 3mm ORIFICE
300	30mm ORIFICE	031 3.1mm ORIFICE
005	0.5mm ORIFICE	035 3.5mm ORIFICE
006	0.6mm ORIFICE	040 4mm ORIFICE
007	0.7mm ORIFICE	045 4.5MM ORIFICE
008	0.8mm ORIFICE	050 5mm ORIFICE
009	0.9mm ORIFICE	060 6mm ORIFICE
010	1mm ORIFICE	064 6.4mm ORIFICE
012	1.2mm ORIFICE	070 7mm ORIFICE
013	1.3mm ORIFICE	080 8mm ORIFICE
015	1.5mm ORIFICE	

DAS-DA104E031
1/4" 2 WAY DIRECT ACTING ALUMINIUM-NITRILE-0 TO 10 Bar
-BSP-NC-14MM AC-3.1MM ORIFICE

Note : The above chart is for identification purposes only, and it may not be possible to make all combinations for the above chart.

DAC - SERIES DIRECT ACTING SOLENOID VALVE MODEL CHART

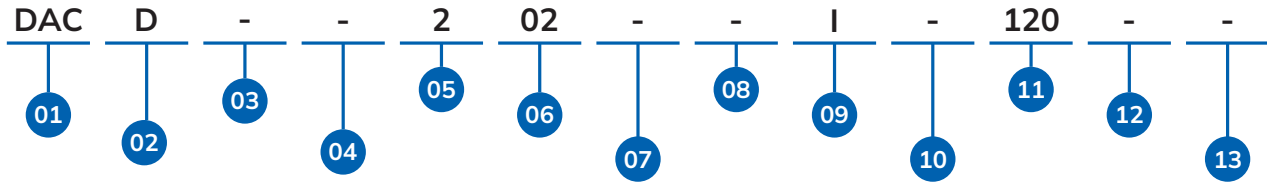

01	SERIES	05	PORT SIZE	07	PORT CONNECTION	08	VALVE POSITION	10	FEATURES	12	CONFIGURATION
DAC		-	1/8"	-	BSP	-	NC	-	W/O Mor	-	REGULAR
1		1	1/4"	N	NPT	Z	NO	M	Turn Mor	C1	CONFIG 1
2		2	1/2"	P	BSPT	Y	Universal	P	Push Mor
3		3	3/4"	R1	Namur Bsp	D1	Diverting	M1	Push & Turn Mor	C9	CONFIG 9
7		7	3/8"	T1	Namur Npt	X	Mixing	P1	Pull Mor	CA	CONFIG 10
8		8	M14	2	Manifold	R	BI directional NC	3	3 Position Mor	CB	CONFIG 11
O		O	Manifold Mount	4	UNF	S	BI directional NO				
				9	MM						
02	PRODUCT TYPE	06		PRESSURE RANGE		09	COIL DIA	11			
D	2 Way	00	0 to 350 Mbar	21	0 to 20 Bar	A	8mm AC	ORIFICE IN MM			
T	3 Way	01	0 to 500 Mbar	26	0 to 200 MBar	B	8mm DC	100	10mm ORIFICE	016	1.6mm ORIFICE
		02	0 to 2 Bar	30	0 to 1.5 Bar	C	10mm AC	120	12mm ORIFICE	018	1.8mm ORIFICE
		03	0 to 7 Bar	31	0 to 6 Bar	D	10mm DC	152	15.2mm ORIFICE	020	2mm ORIFICE
		04	0 to 10 Bar	32	0 to 8 Bar	E	14mm AC	170	17mm ORIFICE	022	2.2mm ORIFICE
		05	0 to 16 Bar	34	0 to 10 PSI	F	14mm DC	180	18mm ORIFICE	025	2.5mm ORIFICE
		07	0.5 to 8.5 Bar	38	0 to 12 Bar	G	14mm FLP AC	200	20mm ORIFICE	028	2.8mm ORIFICE
		11	0 to 25 Bar	39	0 to 150 Mbar	H	14mm FLP DC	250	25mm ORIFICE	030	3mm ORIFICE
		12	0 to 150 Bar	42	0 to 13 Bar	I	18mm AC	300	30mm ORIFICE	031	3.1mm ORIFICE
		13	0 to 4 Bar	43	0 to 15 Bar	J	18mm DC	005	0.5mm ORIFICE	035	3.5mm ORIFICE
		14	0 to 3 Bar	44	0 to 18 Bar	K	30mm AC	006	0.6mm ORIFICE	040	4mm ORIFICE
		15	0 to 1 Bar	46	0 to 21 Bar	L	30mm DC	007	0.7mm ORIFICE	045	4.5mm ORIFICE
		17	0 to 60 Bar	47	0 to 35 Bra	M	28mm	008	0.8mm ORIFICE	050	5mm ORIFICE
		18	0 to 40 Bar	48	20 to 110 Bar	O	5.5mm DC	009	0.9mm ORIFICE	060	6mm ORIFICE
		19	0 to 5 Bar	52	-1 to 1 Bar	Q	5mm DC	010	1mm ORIFICE	064	6.4mm ORIFICE
		20	0 to 100 Bar			T	12mm AC	012	1.2mm ORIFICE	070	7mm ORIFICE
						U	12mm DC	013	1.3mm ORIFICE	080	8mm ORIFICE
						V	18mm FLP AC	015	1.5mm ORIFICE		
						W	18mm FLP DC				
						5	14mm SS FLP AC				
						6	14mm SS FLP DC				
						7	14mm Bottom Cable Entry Exp. AC				
						7D	14mm Bottom Cable Entry Exp. DC				
						8	18mm Bottom Cable Entry Exp.AC				
						8D	18mm Bottom Cable Entry Exp.AC				
03	BODY MATERIAL	13		VERSION							
-	CF8	-	VERSION 0								
M	CF8M	V1	VERSION 1								
B	Brass Forge								
C	CF3M	V9	VERSION 9								
		VA	VERSION 10								

DAC-D202I120
 1/2" 2 WAY DIRECT ACTING CF8-NITRILE-0 TO 2 Bar-
 BSP-NC-18MM AC-12MM ORIFICE

Note : The above chart is for identification purposes only, and it may not be possible to make all combinations for the above chart.



Valve Specifications

Model No. :	DAR-D6J146NV035C1	DAR-D6J144NZV030C1
Valve Position :	Normally Close	Normally Open
Type :	2/2 Direct Acting	
Orifice :	3.5 mm	3 mm
Pressure :	0 - 21 bar	0 - 18 bar
Body Material :	SS 316	
Port Connection :	1/4" NPT(F)	
Media :	Petrol/ Diesel/ SKO/ HSD	
Ambient Temperature :	-20°C to 70°C	
Seal Material :	Viton GLT	
Media Temp. :	-30°C to 230°C	

Coil Specification

Operating Voltage :	230V AC
Power Consumption :	15W
Coil Features :	High Reliability Unaffected by Voltage Surges. Easy coil changes coil lockable in 4X90 position or freely movable in between as require.
Coil Housing :	IP65 Epoxy square coil, IP65 Metallic round enclosure, IP67 Flameproof enclosure, IP68 Weatherproof enclosure.

Port Connection

1 - Output, 2 - Input

Valve Model No.	Function	Symbol
DAR-D6J146NV035C1	Single Solenoid Spring Return	
DAR-D6J144NZV030C1	Single Solenoid Spring Return	

Features

- Bubble tight shut off
- Mounts in any position
- Vibration resistance up to 9g
- Suitable for high speed cycling
- Speed up to 600 cycles/ min
- Life >10 million cycles

Dimension Drawing (All dimensions in mm)

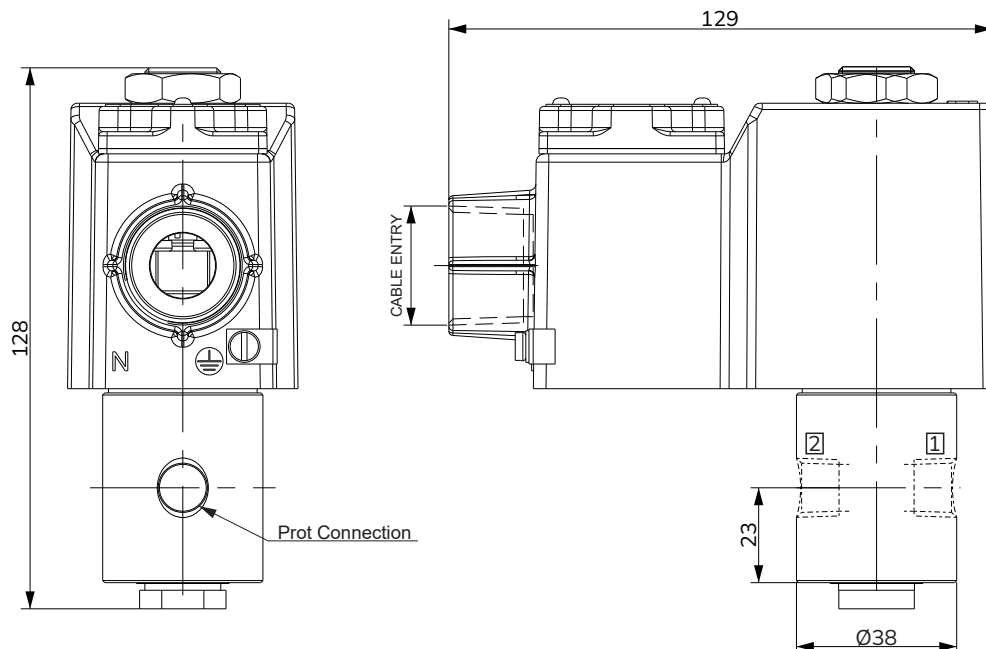

DAR - SERIES DIRECT ACTING ROUND TYPE SOLENOID VALVE MODEL CHART

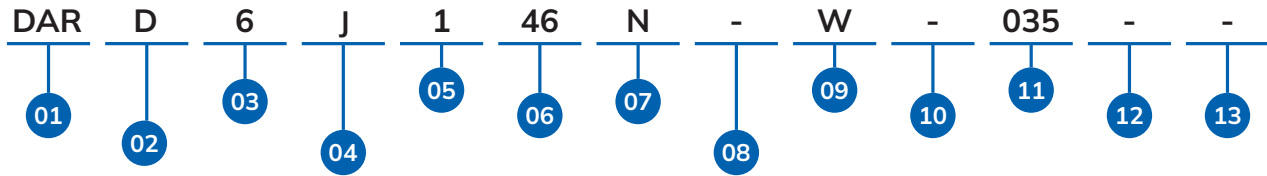

01	SERIES
	DAR

02	PRODUCT TYPE
D	2 Way

03	BODY MATERIAL
-	SS304
6	SS316

04	SEAL MATERIAL
-	Nitrile
J	Viton GLT
E	EPDM
V	Viton
F	SPL Viton

05	PORT SIZE
1	1/4"

06	PRESSURE RANGE
44	0 to 18 Bar
46	0 to 21 Bar

07	PORT CONNECTION
-	BSP
N	NPT

08	VALVE POSITION
-	NC
Z	NO

09	COIL DIA
V	18mm FLP AC
W	18mm FLP DC
7	14mm Bottom Cable Entry Exp. Ac
7D	14mm BOTTOM Cable ENTRY EXP. AC
8	18mm Bottom Cable Entry Exp.ac
8D	18mm Bottom Cable Entry Exp. Dc

10	FEATURES
-	W/O MOR

11	ORIFICE IN MM
030	3mm Orifice
035	3.5mm Orifice

12	CONFIGURATION
-	REGULAR
C1	CONFIG 1
C2	CONFIG 2
C3	CONFIG 3
⋮	⋮
C9	CONFIG 9
CA	CONFIG 10
CB	CONFIG 11

13	VERSION
-	VERSION 0
V1	VERSION 1
V2	VERSION 2
V3	VERSION 3
⋮	⋮
V9	VERSION 9
VA	VERSION 10
VB	VERSION 11

DAR-D6J146NW035
1/4" 2 WAY DIRECT ACTING SS316-VITON GLT-0 TO 21 Bar-NPT-NC-18MM FLP DC-3.5MM ORIFICE

Note : The above chart is for identification purposes only, and it may not be possible to make all combinations for the above chart.



Specifications

Port :	1/2" - BSP Thread	Operating Voltage :	230V AC
End Connection :	Screwed	Power Consumption :	10W
Body Material :	CF8	Coil Features :	High Reliability Unaffected by Voltage Surges. Easy coil changes coil lockable in 4X90 position or freely movable in between as require.
Diaphragm :	Nitrile (NBR)	Coil Housing :	Metallic round enclosure
Media Temp :	-30°C to 90°C	Other Specification Data :	Available on request
Circumstance Temp :	-10°C to 70°C		
Media :	Air, Water, Chemical, Gas		
Main Features :	Internal parts are in superior corrosion resistance steel.		

NOTE: Use of filter in the inlet port is recommended.
Specification may change without prior notice.

Features

- Compact Design
- High Flow Rate (Minimal Flow)
- Food Grade compatible
- Angle Type Outlet Design

Technical Data

Valve Model No.	Coil Model No.	Body Material	Pipe (Inch)	Orifice (mm)	Min. Operating Pressure Kg/cm ²	Max. Operating Pressure Kg/cm ²	Seal & Diaphragm Material	Flow Factor Kv m ³ / hr
DAA-D2E100	RAI10L	CF8	1/2"	10	0	1	Nitrile (NBR)	1.2

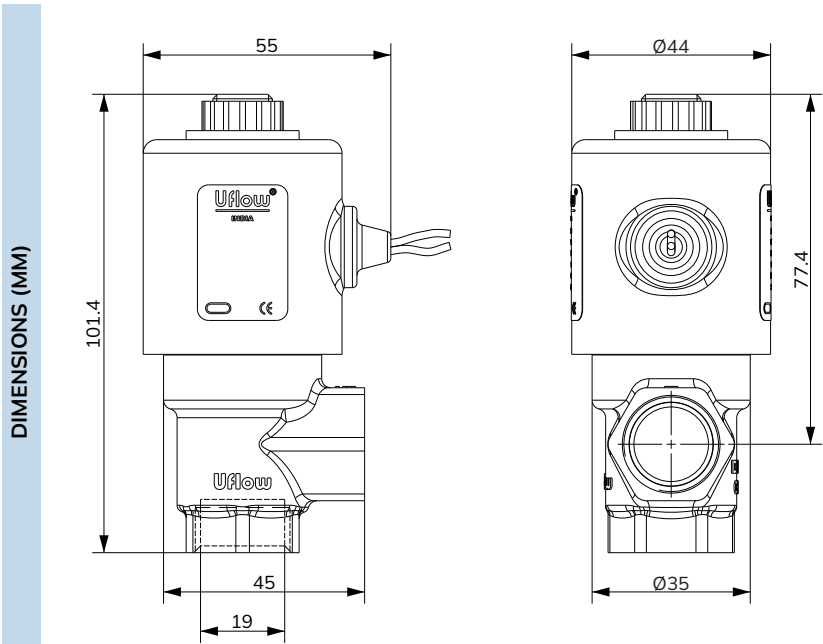

Flow Path Diagram

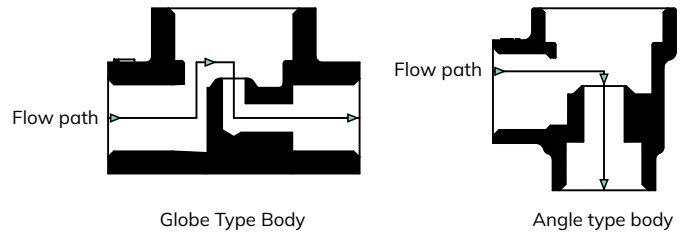

"An angle-type body delivers superior flow efficiency when compared to a globe-type body."

* All dimensions are approx

2 WAY DIRECT ACTING ANGLE TYPE VALVE MODEL IDENTIFICATION CHART

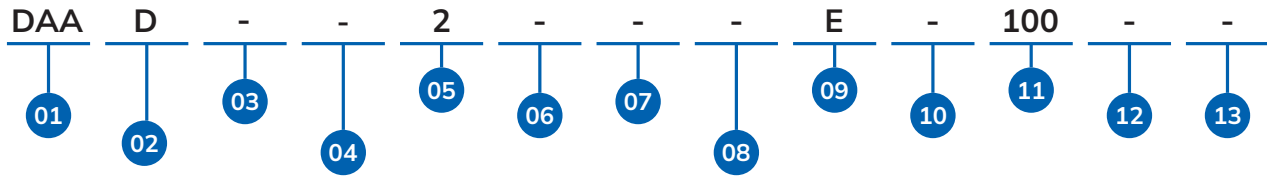

01	SERIES
DAA	DAA

02	PRODUCT TYPE
D	2 Way Direct Acting Angle Type

03	BODY MATERIAL
-	CF8
M	CF8M
C	CF3M

04	SEAL MATERIAL
-	Nitrile
E	EPDM
V	Viton
S	Silicone
F	SPL Viton

05	PORT SIZE
2	1/2"

06	PRESSURE RANGE
-	0 - 1 Bar

07	PORT CONNECTION
-	BSP
N	NPT

08	VALVE POSITION
-	NC

09	COIL DIA
E	14mm AC
F	14mm DC
G	14mm FLP AC
H	14mm FLP DC
5	14mm SS FLP AC
6	14mm SS FLP DC
7	14mm Bottom Cable Entry Exp. Ac
7D	14mm Bottom Cable Entry Exp. Ac
8	14mm Bottom Cable Entry Exp. Ac
8D	14mm Bottom Cable Entry Exp. AC

10	FEATURES
-	W/O MOR

11	ORIFICE IN MM
100	10MM Orifice

12	CONFIGURATION
-	REGULAR
C1	CONFIG 1
C2	CONFIG 2
C3	CONFIG 3
...	...
C9	CONFIG 9
CA	CONFIG 10
CB	CONFIG 11

13	VERSION
-	VERSION 0
V1	VERSION 1
V2	VERSION 2
V3	VERSION 3
...	...
V9	VERSION 9
VA	VERSION 10
VB	VERSION 11

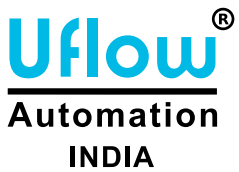

DAA-D2E100
 1/2" 2 WAY DIRECT ACTING ANGLE BODY CF8-NITRILE-0 TO 1 BAR-BSP-NC-14MM AC-W/O MOR-10MM ORIFICE

Note: The above chart is for identification purposes only, and it may not be possible to make all combinations for the above chart.

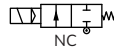

Specifications

Port :	½" - BSP Thread
End Connection :	Screwed
Body Material :	Nylon GF
Diaphragm :	FPM
Media Temp :	5°C to 50°C
Circumstance Temp :	-10°C to 70°C
Media :	Water, Liquid Media, Gaseous Media
Main Features :	Internal Parts are in superior corrosion resistance steel. and Without Mor

Operating Voltage :	12V DC	24V DC	24V AC	230V AC
Power Consumption :	10W	11W	10W	10W

Coil Features : High Reliability Unaffected by Voltage Surges. Easy coil changes coil lockable in 4X90 position or freely movable in between as require.

Coil Housing : IP65 Epoxy square coil, IP65 Metallic round enclosure.

Other Specification Data : Available on Request

- Available for vacuum application upto 450mm Hg

NOTE: Use of filter in the inlet port is recommended. Specification may change without prior notice.

Technical Data

Valve Model No.	Body Material	Pipe (Inch)	Orifice (mm)	Min. Operating Pressure PSI	Max. Operating Pressure PSI	Seal & Diaphragm Material	Flow Factor Kv m ³ / hr
SF251F080	Nylon GF	½"	8	0	20	FPM	1

DIMENSIONS (MM)

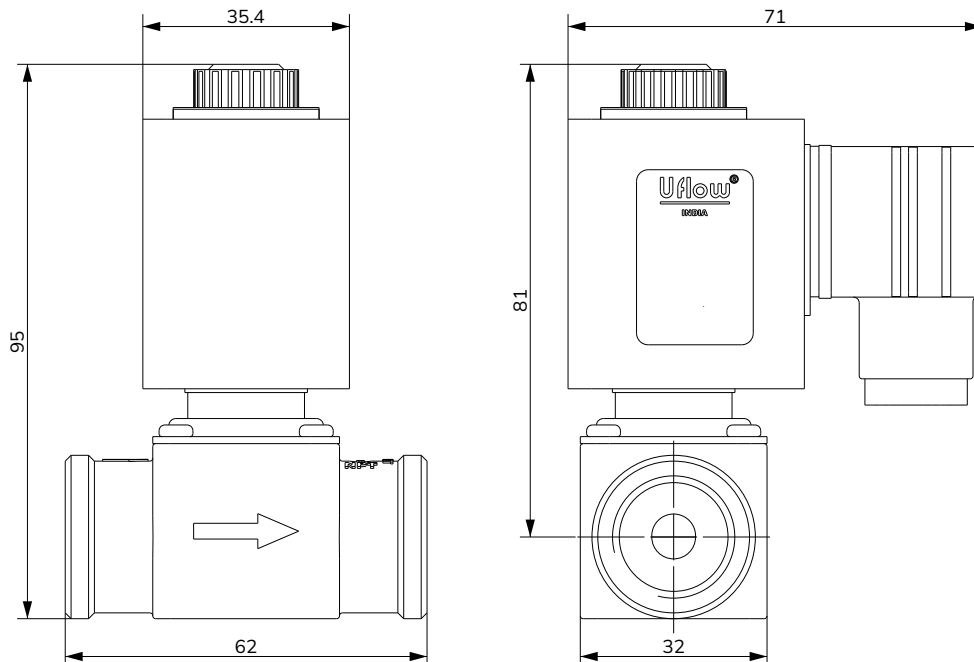

* All dimensions are approx

2 WAY DIRECT ACTING MEDIA SEPARATED VALVE MODEL IDENTIFICATION CHART

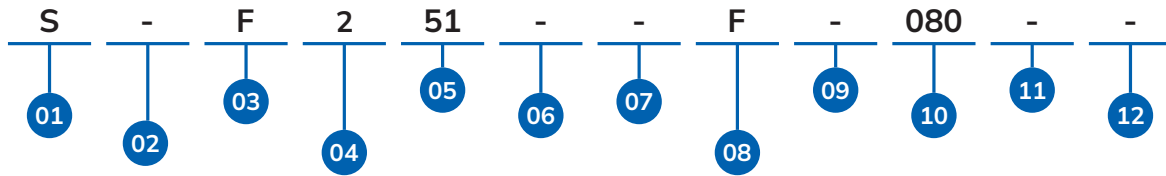

01 PRODUCT TYPE

S	2 Way Direct Acting Media Separated
M	3 Way Direct Acting Media Separated

02 BODY MATERIAL

-	Nylon GF
Y	Nylon
M	CF8M

03 SEAL MATERIAL

-	Nitrile
F	FPM
S	Silicone
E	EPDM

04 PORT SIZE

2	1/2"
0	1/8"
1	1/4"
7	3/8"

05 PRESSURE RANGE

51	0 - 20 PSI
04	0 - 10 Bar

06 PORT CONNECTION

-	BSP
N	NPT
P	BSPT

07 VALVE POSITION

-	NC
U	Universal
C	NC BELOW

08 COIL DIA

E	14MM AC
F	14MM DC
G	14MM FLP AC
H	14MM FLP DC
Z	13.5MM DC
J	18MM DC
5	14MM SS FLP AC
6	14MM SS FLP DC

09 FEATURES

-	W/O MOR
3	3 Position MOR

10 ORIFICE IN MM

080	8MM Orifice
020	2MM Orifice
050	5MM Orifice
010	1MM Orifice

11 CONFIGURATION

-	REGULAR
C1	CONFIG 1
C2	CONFIG 2
C3	CONFIG 3
⋮	⋮
C9	CONFIG 9
CA	CONFIG 10
CB	CONFIG 11

12 VERSION

-	VERSION 0
V1	VERSION 1
V2	VERSION 2
V3	VERSION 3
⋮	⋮
V9	VERSION 9
VA	VERSION 10
VB	VERSION 11

SF251F080
1/2" 2 WAY DIRECT ACTING MEDIA SEPARATED Nylon GF-FPM-0 TO 20
PSI-BSP-NC-14MM DC-8MM ORIFICE

Note: The above chart is for identification purposes only, and it may not be possible to make all combinations for the above chart.

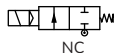

Specifications

Port :	½" - BSP Thread			
End Connection :	Screwed			
Body Material :	CF8			
Diaphragm :	Nitrile (NBR)	EPDM	Viton (FKM)	SPL. Viton
Media Temp :	-30°C to 90°C	-10°C to 140°C	-10°C to 180°C	-10°C to 180°C
Circumstance Temp :	-10°C to 70°C			
Media :	Air, Water, Chemical, Gas			
Main Features :	Internal Parts are in superior corrosion resistance steel			

Operating Voltage :	230AC
Power Consumption :	9W
Coil Features :	High Reliability Unaffected by Voltage Surges. Easy coil changes coil lockable in 4X90 position or freely movable in between as require.
Coil Housing :	IP65 Epoxy square coil
Timing :	Cycle : 1 min to 120 min Adjustable Drain : 1 sec to 25 sec Adjustable

Features

- Designed specially to drain sludge and rust laden condensate
- Reliable all digital electronic circuitry
- ON and OFF timing adjustable

Technical Data

Valve Model No.	Timer Model No.	Body Material	Pipe (Inch)	Orifice (mm)	Min. Operating Pressure Kg/cm ²	Max. Operating Pressure Kg/cm ²	Seal & Diaphragm Material	Flow Factor Kv m ³ / hr
AD2E015	T11A	CF8	½"	1.5	0	16	NBR / EPDM / Viton / SPL. Viton	0.07
AD2E030	T11A	CF8	½"	3	0	16	NBR / EPDM / Viton / SPL. Viton	0.20

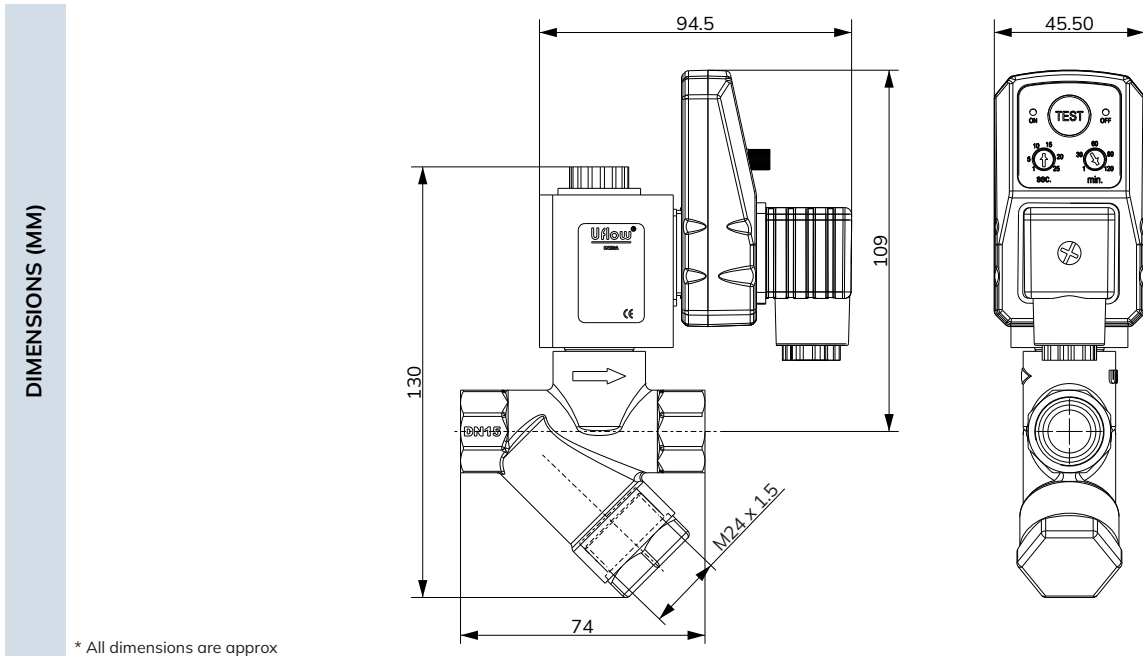

* All dimensions are approx

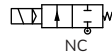

Specifications

Port :	½" - BSP (F)	Operating Voltage :	230V AC	12V DC	24V DC
End Connection :	Screwed	Power Consumption :	09W	09W	09W
Body Material :	CF8	Coil Features :	High Reliability Unaffected by Voltage Surges. Easy coil changes coil lockable in 4X90 position or freely movable in between as require.		
Diaphragm :	Nitrile (NBR)	Coil Housing :	IP-65 Epoxy square coil		
Media Temp :	-30°C to 90°C	Timing :	Cycle : 1 min to 120 min Adjustable Drain : 1 sec to 25 sec Adjustable		
Circumstance Temp :	-10°C to 70°C				
Media :	Air, Water, Chemical, Gas				
Main Features :	Internal Parts are in superior corrosion resistance steel				

Features

- ✓ Easy to mount at all locations.
- ✓ On / Off timing adjustable.
- ✓ Maintains and cleans drain valves without removing from.
- ✓ Condensate discharging is no more problem.
- ✓ Large orifice for effective drain of dust and condensate.
- ✓ Design specially to drain sludge and rust laden condensate.

Technical Data

Valve Model No.	Timer Model No.	Coil Model No.	Body Material	Pipe (Inch)	Orifice (mm)	Pilot Pressure Kg/cm ²	Operating Pressure Range Kg/cm ²	Seal & Diaphragm Material	Flow Factor Kv m ³ / hr
AP2E125	T11A	MAI09SV1	CF8	½"	12.5	4	0-16	Nitrile (NBR)	0.7

DIMENSIONS (MM)

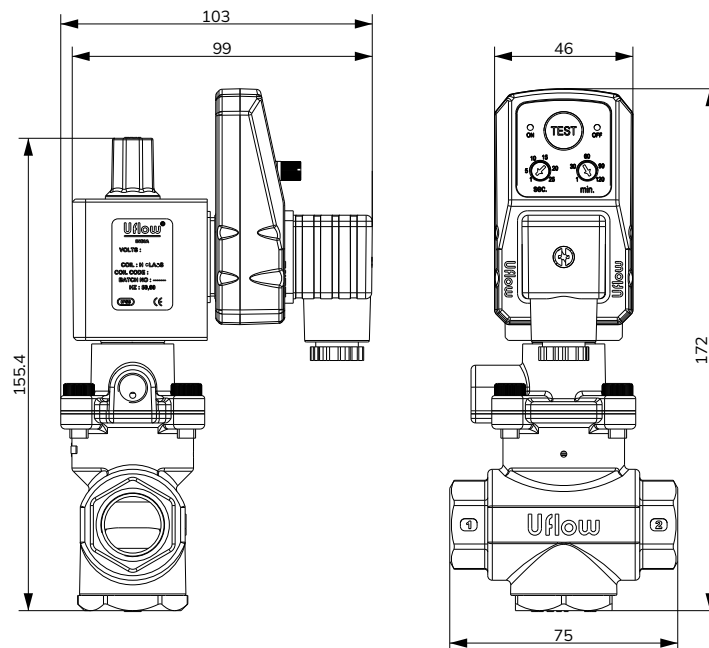

* All dimensions are approx

AUTO DRAIN VALVE MODEL CHART

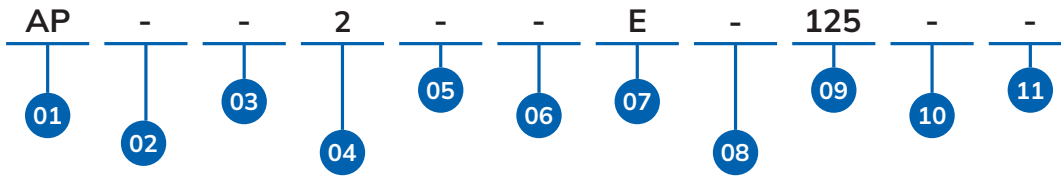

01 PRODUCT TYPE

AD	Auto Drain 2 Way Direct Acting
AP	Auto Drain 2 Way Pilot Operated

02 BODY MATERIAL

-	CF8
M	CF8M

03 SEAL MATERIAL

-	Nitrile
E	EPDM
V	Viton
F	SPL. Viton
S	Silicone

04 PORT SIZE

2	1/2"
---	------

05 PRESSURE RANGE

-	0 - 16 BAR
04	0 - 10 Bar

06 PORT CONNECTION

-	BSP
---	-----

07 COIL DIA

E	14MM
F	14MM FLP
N	14MM SS FLP
7	14mm Bottom Cable Entry Exp. Ac
7D	14mm Bottom Cable Entry Exp. Dc
8	14mm Bottom Cable Entry Exp. Dc
8D	18mm Bottom Cable Entry Exp. Dc

08 FEATURES

-	W/O MOR
S	With Strainer

09 ORIFICE IN MM

015	1.5mm Orifice
013	1.3mm Orifice
030	3mm Orifice
125	12.5mm Orifice

10 CONFIGURATION

-	REGULAR
C1	CONFIG 1
C2	CONFIG 2
C3	CONFIG 3
⋮	⋮
C9	CONFIG 9
CA	CONFIG 10
CB	CONFIG 11

11 VERSION

-	VERSION 0
V1	VERSION 1
V2	VERSION 2
V9	VERSION 3
VA	⋮
VB	VERSION 9
	VERSION 10
	VERSION 11

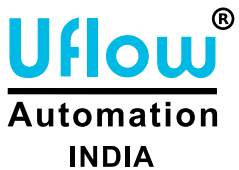

AP2E125
1/2" AUTO DRAIN 2 WAY PILOT OPERATED CF8-NITRILE-0 TO 16 Bar-BSP-NC-14MM-12.5MM ORIFICE

Note: The above chart is for identification purposes only, and it may not be possible to make all combinations for the above chart.

TIMER CIRCUIT MODEL CHART

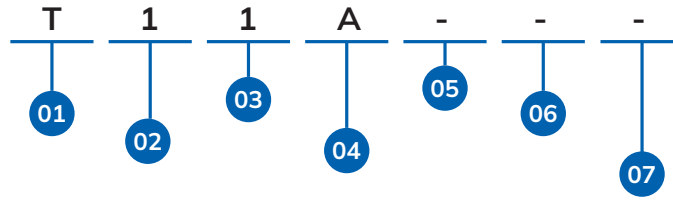

01	PRODUCT TYPE
T	Timer Circuit

02	CYCLE TIME
1	1 to 120 min

03	DRAIN TIME
1	1 to 25 Sec

04	VOLTAGE
A	230V AC
G	24V DC

05	ELECTRICAL CONNECTION
-	DIN 43650 MICRO

06	CONFIGURATION
-	REGULAR
C1	CONFIG 1
C2	CONFIG 2
C3	CONFIG 3
⋮	⋮
C9	CONFIG 9
CA	CONFIG 10
CB	CONFIG 11

07	VERSION
-	VERSION 0
V1	VERSION 1
V2	VERSION 2
V3	VERSION 3
⋮	⋮
V9	VERSION 9
VA	VERSION 10
VB	VERSION 11

T11A
TIMER 1 to 120 MIN 1 to 25 SEC 230V AC DIN 43650 MICRO

Note: The above chart is for identification purposes only, and it may not be possible to make all combinations for the above chart.

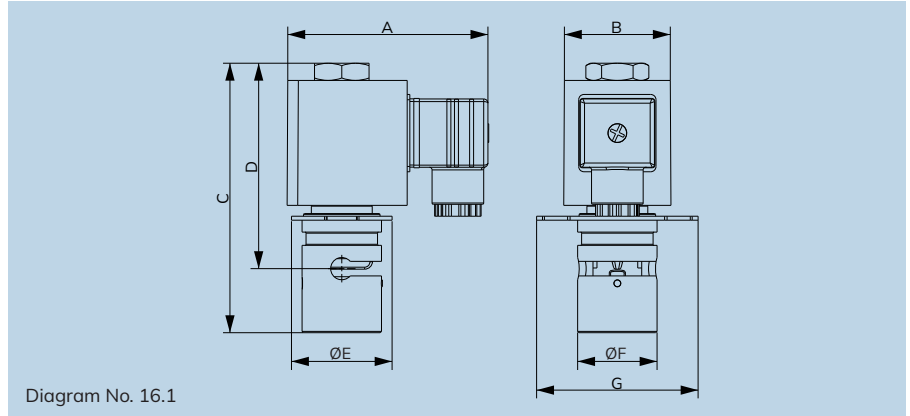

Diagram No. 16.1

Specifications

Body :	Aluminum		
Internal Parts :	Stainless Steel		
Sealing :	Polyamide		
Seats, Core Tube, Springs	Stainless Steel		
Operating Voltage :	12V DC	24V DC	230V AC
Power Consumption :	20W	20W	20W
Application :	Water, Food, Gas, Medicine, Hospital & Health, Petro Chemistry		
Coil Housing :	Epoxy Square Coil		
Coil Features :	High Reliability Unaffected by Voltage Surges. Easy coil changes coil lockable in 4X90 position or freely movable in between as require.		
Other Specification Data :	Available on Request		

Dimension

All dimensions are approx.

Model No.	Diagram No.	A	B	C	D	ØE	ØF	F
P08Y	16.1	76	40	102	78	38	30	61
P08ZY	16.1	76	40	102	88	38	30	61

Features

- There are different models for different tube diameter.
- The tubing is the only material in contact with the fluid.
- Bobbin up in a vertical position should be preferred.
- Fluid not in contact with metal parts.
- The differential pressure of this product is 0 bar
- Solenoid valves must be used with filtered fluids
- Compact and low weight valve enabling easy and quick installation.
- Stiffness of Hose: Max. 55 Shore A
- Usage Areas : Dialysis Machines, Pharmaceutical Industry, Medical Laboratories, Food Industry, Bioreactors, Blood Transf Unit, Tissu Transplantation Units.

Advantages

- Low Pressure Loss: Pinch valves at are very few pressure loss. This low pressure system reason it is preferred to perform the flow without causing further loss pressure.
- Use Amenities Containing Particulate in Fluids: Pinch valves use in streams containing small particles is an advantage. small parts such as sand can lead to clogging or orifice solenoid coil blubbering normal valves. The use of pinch valves is an advantage in such cases.
- Ease of change: In case of any malfunction in a very easy way pinch valves even the is possible to provide changes without the need stopping the flow.
- Being the Just Fow in Contact With Hosepipe: Is no material or seal outside Hose in pinch valves to be in contact with the fluid. This feature is of great importance for chemicals that are react with a hygienic risks flow or

Technical Data

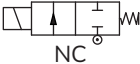
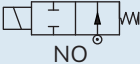
Symbol	Model No.	Tubings		Min. Tubings Wall Thickness	Max. Operating Pressure Kg/cm ²
		Inside Diameter	Outside Diameter		
 NC	P09Y	6	9	1.5	0.5
	P09ZY	6	9	1.5	0.5
	P08Y	5	8	1.5	0.5
	P08ZY	5	8	1.5	0.5
 NO	P07Y	4	7	1.5	0.5
	P07ZY	4	7	1.5	0.5
	P06Y	3	6	1.5	0.5
	P06ZY	3	6	1.5	0.5

PINCH TYPE SOLENOID VALVE MODEL IDENTIFICATION CHART

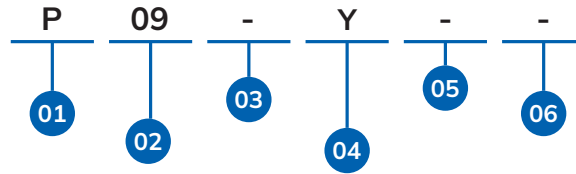

01	PRODUCT TYPE
P	2 Way Pinch Valve

02	BODY MATERIAL
09	Applicable Tubing OD 9MM
08	Applicable Tubing OD 8MM
07	Applicable Tubing OD 7MM
06	Applicable Tubing OD 6MM
04	Applicable Tubing OD 4MM

03	VALVE POSITION
-	NC
Z	NO

04	COIL DIA
X	16mm AC
Y	16mm DC
7	14mm Bottom Cable Entry Exp. AC
7D	14mm Bottom Cable Entry Exp. AC
8	14mm Bottom Cable Entry Exp. AC
8D	18mm Bottom Cable Entry Exp. DC

05	CONFIGURATION
-	REGULAR
C1	CONFIG 1
C2	CONFIG 2
C3	CONFIG 3
⋮	⋮
C9	CONFIG 9
CA	CONFIG 10
CB	CONFIG 11

06	VERSION
-	VERSION 0
V1	VERSION 1
V2	VERSION 2
V3	VERSION 3
⋮	⋮
V9	VERSION 9
VA	VERSION 10
VB	VERSION 11

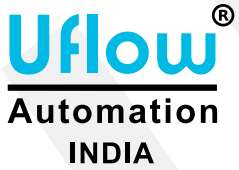

P09Y
2 WAY PINCH VALVE APPLICABLE TUBING OD 9MM
Aluminium-NC-16MM DC

Note : The above chart is for identification purposes only, and it may not be possible to make all combinations for the above chart.



SECTION VIEW

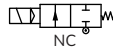

Valve Specifications

Port :	½" (Available in BSP / BSPT / NPT)			
End Connection :	Screwed			
Body Material :	Brass Forge			
Seal Material :	Nitrile (NBR)	EPDM	Viton (FKM)	PTFE
Media Temp :	-30°C to 90°C	-10°C to 140°C	-10°C to 180°C	-10°C to 180°C
Circumstance Temp :	-10°C to 70°C			
Media :	Air, Water, Chemical, Gas, Oil, Diesel, Kerosene, LPG.			
Main Features :	Internal Parts Are In Superior Corrosion Resistance Steel.			

Actuator Specifications

Cover :	Aluminium
Control Plate :	Aluminium
Working Pressure	3.5 - 7 Bar
Seal Material	Nitrile

NOTE: Use of filter in the inlet port is recommended.
Specification may change without prior notice.

Technical Data

Valve Model No.	Body Material	Pipe (Inch)	Orifice (mm)	Min. Operating Pressure Kg/cm ²	Max. Operating Pressure Kg/cm ²	Seal & Diaphragm Material	Flow Factor Kv m ³ / hr
C205	Brass	½"	12	0	16	NBR / EPDM / VITON / PTFE	2.5

DIMENSIONS (MM)

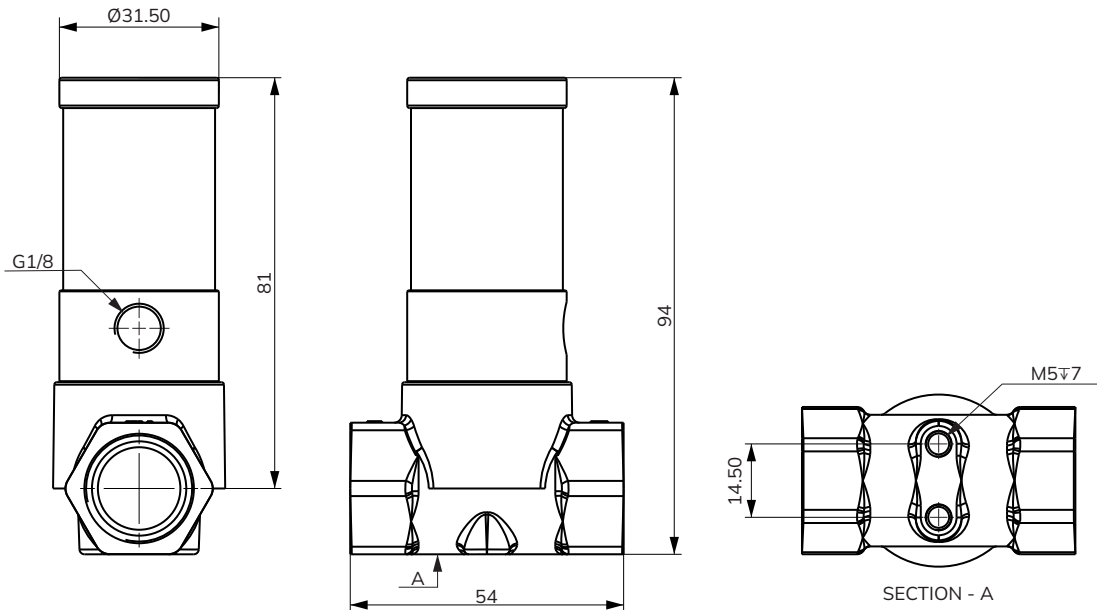

* All dimensions are approx

2 WAY CONTROL VALVE WITH ALUMINUM OPERATOR MODEL IDENTIFICATION CHART

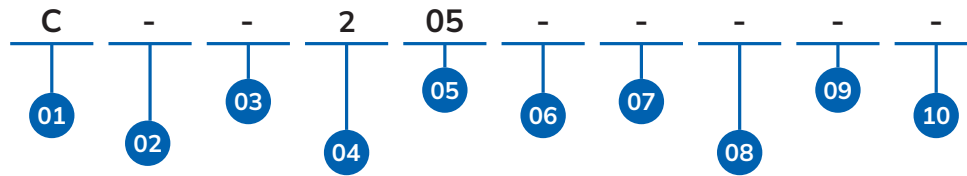

01	PRODUCT TYPE
C	2 Way Control Valve

02	Body Material
-	BRASS

03	Seal Material
-	NITRILE
E	EPDM
V	VITON
F	SPL. VITON

04	Port Size
2	1/2"

05	Pressure
04	0 - 10 Bar
05	0 - 16 Bar

06	ACTUATOR SIZE
-	25 Clean

07	PORT CONNECTION
-	BSP
P	BSPT
N	NPT

08	VALVE POSITION
-	NC Above
Z	NO Above
C	NC Below

08	OPERATOR
-	Aluminum

09	CONFIG
-	REGULAR
C1	CONFIG 1
C2	CONFIG 2
C3	CONFIG 3
⋮	⋮
C9	CONFIG 9
CA	CONFIG 10
CB	CONFIG 11

10	VERSION
-	VERSION 0
V1	VERSION 1
V2	VERSION 2
V3	VERSION 3
⋮	⋮
V9	VERSION 9
VA	VERSION 10
VB	VERSION 11

C205
1/2" 2 WAY CONTROL VALVE ALUMINUM OPERATOR BRASS-
NITRILE-0 TO 16 Bar-25 CLEAN-BSP-NC ABOVE

Note: The above chart is for identification purposes only, and it may not be possible to make all combinations for the above chart.



**SOLENOID COIL
SERIES**

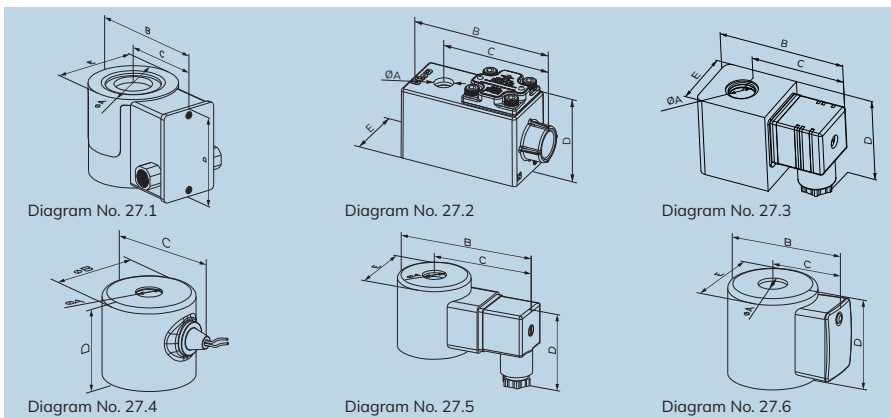

Specifications

Port :	IP65 Epoxy moulded with led din connector, Metallic round shape with lead wire, IP67 Flame proof junction box, IP68 weather proof metallic round enclosure, IP67 Weather proof junction box, IP67 Explosion proof junction box with bottom cable entry, IP67 Explosion proof junction box with horizontal cable entry				
Coil Bore Diameter :	5mm, 8mm, 10mm, 12mm, 14mm, 16mm, 18mm, 28mm, 30mm				
Class :	H-Class, Weather Proof IP68, Flame Proof IP67				
Voltage :	24AC	110AC	230AC	12DC	24DC
Watt :	9W	8W / 30W	8W / 17W / 30W	10W / 6W	11W / 6W
Duty :	Non Latching - Continues Duty - 100%, Latching - Required pulse in millisecond.				
Main Features :	Surge Suppressor for High Wattage Coil. 90% Power saver series also available, Latching Coil.				
Latching Coil Benefits :	<p>Remote or Battery operated application</p> <p>A situation where a valve needs to be open/actuated for an extended period of time</p> <p>Continuous operation of solenoid coil generates heat, and certain portion of it get dissipated into the media flowing through the valve, hence to avoid such heat generation and dissipation, Latching coil is recommended.</p> <p>End connections in Flame Proof Junction Box , Weather Proof Junction Box are available in</p> <ul style="list-style-type: none"> - 1/2" NPT - M20 X 1.5 				

Dimension (All dimensions in mm)

All Dimensions are approx.

Type	Diagram No.	A	B	C	D	E
Epoxy Moulded Round Coil	27.1	30.5	105	69	75	71
Flame proof Junction Box IP67	27.2	14.5	112	86	63	52
Epoxy Moulded With LED Din Connector	27.3	14.5	71	53	49	36
Epoxy Moulded With LED Din Connector	27.3	10.3	65	52	46	26
Metallic Round Enclosure With Lead Wire	27.4	14.5	44	57	48	-
Metallic Round Enclosure With Lead Wire	27.4	10.3	28	34	30	-
Metallic Round Enclosure LED Din Connector	27.5	14.5	85	63	50	44
Epoxy Moulded With LED Din Connector	27.3	18.5	84	57	58	54
Metallic Round Enclosure With Lead Wire	27.4	18.5	50	62	61	-
Metallic Round Enclosure Power Saver	27.6	14.5	61	39	49	44
Weather Proof Junction Box IP67	27.2	18.5	130	102	67	55
Weather Proof Round Enclosure	27.4	12	29	-	48	-

- Metallic Round Enclosure Weather proof coils complies as per IS/IEC-60529-2001 (Approved by ERDA) (IP-68).
- Weather proof junction Box coils complies as per IS/IEC-60529-2001 (Approved by ERDA) (IP-67).
- Flame Proof Junction Box conforming as per Is/IEC-60079-1:2007 (Approved by ELCA).
- Coils are suitable for IIC Atmosphere Condition (Zone 1&2 Gas Group).
- Flame Proof Series are followed under BIS.
- For Flame Proof Condition Working Environment Coils are licensed under PESO.
- TRCU certified product available on request
- CE certified

We Are Introducing New Power Saver Series (VA Series) Served by Our R&D Department, This New Latest Technology Saves Up to 90% of Power.

BENEFITS:

- Reduce Battery Drain
- Reduce Wiring Cost
- Reduce Temperature Rise
- Low Wattage
- Energy Savings
- Improve Valve Performance at High Pressure

SOLENOID COIL MODEL IDENTIFICATION CHART

PRODUCT TYPE		VOLTAGE	COIL BORE	WATTAGE	CONNECTION	CONFIGURATION	VERSION
R	ROUND SOLENOID	A 230V AC	F 08MM	00 00.00	S SOCKET	BLANK	- VERSION 0
M	EPOXY SOLENOID	B 24V AC	G 10MM	01 01.00	L LEAD WIRE	C1	V1 VERSION 1
W	WEATHER PROOF SOLENOID	C 42V AC	I 14MM	02 02.00	H ½" NPT	C2	V2 VERSION 2
F	FLAME PROOF JUNCTION BOX	D 48V AC	K 18MM	03 03.00	M M20 X 1.5	C3	V3 VERSION 3
P	POWER SAVER SOLENOID	E 110V AC	P 28MM	04 04.00	T ¾" NPT
B	IP67 WEATHER PROOF JUNCTION BOX	F 12V DC	Q 30MM	05 05.00	B BARE LUG	C9	V9 VERSION 9
S	SQUARE	G 24V DC	E 05MM	06 06.00	G Automotive Connector Male	CA	VA VERSION 10
		I 400V FAC	D 12MM	07 07.00	A Automotive Connector Female	CB	VB VERSION 11
		J 230V FAC	J 16MM	08 08.00			
		M 24V FAC		09 09.00			
		N 415V AC		10 10.00			
		O 36V DC		11 11.00			
		P 110V FAC		12 12.00			
		Q 110V DC		...			
		R 48V DC		33 33.00			
		S 120V AC					
		T 28V DC					
		U 6V DC					
		V 280V AC					
		W 9V DC					
		X 256V DC					
		Y 330V FAC					
		Z 220V DC					
		1 415V FAC					
		2 400V AC					
		3 480V AC					
		4 5V DC					
		5 5V AC					
		6 380V AC					
		7 200V AC					

RAI08L
ROUND SOLENOID 230V AC 14MM Ø8W LEAD WIRE

Note: The above chart is for identification purposes only, and it may not be possible to make all combinations for the above chart.

LATCHING SOLENOID COIL MODEL IDENTIFICATION CHART

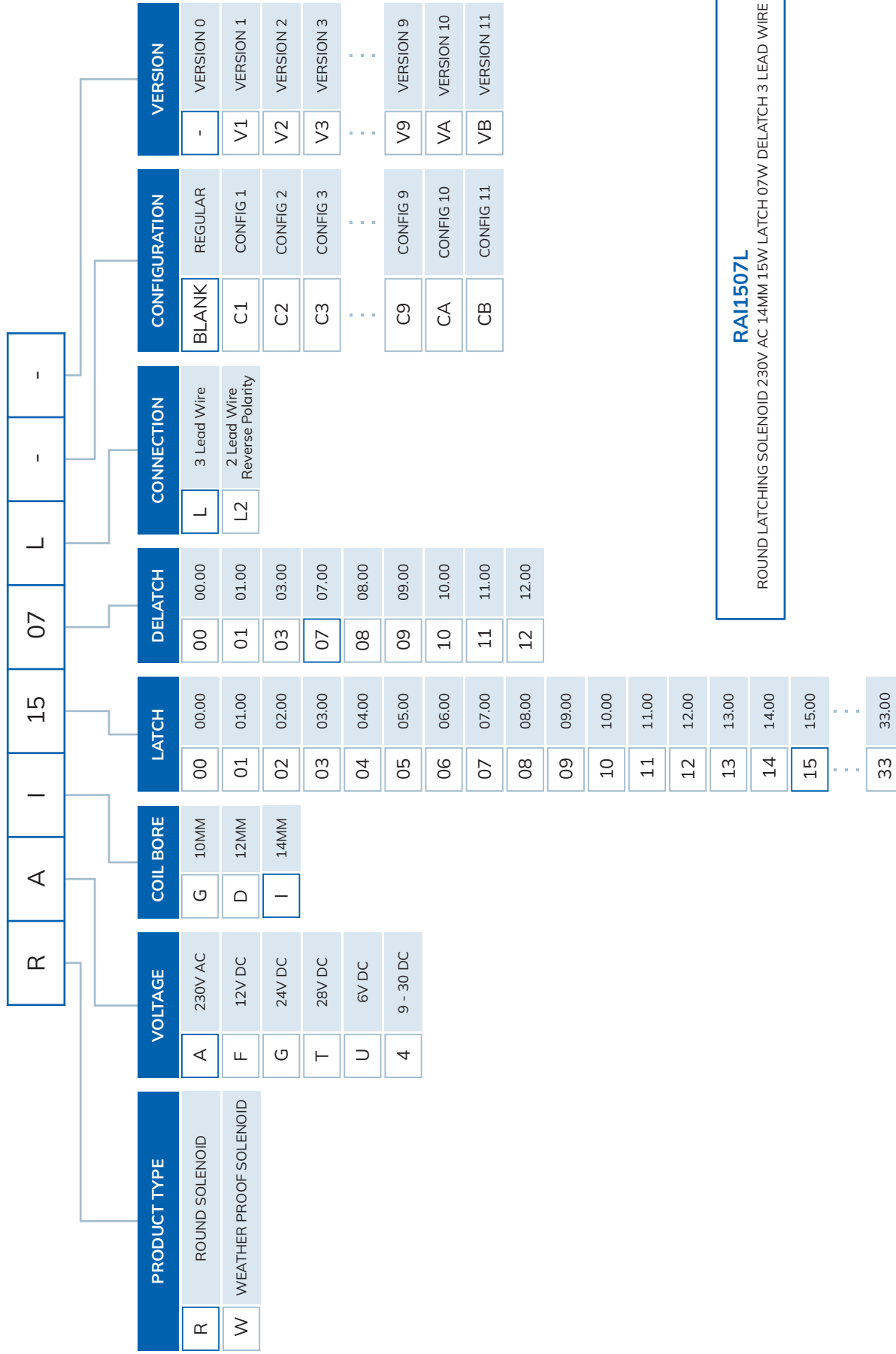

EXPLOSION PROOF SOLENOID ACTUATOR MODEL IDENTIFICATION CHART

		X1	X2	X3	X4	X5	X6	X7	X8			
		COIL BORE		WATTAGE		CONNECTION		BODY MATERIAL		CONFIGURATION		VERSION
TYPE	VOLTAGE	A	I	00	D	A	BLANK	V0	VERSION 0			
T37	TR CU Solenoid Explosion Proof Horizontal Cable Entry	230V AC	14MM	00.00	1/2" National Pipe Taper Thread	Aluminum	NORMAL	V0	VERSION 0			
T47	TR CU Solenoid Explosion Proof Bottom Cable Entry	24V AC	18 MM	01	3/4" National Pipe Taper Thread	CF8	C1	V1	VERSION 1			
		42V AC		02	M20 x 1.5 Metric Thread	CF8M	C2	V2	VERSION 2			
		48V AC		03	3/4" Electrical Thread	CF3M	C3	V3	VERSION 3			
		110V AC		04	M25x1.5 Metric Thread				
		12V DC		05			C9	V9	VERSION 9			
		24V DC		06			CA	VA	VERSION 10			
		400V FAC		07			CB	VB	VERSION 11			
		230V FAC		08								
		24V FAC		09								
		415V AC		10								
		36V DC		11								
		110V FAC		12								
		110V DC		...								
		48V DC		22								
		120V AC										
		28V DC										
		6V DC										
		280V AC										
		9V DC										
		256V DC										
		330V FAC										
		220V DC										
		415V FAC										
		400V AC										
		480V AC										
		5V DC										
		5V AC										
		380V AC										
		200V AC										

Structure of the coil symbol:

- X1: Type Solenoid Explosion Proof Horizontal Cable Entry, Solenoid Explosion Proof Bottom Cable Entry - Type 37 & Type 47
- X2: Voltage (5V to 480V) A to 7
- X3: Coil Bore or Dia 14mm & 18mm (I TO K)
- X4: Power (0 watt to 22 watt)
- X5: Connection Type (Electric connection type D TO H)
- X6: Body Material (A TO L)
- X7: Configuration (C1 TO CB)
- X8: Version (V0-VB)

Type 37 - Temperature Class of Horizontal Cable Gland - T6... T3
Type 47 - Lower Cable Gland Temperature Class - T6... T3



ATEX EXPLOSION PROOF SOLENOID ACTUATOR MODEL IDENTIFICATION CHART

		X1	X2	X3	X4	X5	X6	X7	X8				
		COIL BORE		WATTAGE		CONNECTION		BODY MATERIAL		CONFIGURATION		VERSION	
TYPE	VOLTAGE	COIL BORE		WATTAGE		CONNECTION		BODY MATERIAL		CONFIGURATION		VERSION	
E37	A 230V AC	I 14MM	00	D	1/2" National Pipe Taper Thread	A	Aluminum	BLANK	V0	VERSION 0			
E47	B 24V AC	K 18MM	01	E	3/4" National Pipe Taper Thread	C	CF8	C1	V1	VERSION 1			
	C 42V AC		02	F	M20 x 1.5 Metric Thread	M	CF8M	C2	V2	VERSION 2			
	D 48V AC		03	G	3/4" Electrical Thread	L	CF3M	C3	V3	VERSION 3			
	E 110V AC		04	H	M25x1.5 Metric Thread								
	F 12V DC		05										
	G 24V DC		06										
	I 400V FAC		07					C9	V9	VERSION 9			
	J 230V FAC		08					CA	VA	VERSION 10			
	M 24V FAC		09					CB	VB	VERSION 11			
	N 415V AC		10										
	O 36V DC		11										
	P 110V FAC		12										
	Q 110V DC												
	R 48V DC												
	S 120V AC												
	T 28V DC												
	U 6V DC												
	V 280V AC												
	W 9V DC												
	X 256V DC												
	Y 330V FAC												
	Z 220V DC												
	1 415V FAC												
	2 400V AC												
	3 480V AC												
	4 5V DC												
	5 5V AC												
	6 380V AC												
	7 200V AC												

Structure of the coil symbol:

- X1: Type Solenoid Explosion Proof Horizontal Cable Entry, Solenoid Explosion Proof Bottom Cable Entry - Type 37 & Type 47
- X2: Voltage (5V to 480V) A to 7
- X3: Coil Bore or Dia 14mm & 18mm (I TO K)
- X4: Power (0 watt to 22 watt)
- X5: Connection Type (Electric connection type D TO H)
- X6: Body Material (A TO L)
- X7: Configuration (C1 TO CB)
- X8: Version (V0-VB)

Type 37 - Temperature Class of Horizontal Cable Gland - T6... T3
Type 47 - Lower Cable Gland Temperature Class - T6... T3





ANGLE SEAT VALVE SERIES



Angle seat valves are 2/2 way pneumatically actuated piston valves. The piston actuator provides a linear motion to lift the seal off its seat. Because the seat is positioned under an angle, the flow is minimally impeded in the open position, resulting in an excellent flow rate and a low pressure loss. They are used to regulate the flow of liquids, gases, steam, vacuum and even aggressive fluids. They can also operate with high temperatures and high viscosity media, even under zero differential pressures. The robust design makes UFLOW angle seat valves a popular choice for harsh applications and they have very high life cycle. Therefore they are an excellent alternative to Ball valves with actuator combo. These valves are also suitable alternatives for solenoid valves, especially with contaminated, viscous media where typical solenoid valves would fail. They may be operated using a single acting or double acting configuration, which has an influence on its pressure rating.

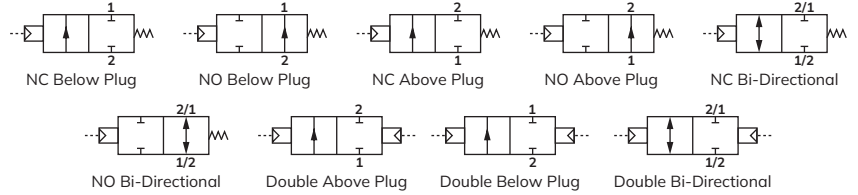

Specifications

Port :	1/2", 3/4", 1", 1 1/4", 1 1/2", 2" & 2 1/2" (Available in BSP / NPT)
End Connection :	Screwed / Flange / Tri-Clamp / Socket Weld
Body & Sleeve Material :	SS ASTM A351 Grade CF8 / CF8M / CF3M
Seal :	PTFE / PEEK / VITON
Shaft :	SS304 / SS316
Circumstance Temp :	-10°C to 70°C
Media Temp :	-10°C to 180°C
Other Specification Data:	Available on request - Adjust Stroke Limiter - Position Sensor

Features

- Convertible from single Acting to Double Acting.
- Multiple Function with the same operator - NC / NO / Bi-Directional.
- Rotatable Actuator- 360°.
- Transparent dome for visual confirmation of the valve's position/state
- Lubricated air not essential.
- Flow direction below or above the seat.
- Media: Steam, Air, Water, Chemical, Gases, Oil, Diesel, Hot Water.
- Application: Steam, Autoclave and Sterilizer, Ink and Paint dispensing, Industrial compressor bottling and dispensing equipment, textile dying and drying and pharmaceutical.

Section View



Actuator Type

Cover :	Nylon Glass-Filled (Corrosion resistive) with SS Liner
Seal :	NBR / VITON
Working Pressure :	Refer Below Pressure Chart Table
Life :	Three Million Cycle Tested
Other Technical Data :	Available on Request

Dimension With Screwed End (All dimensions in mm)

All Dimensions are approx.

Model No.	Actuator	Port Size	Diagram No.	A	B	C	D	E	F	G	H	I
ACP-2054V1	40	1/2"	28.1	65	144	131	154	65	24	G 3/4"	32	M5
ACP-2055V1	50	1/2"	28.1	65	153	141	163	70	24	G 3/4"	32	M5
ACP-2056V1	63	1/2"	28.1	65	171	158	181	85	24	G 3/4"	32	M5
ACP-3054V1	40	3/4"	28.1	77	150	134	161	65	24	G 1/2"	32	M5
ACP-3055V1	50	3/4"	28.1	77	160	144	171	70	24	G 1/2"	32	M5
ACP-3056V1	63	3/4"	28.1	77	177	161	187	85	24	G 1/2"	32	M5
ACP-4055V2	50	1"	28.1	89	177	157	185	70	24	G 1/2"	32	M5
ACP-4056V2	63	1"	28.1	89	194	174	202	85	24	G 1/2"	32	M5
ACP-4059V2	90	1"	28.1	89	221	201	229	126	24	G 1/2"	32	M5
ACP-5056V2	63	1 1/4"	28.1	110	199	175	209	85	24	G 3/4"	32	M5
ACP-5059V2	90	1 1/4"	28.1	110	225	201	236	126	24	G 3/4"	32	M5
ACP-6059V2	90	1 1/2"	28.1	124	239	211	247	126	24	G 3/4"	32	M5
ACP-8059V2	90	2"	28.1	150	260	227	269	126	24	G 3/4"	32	M5
ACP-9039V2	90	2 1/2"	28.1	168	281	239	261	126	24	G 3/4"	32	M5

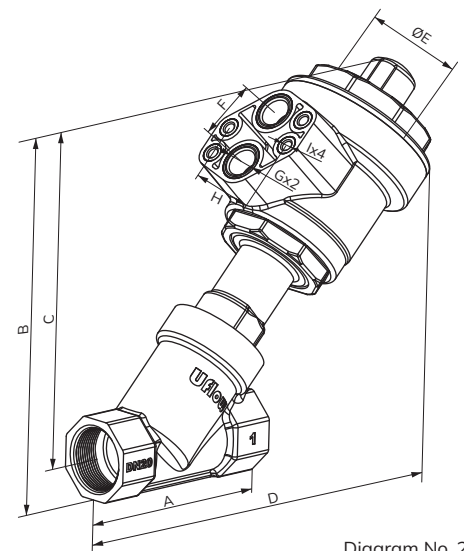
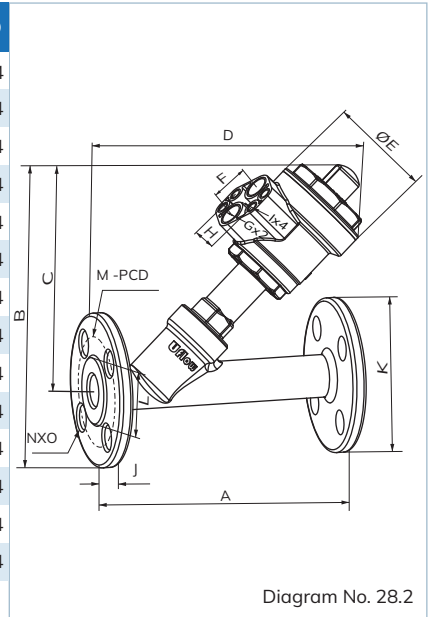

Diagram No. 28.1

Dimension With Flange (ASME 16.5 #150) (All dimensions in mm)

All Dimensions are approx.

Model No.	Actuator	Port Size	Diagram No.	A	B	C	D	E	F	G	H	I	J	K	L	M	NXO
ACP-2054FV1	40	½"	28.2	163	176	131	165	65	24	G¾"	32	M5	8	90	35	60	16X4
ACP-2055FV1	50	½"	28.2	163	186	141	175	70	24	G¾"	32	M5	8	90	35	60	16X4
ACP-2056FV1	63	½"	28.2	163	203	158	192	85	24	G¾"	32	M5	8	90	35	60	16X4
ACP-3054FV1	40	¾"	28.2	172	184	134	171	65	24	G¾"	32	M5	9	100	43	70	16X4
ACP-3055FV1	50	¾"	28.2	172	194	144	181	70	24	G¾"	32	M5	9	100	43	70	16X4
ACP-3056FV1	63	¾"	28.2	172	211	161	198	85	24	G¾"	32	M5	9	100	43	70	16X4
ACP-4055FV2	50	1"	28.2	181	212	157	196	70	24	G¾"	32	M5	10	110	51	79	16X4
ACP-4056FV2	63	1"	28.2	181	229	174	208	85	24	G¾"	32	M5	10	110	51	79	16X4
ACP-4059FV2	90	1"	28.2	181	256	201	240	126	24	G¾"	32	M5	10	110	51	79	16X4
ACP-5056FV2	63	1¼"	28.2	182	233	175	227	85	24	G¾"	32	M5	11	115	64	89	17X4
ACP-5059FV2	90	1¼"	28.2	182	259	202	254	126	24	G¾"	32	M5	11	115	64	89	17X4
ACP-6059FV2	90	1½"	28.2	212	274	211	269	126	24	G¾"	32	M5	13	125	73	98	16X4
ACP-8059FV2	90	2"	28.2	208	302	226	275	126	24	G¾"	32	M5	14	150	91	121	19X4
ACP-9039FV2	90	2½"	28.2	231	329	239	294	126	24	G¾"	32	M5	13	180	106	140	20X4



Dimension With Tri-Clamp (All dimensions in mm)

All Dimensions are approx.

Model No.	Actuator	Port Size	Diagram No.	A	B	C	D	E	F	G	H	I	J
ACP-2054TV1	40	½"	28.3	109	148	131	176	65	24	G¾"	32	M5	34
ACP-2055TV1	50	½"	28.3	109	158	141	185	70	24	G¾"	32	M5	34
ACP-2056TV1	63	½"	28.3	109	175	158	203	85	24	G¾"	32	M5	34
ACP-3054TV1	40	¾"	28.3	115	160	134	180	65	24	G¾"	32	M5	50
ACP-3055TV1	50	¾"	28.3	115	169	144	190	70	24	G¾"	32	M5	50
ACP-3056TV1	63	¾"	28.3	115	186	161	207	85	24	G¾"	32	M5	50
ACP-4055TV2	50	1"	28.3	130	182	157	206	70	24	G¾"	32	M5	50
ACP-4056TV2	63	1"	28.3	130	199	173	222	85	24	G¾"	32	M5	50
ACP-4059TV2	90	1"	28.3	130	225	200	249	126	24	G¾"	32	M5	50
ACP-5056TV2	63	1¼"	28.3	145	200	175	227	85	24	G¾"	32	M5	50
ACP-5059TV2	90	1¼"	28.3	145	227	202	254	126	24	G¾"	32	M5	50
ACP-6059TV2	90	1½"	28.3	160	243	211	264	126	24	G¾"	32	M5	64
ACP-8059TV2	90	2"	28.3	190	258	226	288	126	24	G¾"	32	M5	64

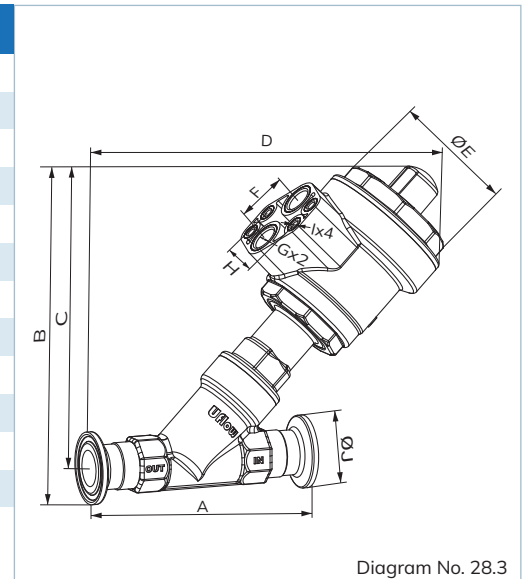

Technical Data

Pipe (Inch)	Body Material	Orifice (mm)	Seal & 'O' Ring Material	Flow Factor Kv m³ / hr
½"	CF8 / CF8M	15	PTFE / PEEK / VITON	6
¾"	CF8 / CF8M	20	PTFE / PEEK / VITON	10.9
1"	CF8 / CF8M	25	PTFE / PEEK / VITON	21
1¼"	CF8 / CF8M	32	PTFE / PEEK / VITON	35
1½"	CF8 / CF8M	40	PTFE / PEEK / VITON	49
2"	CF8 / CF8M	50	PTFE / PEEK / VITON	68
2½"	CF8 / CF8M	65	PTFE / PEEK / VITON	120

Pressure Chart

Pipe (Inch)	Actuator	NC				NO				Double Acting			
		Above Plug		Below Plug		Above Plug		Below Plug		Above Plug		Below Plug	
		Pilot Pressure	Line Pressure	Pilot Pressure	Line Pressure	Pilot Pressure	Line Pressure	Pilot Pressure	Line Pressure	Pilot Pressure	Line Pressure	Pilot Pressure	Line Pressure
½"	40	4.5	16	-	-	4.5	16	-	-	4.5	20	4	16
		4.5	20	-	-	6	18	-	-	3	16	4.5	20
¾"	40	5.5	16	-	-	-	-	-	-	3.8	16	4.5	16
		6.2	19	-	-	-	-	-	-	5	20	5	20
		-	-	-	-	-	-	-	-	-	-	-	-
¾"	50	4.5	16	-	-	4	13	6.5	12	3.5	16	5	16
		5.5	20	-	-	-	-	-	-	4.5	20	5.5	20
		-	-	-	-	-	-	-	-	-	-	-	-
1"	63	5.5	16	-	-	4.5	15	7	8	4.5	16	4.5	16
		4.5	20	-	-	-	-	-	-	4.5	20	5	20
		-	-	-	-	-	-	-	-	-	-	-	-
1¼"	63	6.5	16	-	-	4.5	13	-	-	3.5	16	6	16
		6.5	20	-	-	-	-	-	-	6	20	6.5	20
1½"	63	4.5	12	-	-	-	-	7	9	5	10	-	-
		-	-	-	-	4.5	8	-	-	7	16	-	-
		-	-	-	-	-	-	-	-	-	-	-	-
1½"	90	4.5	16	-	-	4.5	10	7	9	4.7	16	4	16
		5	20	-	-	-	-	-	-	5	20	5	20
		-	-	-	-	-	-	-	-	-	-	-	-
2"	90	5.8	16	-	-	5	16	7	10	5.5	16	7	18
		7	19	-	-	-	-	-	-	6.2	20	-	-
		-	-	-	-	-	-	-	-	-	-	-	-
2½"	90	7	10.5	-	-	-	-	-	-	-	-	-	-
		4.5	7	-	-	-	-	-	-	-	-	-	-

Pressure Above Plug

Pressure Below Plug

	A	B
Normally Open	Pilot Inlet	Exhaust
Normally Close	Exhaust	Pilot Inlet

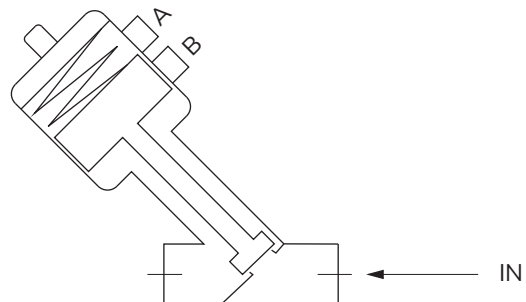
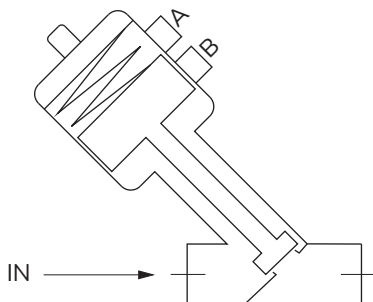

ACP - SERIES ANGLE SEAT VALVE WITH PLASTIC OPERATOR MODEL CHART

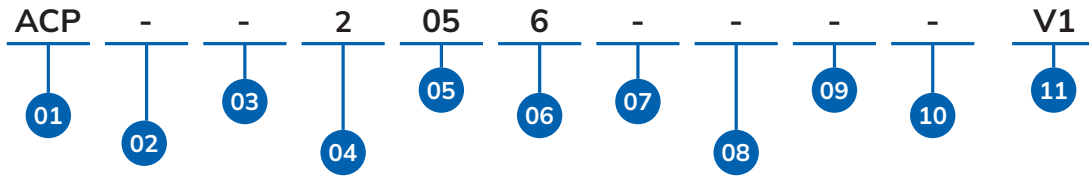

01	SERIES
ACP	

02	PRODUCT TYPE
-	Angle Seat Valve Plastic Operator

03	BODY MATERIAL
-	CF8
M	CF8M
C	CF3M

04	PORT SIZE
2	1/2"
3	3/4"
4	1"
5	1-1/4"
6	1-1/2"
8	2"
9	2 1/2"

05	PRESSURE RANGE
02	0 - 2 Bar
03	0 - 7 Bar
04	0 - 10 Bar
05	0 - 16 Bar
11	0 - 25 Bar
13	0 TO 4 Bar
14	0 - 3 Bar
21	0 TO 20 Bar
32	0 TO 8 Bar
38	0 TO 12 Bar

06	ACTUATOR SIZE
4	40 Namur
5	50 Namur
6	63 Namur
8	80 Namur
9	90 Namur
1	100 Namur

07	PORT CONNECTION
-	BSP
N	NPT
F	Flange End
T	Triclover END
P	BSPT
S	SOCKET
G	BSP With SW

08	VALVE POSITION
-	NC Above
Z	NO Above
D	Double Above
C	NC Below
O	NO Below
B	Double Below
R	Bi Directional NC
L	Bi Directional NO
I	Bi Directional DOUBLE

09	APPROVALS
-	No Approval
E	PED

10	CONFIG
-	REGULAR
C1	CONFIG 1
C2	CONFIG 2
C3	CONFIG 3
...	...
C9	CONFIG 9
CA	CONFIG 10
CB	CONFIG 11

11	VERSION
-	VERSION 0
V1	VERSION 1
V2	VERSION 2
V3	VERSION 3
...	...
V9	VERSION 9
VA	VERSION 10
VB	VERSION 11

ACP-2056V1
1/2" ANGLE SEAT VALVE PLASTIC OPERATOR CF8-PTFE-0 TO 16 BAR-63MM NAMUR-BSP-NC ABOVE-VERSION 1

Note: The above chart is for identification purposes only, and it may not be possible to make all combinations for the above chart.

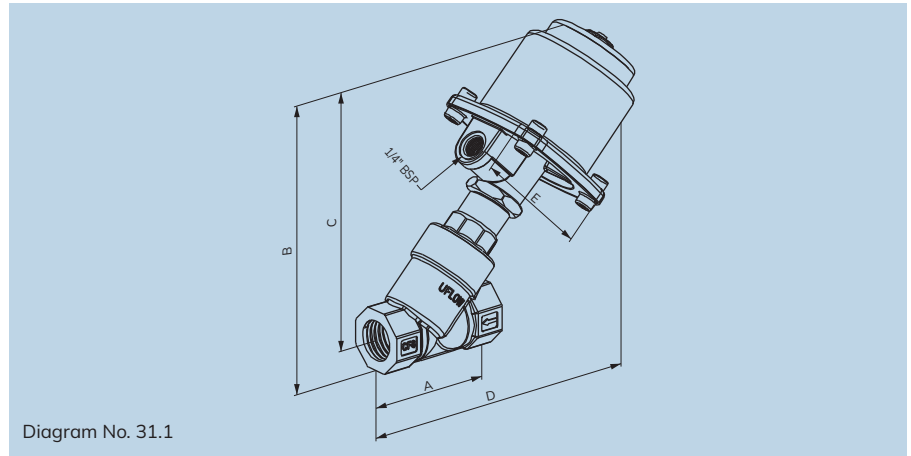
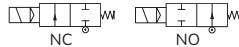

Diagram No. 31.1



Specifications

Port :	½", ¾", 1", 1¼", 1½" & 2" (Available in BSP/NPT)
End Connection :	Screwed / Flange / Tri-Clamp / Socket Weld
Body Material :	SS ASTM A351 Grade CF8 / CF8M / CF3M
Seal :	PTFE / VITON
Circumstance Temp :	-10°C to 70°C
Media Temp :	-10°C to 180°C
Media :	Steam, Air, Water, Chemical, Gases, Oil, Diesel, Hot Water
Other Specification Data:	Available on request - Adjust Stroke Limiter - Position Sensor

Dimension - NC (All dimensions in mm)

All Dimensions are approx.

Model No.	Port Size	Diagram No.	A	B	C	D	E
YCP-205NV1	½"	31.1	65	155	142	165	90
YCP-305NV1	¾"	31.1	77	161	145	171	90
YCP-405NV1	1"	31.1	89	182	162	190	90
YCP-505NV1	1¼"	31.1	110	198	174	209	90
YCP-605NV1	1½"	31.1	124	202	175	210	90
YCP-803NV1	2"	31.1	150	225	191	234	90

Section View

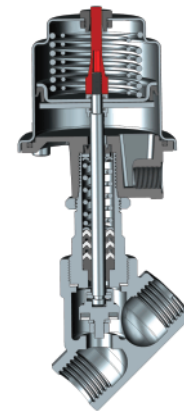

Actuator Type

Cover :	SS304
Plate :	Aluminium Die-Cast
Working Pressure :	3.5 to 7 bar air (Not Recommended actuator for pneumatic pressure above 7 bar)
Seal Material :	NBR / VITON
Life :	More than ten million cycle
Other Technical Data :	Available on Request

Technical Data

Model No.	Body Material	Pipe (Inch)	Orifice (mm)	Min. Operating Pressure Kg/cm ²	Max. Operating Pressure Kg/cm ²	Seal & 'O' Ring Material	Flow Factor Kv m ³ / hr
YCP-205NV1	CF8 / CF8M	½"	15	0	16	PTFE / VITON	6
YCP-305NV1	CF8 / CF8M	¾"	20	0	16	PTFE / VITON	10.9
YCP-405NV2	CF8 / CF8M	1"	25	0	16	PTFE / VITON	21
YCP-505NV2	CF8 / CF8M	1¼"	32	0	16	PTFE / VITON	35
YCP-605NV2	CF8 / CF8M	1½"	40	0	16	PTFE / VITON	49
YCP-803NV2	CF8 / CF8M	2"	50	0	07	PTFE / VITON	68

YCP - SERIES ANGLE SEAT VALVE WITH STEEL OPERATOR MODEL CHART

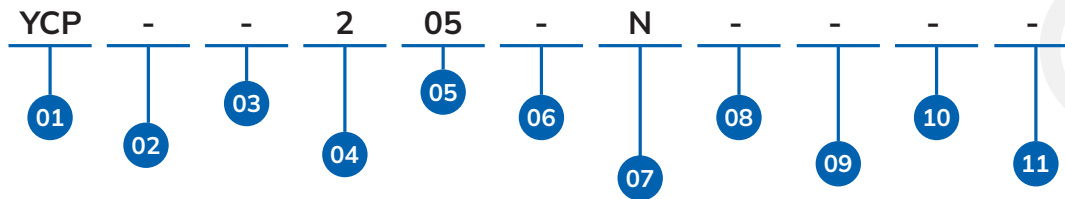

01	SERIES
	YCP

02	PRODUCT TYPE
-	Angle Seat Valve Steel Operator

03	BODY MATERIAL
-	CF8
M	CF8M
C	CF3M

04	PORT SIZE
2	1/2"
3	3/4"
4	1"
5	1-1/4"
6	1-1/2"
8	2"
9	2-1/2"

05	PRESSURE RANGE
11	0 - 25 Bar
14	0 - 3 Bar
17	0 - 60 Bar
21	0 - 20 Bar
02	0 - 2 Bar
03	0 - 7 Bar
04	0 - 10 Bar
05	0 - 16 Bar

06	OPERATOR SIZE
-	70mm
1	100mm
2	120mm

07	PORT CONNECTION
-	BSP
N	NPT
F	Flange End
T	Tri Clover End
G	BSP With SW
P	BSPT
S	Socket

08	VALVE POSITION
-	NC Above
Z	NO Above
C	NC Below
O	NO Below
R	BI Directional NC
L	BI Directional NO

09	APPROVALS
-	No Approval

10	CONFIGURATION
-	REGULAR
C1	CONFIG 1
C2	CONFIG 2
C3	CONFIG 3
⋮	⋮
C9	CONFIG 9
CA	CONFIG 10
CB	CONFIG 11

11	VERSION
-	VERSION 0
V1	VERSION 1
V2	VERSION 2
V3	VERSION 3
⋮	⋮
V9	VERSION 9
VA	VERSION 10
VB	VERSION 11

YCP-205N
1/2" ANGLE SEAT VALVE STEEL OPERATOR CF8-PTFE-0 TO 16 Bar-70MM OPERATOR-NPT-NC ABOVE

Note: The above chart is for identification purposes only, and it may not be possible to make all combinations for the above chart.



Specifications

Port :	Refer below technical data sheet (Available BSP / NPT)
End Connection :	Screw End
Body Material :	SS ASTM A351 Grade CF8
Seal :	PTFE / VITON
Circumstance Temp :	-10°C to 70°C
Media Temp :	-10°C to 180°C
Media :	Steam, Air, Water, Chemical, Gases, Oil, Diesel, Hot Water
Leakage :	As per ANSI B16.104 - 1976 Teflon seating class IV. For other soft seating class VI Drop Tight/Bubble Tight.
Stem Packing :	Self adjusting, Spring loaded Teflon packing.
Air Quality :	Lubricated /Non-lubricated.

Actuator (Spring Return) Type

Cover :	CF8
Plate :	CF8
Working Pressure :	4.5 to 7 bar air (Not Recommended actuator for pneumatic pressure above 7 bar)
Seal Material :	NBR / VITON
Life :	1 million cycle
Other Technical Data :	Available on Request

Mixing

Valves can be used for introducing two different fluids (mixing) through two different ports to common port 'AB'.

Diverting

One fluid coming through port 'AB' can be diverted to 'A' port or 'B' port.

Technical Data

Model No.	Body Material	Pipe (Inch)	Orifice (mm)	Min. Operating Pressure Kg/cm ²	Max. Operating Pressure Kg/cm ²	Seal & 'O' Ring Material	Flow Factor Kv m ³ / hr
TCP-8Z	CF8	2"	45	0	7	PTFE	35

Operation

In normal condition, 'A' port is closed and 'AB' port is connected to 'B' or 'B' port is connected to 'AB' port. On receiving pilot pressure, 'A' port is connected to 'AB' or 'AB' port is connected to 'A' closing port B.

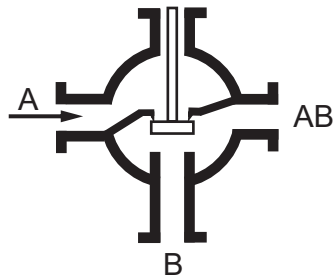
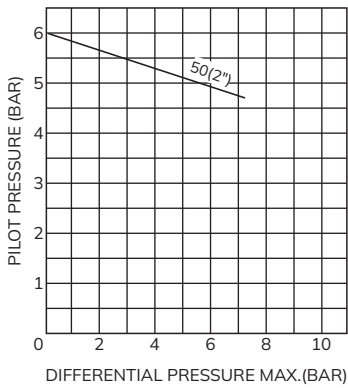

Pressure at Port 'A',
AB Connected 'B' 'A' is Close.

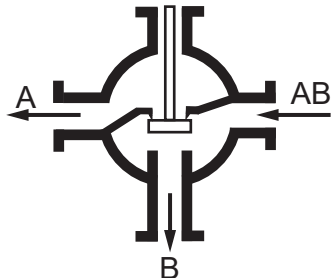

Diverting - Pressure at 'AB'
Connected to 'B' 'A' Port is Close.

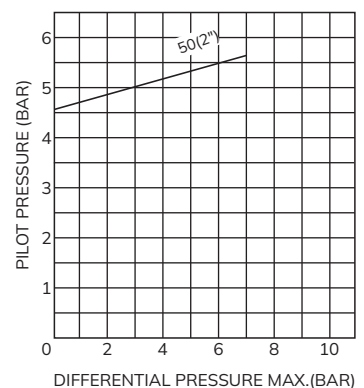

Dimension (All dimensions in mm)

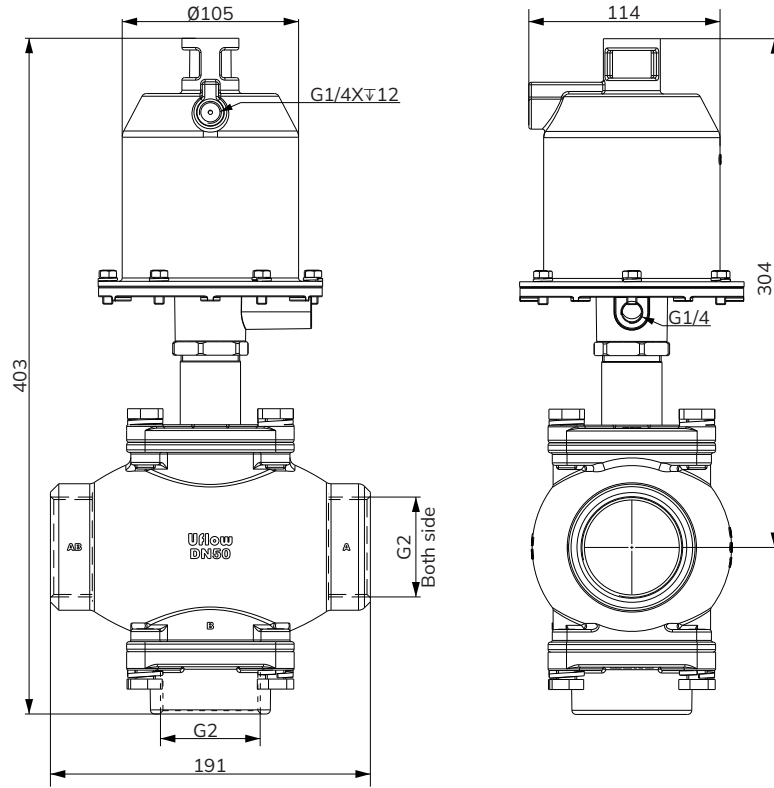

* All dimensions are approx

3 WAY CONTROL VALVE WITH STEEL OPERATOR MODEL CHART

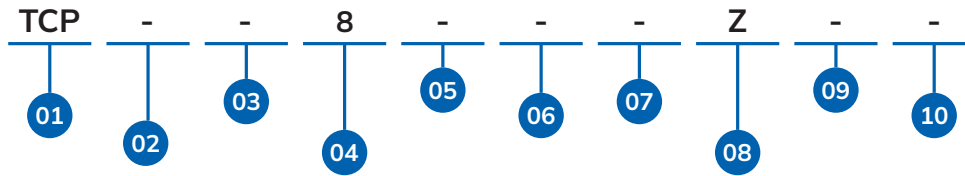

01	SERIES
TCP	

02	PRODUCT TYPE
-	3 Way Control Valve SS Operator

03	BODY MATERIAL
-	CF8
M	CF8M
3	CF3M

04	PORT SIZE
8	2"

05	PRESSURE RANGE
-	0 - 7 Bar

06	ACTUATOR SIZE
-	100 Clean

07	PORT CONNECTION
-	BSP
N	NPT
F	Flange End

08	VALVE POSITION
-	NC Above
Z	NO Above
R	BI Directional NC
L	BI Directional NO

09	CONFIGURATION
-	REGULAR
C1	CONFIG 1
C2	CONFIG 2
C3	CONFIG 3
⋮	⋮
C9	CONFIG 9
CA	CONFIG 10
CB	CONFIG 11

10	VERSION
-	VERSION 0
V1	VERSION 1
V2	VERSION 2
V3	VERSION 3
⋮	⋮
V9	VERSION 9
VA	VERSION 10
VB	VERSION 11

TCP-8Z
2" 3 WAY CONTROL VALVE CF8-PTFE-0 TO 7 Bar
-100 CLEAN-BSP-NO ABOVE



PNEUMATIC ACTUATOR SERIES

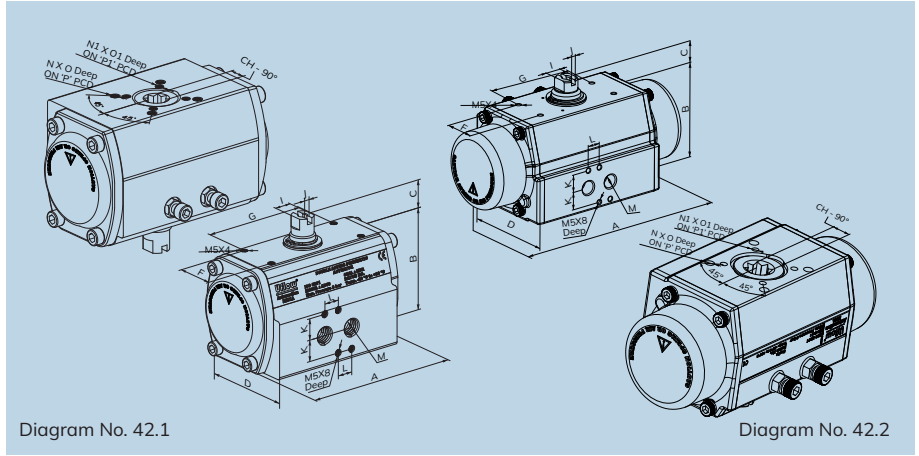

Features

Uflow has successfully developed Compact, Patented Aluminium Free Rack & Pinion Pneumatic Rotary Actuator and Consuming Low Volume of Air.

- ✓ Wear proof aluminium free Rack & Pinion design.
- ✓ Low air consumption with maximum torque due to compact design.
- ✓ Providing a hard-anodized body for high corrosion resistance.
- ✓ Smooth travelling stroke for extending the life of ball valve seat.
- ✓ Finer teeth module for smoother operation, and jerk-free sliding.
- ✓ Maintenance free design.
- ✓ Aluminium Extruded, Hard Anodized Body.
- ✓ Design Standard : ISO 5211.
- ✓ Approved as per ATEX.

Section View



Temperature Range

NBR	-20°C to +80°C
Viton	-20°C to +125°C
Flourosilicone	-60°C to +110°C

End Stroke (0° - 90°)

+5° Over travelling possible for opening
-5° Under travelling can be adjusted

Working Pressure

Maximum working pressure 8 bar

Air Consumption Comparison With Other Reputed Brand

Model	Piston Inward Stroke ml / bar	Piston Outward Stroke ml / bar
(Uflow)AD50	128	137
Other Brand Y	260	110
Other Brand X	200	180

Technical Data (All dimensions in mm)

All Dimensions are approx.

Model No. Double / Single	Diagram No.	A Double / Single	B	C	D	F	G	I	J	K	L	M	N	O	P	N1	O1	P1	CH 90°	ISO FLANGE
AD-32V2 / AS-3221V2	42.1 / 42.2	92 / 115	48	20	54	30	50	10	4	16	12	1/8"	M5	09	36	-	-	-	09	F03
AD-40V2 / AS-4012V2	42.1 / 42.2	129/161	66	20	64	30	80	13	4	16	12	1/4"	M6	12	50	M5	10	36	11	F03/F05
AD-50V2 / AS-5012V2	42.1 / 42.2	125/163	77	20	72	30	80	13	4	16	12	1/4"	M6	12	50	M5	10	36	11	F03/F05
AD-63V2 / AS-6312V2	42.1 / 42.2	147/203	87	20	86	30	80	15	4	16	12	1/4"	M8	12	70	M6	10	50	14	F05/F07
AD-80V2 / AS-80201V2	42.1 / 42.2	170/235	103	20	98	30	80	18	4	16	12	1/4"	M8	12	70	M6	10	50	17	F05/F07
AD-90V2 / AS-90201V2	42.1 / 42.2	198/277	115	20	110	30	80	22	4	16	12	1/4"	M8	12	70	-	-	-	17	F07
AD-100V2 / AS-10012V2	42.1 / 42.2	220/324	129	20	127	30	80	26	4	16	12	1/4"	M10	15	102	M8	14	70	22	F07/F10
AD-110V2 / AS-11012V2	42.1 / 42.2	231/332	136	20	131	30	80	30	4	16	12	1/4"	M10	15	102	M8	14	70	22	F07/F10
AD-125V2 / AS-12511V2	42.1 / 42.2	389	161	20	146	30	80	30	4	16	12	1/4"	M12	20	125	M10	14	102	22	F10/F12
AD-150V2 / AS-15011V2	42.1 / 42.2	465	193	20	176	30	80	36	4	16	12	1/4"	M12	20	125	M10	14	102	27	F10/F12
AD-175V2 / AS-17513UV2	42.1 / 42.2	500	212	20.5	195	30	80	41	4	16	12	1/4"	M12	20	125	M10	20	102	27	F10/F12
AD-200V2 / AS-200A6UV2	42.1 / 42.2	552	255	30	288	30	130	41	4	16	12	1/4"	M16	24	140	M10	15	102	36	F10/F14
AD-250V2 / AS2506UV2	42.1 / 42.2	723	255	30	288	30	130	41	4	16	12	1/4"	M16	24	140	-	-	-	46	F14
AD-300V2 / AS-3006UV2	42.1 / 42.2	755	360	30	390	30	130	41	4	22.5	20	1/2"	M20	30	165	-	-	-	46	F16
AD-350V2 / AS-3506UV2	42.1 / 42.2	865	360	30	390	30	130	41	4	22.5	20	1/2"	M20	30	165	-	-	-	55	F16

Torque Chart (Double Acting)

TORQUE Nm (10Nm = 1 Kgm)

Model No.	Diagram No.	2 Bar	3 Bar	4 Bar	5 Bar	6 Bar	7 Bar	8 Bar	Piston Inward Stroke, ml/bar	Piston Outward Stroke, ml/bar
AD-32V2	42.1	3	5	6	8	9	11	12	36	40
AD-40V2	42.1	7	10	14	17	21	24	28	83	104
AD-50V2	42.1	11	16	22	27	32.5	38	43	128	137
AD-63V2	42.1	20	30	40	50	60	70	80	210	280
AD-80V2	42.1	35	52	69	87	103	121	138	360	450
AD-90V2	42.1	51	76	102	127	153	178	204	522	768
AD-100V2	42.1	73	110	146	183	220	256	293	780	1040
AD-110V2	42.1	90	135	180	225	270	315	360	966	1325
AD-125V2	42.1	127	190	254	318	381	446	508	2800	1810
AD-150V2	42.1	210	316	421	526	631	737	842	5390	3150
AD-175V2	42.1	300	450	600	750	900	1050	1200	7525	4720
AD-200V2	42.1	456	684	912	1140	1368	1596	1824	11980	7780
AD-250V2	42.1	741	1111	1482	1852	2223	2593	2964	14870	12145
AD-300V2	42.1	1125	1688	2251	2813	3376	3939	4502	37175	19630
AD-350V2	42.1	1540	2310	3080	3850	4620	5390	6160	40535	26430

Torque Chart (Single Acting)

TORQUE Nm (10Nm = 1 Kgm)

Size	Model No.	Spring Set	Spring Torque		3 Bar		4 Bar		5 Bar		6 Bar		Piston Outward Stroke, ml/bar
			0° (Min)	90° (Max)	90° (Min)	0° (Max)	90° (Min)	0° (Max)	90° (Min)	0° (Max)	90° (Min)	0° (Max)	
32	AS-3221V2	21	2	3	2	3	3	4	5	6	6	7	40
	AS-3212V2	12	3	5	-	-	1	3	3	5	4	6	
	AS-3222V2	22	4	6	-	-	1	2	2	4	3	5	
40	AS-4002V2	02	5	8	3	5	6	9	10	12	13	16	104
	AS-4021V2	21	5	8	2	5	6	8	9	12	12	15	
	AS-4012V2	12	6	10	1	4	4	7	7	11	11	14	
	AS-4022V2	22	8	12	-	-	2	6	5	9	9	13	
50	AS-5002V2	02	6	13	3	10	9	16	14	21	20	27	137
	AS-5021V2	21	8	14	2	8	8	14	13	19	19	25	
	AS-5012V2	12	9	16	-	-	6	13	11	18	17	24	
	AS-5022V2	22	12	18	-	-	4	10	9	15	15	21	
63	AS-6302V2	02	11	22	8	19	18	29	28	39	38	49	280
	AS-6321V2	21	15	24	6	15	16	25	26	35	36	45	
	AS-6312V2	12	16	29	1	14	11	24	21	34	31	44	
	AS-6322V2	22	21	35	-	-	5	19	15	29	25	39	
80	AS-80201V2	201	13	23	29	39	46	56	63	73	80	90	450
	AS-80211V2	211	19	34	18	33	35	50	52	67	69	84	
	AS-80121V2	121	23	40	12	29	29	46	46	63	63	80	
	AS-80112V2	112	23	43	9	29	26	46	43	63	60	80	
	AS-80212V2	212	26	47	5	26	22	43	39	60	56	77	
	AS-80222V2	222	36	61	-	-	8	33	25	50	42	67	

Torque Chart (Single Acting)

TORQUE Nm (10Nm = 1 KgM)

Size	Model No.	Spring Set	Spring Torque		3 Bar		4 Bar		5 Bar		6 Bar		Piston Outward Stroke, ml/bar
			0° (Min)	90° (Max)	90° (Min)	0° (Max)	90° (Min)	0° (Max)	90° (Min)	0° (Max)	90° (Min)	0° (Max)	
90	AS-90201V2	201	27	41	35	49	61	75	86	100	112	126	768
	AS-90211V2	211	34	54	22	42	48	68	73	93	99	119	
	AS-90121V2	121	36	58	18	40	44	66	69	91	95	117	
	AS-90112V2	112	43	68	8	33	34	59	59	84	85	110	
	AS-90212V2	212	49	77	-	27	25	53	50	78	76	104	
	AS-90222V2	222	57	90	-	19	12	45	37	70	63	96	
100	AS-1006UV2	6U	40	59	51	70	87	106	124	143	161	180	1040
	AS-1007U2V2	7U2	51	77	33	59	69	95	106	132	143	169	
	AS-10009V2	9	53	81	29	57	65	93	102	130	139	167	
	AS-10010UV2	10U	61	96	14	49	50	85	87	122	124	159	
	AS-10012V2	12	71	109	-	-	37	75	74	112	111	149	
	AS-10014V2	14	83	127	-	-	19	63	56	100	93	137	
110	AS-1106UV2	6U	48	75	60	87	105	132	150	177	195	222	1325
	AS-1107U2V2	7U2	60	94	41	75	86	120	131	165	176	210	
	AS-11009V2	9	66	101	34	69	79	114	124	159	169	204	
	AS-11010UV2	10U	78	120	15	57	60	102	105	147	150	192	
	AS-11012V2	12	88	135	-	47	45	92	90	137	135	182	
	AS-11014V2	14	102	157	-	33	23	78	68	123	113	168	
125	AS-1256UV2	6U	62	99	91	128	155	192	219	256	282	319	1810
	AS-1258UV2	8U	81	129	61	109	125	173	188	236	252	300	
	AS-12509V2	9	86	137	53	104	117	168	181	231	244	295	
	AS-12511V2	11	105	167	23	85	87	149	151	212	214	276	
	AS-12512UV2	12U	119	190	-	-	64	135	128	198	191	262	
	AS-12513UV2	13U	129	205	-	-	49	125	113	189	176	252	
150	AS-1506UV2	6U	105	170	146	211	251	316	356	421	461	526	3150
	AS-1508UV2	8U	137	222	94	179	199	284	304	389	409	494	
	AS-15009V2	9	144	234	82	172	187	277	294	382	391	487	
	AS-15011V2	11	176	285	30	140	135	245	240	350	345	455	
	AS-15012UV2	12U	201	326	-	115	95	220	200	325	305	430	
	AS-15013UV2	13U	217	352	-	99	69	204	174	309	279	414	
175	AS-1756UV2	6U	145	238	212	305	362	455	512	605	662	755	4720
	AS-1758UV2	8U	190	311	139	260	289	410	439	560	589	710	
	AS-17509V2	9	201	330	120	249	270	399	420	549	570	699	
	AS-17511V2	11	245	403	47	205	197	355	347	505	497	655	
	AS-17512UV2	12U	279	458	-	171	142	321	292	471	442	621	
	AS-17513UV2	13U	301	494	-	149	106	299	256	449	406	599	

Torque Chart (Single Acting)

TORQUE Nm (10Nm = 1 KgM)

Size	Model No.	Spring Set	Spring Torque		3 Bar		4 Bar		5 Bar		6 Bar		Piston Outward Stroke, ml/bar
			0° (Min)	90° (Max)	90° (Min)	0° (Max)	90° (Min)	0° (Max)	90° (Min)	0° (Max)	90° (Min)	0° (Max)	
200	AS-2007UV2	7U	235	425	259	449	487	677	715	905	943	1133	7780
	AS-20010V2	10	315	567	117	369	345	597	573	825	801	1053	
	AS-20014V2	14	440	794	-	244	118	472	346	700	574	928	
250	AS-2507UV2	7U	382	688	423	729	794	1100	1164	1470	1535	1841	12145
	AS-25010V2	10	509	919	192	602	563	973	933	1343	1304	1714	
	AS-25014V2	14	713	1287	-	398	195	769	565	1139	936	1510	
300	AS-3007UV2	7U	692	1055	633	996	1196	1559	1758	2121	2321	2684	19630
	AS-30010V2	10	925	1407	281	763	844	1326	1406	1888	1969	2451	
	AS-30014V2	14	1295	1970	-	393	281	956	843	1518	1406	2081	
350	AS-3507UV2	7U	947	1443	867	1363	1637	2133	2407	2903	3177	3673	26430
	AS-35010V2	10	1264	1925	385	1046	1155	1816	1925	2586	2695	3356	
	AS-35014V2	14	1769	2695	-	541	385	1311	1155	2081	1925	2851	

AD - SERIES DOUBLE ACTING ROTARY ACTUATOR MODEL CHART

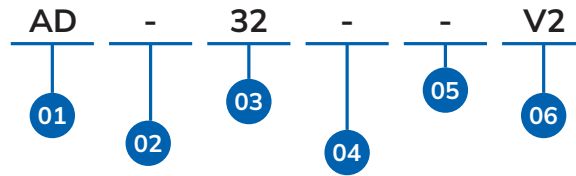

01	SERIES
	AD

02	PRODUCT TYPE
-	Double Acting Actuator

03	BORE Ø (mm)
032	32
040	40
050	50
063	63
080	80
100	100
125	125
150	150
175	175
200	200
250	250
300	300
350	350

04	ROTATION
-	90 CCW
C	90 CW

05	CONFIGURATION
-	REGULAR
C1	CONFIG 1
C2	CONFIG 2
C3	CONFIG 3
⋮	⋮
C9	CONFIG 9
CA	CONFIG 10
CB	CONFIG 11

06	VERSION
-	VERSION 0
V1	VERSION 1
V2	VERSION 2
V3	VERSION 3
⋮	⋮
V9	VERSION 9
VA	VERSION 10
VB	VERSION 11

AD-32V2
DOUBLE ACTING ACTUATOR SIZE 32 ALUMINIUM-NITRILE-90 CCW-VERSION 2

Note: The above chart is for identification purposes only, and it may not be possible to make all combinations for the above chart.

AS - SERIES SINGLE ACTING ROTARY ACTUATOR MODEL CHART

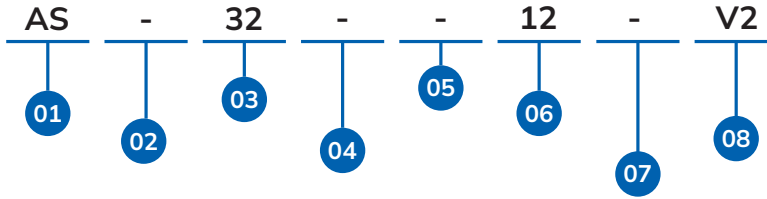

01	SERIES
	AS

02	PRODUCT TYPE
-	Single Acting Actuator

03	SIZE
32	32
40	40
50	50
63	63
80	80
90	90
100	100
110	110
125	125
150	150
175	175
200	200
250	250
300	300
350	350

04	SEAL MATERIAL
-	NITRILE
E	EPDM
V	VITON

05	ROTATION
-	90 CCW
C	90 CW

07	CONFIGURATION
-	REGULAR
C1	CONFIG 1
C2	CONFIG 2
C3	CONFIG 3
⋮	⋮
C9	CONFIG 9
CA	CONFIG 10
CB	CONFIG 11

08	VERSION
-	VERSION 0
V1	VERSION 1
V2	VERSION 2
V3	VERSION 3
⋮	⋮
V9	VERSION 9
VA	VERSION 10
VB	VERSION 11

06 SPRING SET									
SPRING SET 32 TO 63			SPRING SET - 80 & 90				SPRING SET 100 TO 350		
CODE	INNER	OUTER	CODE	INNER	MIDDLE	OUTER	CODE	BLACK SPRING	WHITE SPRING
02	0	2	201	2	0	1	12	12	0
21	2	1	211	2	1	1	6U	6	1
12	1	2	121	1	2	1	8U	8	1
22	2	2	112	1	1	2	12U	12	1
⋮	⋮	⋮	212	2	1	2	13U	13	1
			222	2	2	2	11	11	0
			⋮	⋮	⋮	⋮	09	9	0
							14	14	0
							7U2	7	2
							10	10	0
							7U	7	1
							⋮	⋮	⋮

AS-3212V2
SINGLE ACTING ACTUATOR SIZE 32 ALUMINIUM-NITRILE-90 CCW
-WITH SPRING SET NO 12-VERSION 2

Note : The above chart is for identification purposes only, and it may not be possible to make all combinations for the above chart.



**BALL VALVE
SERIES**

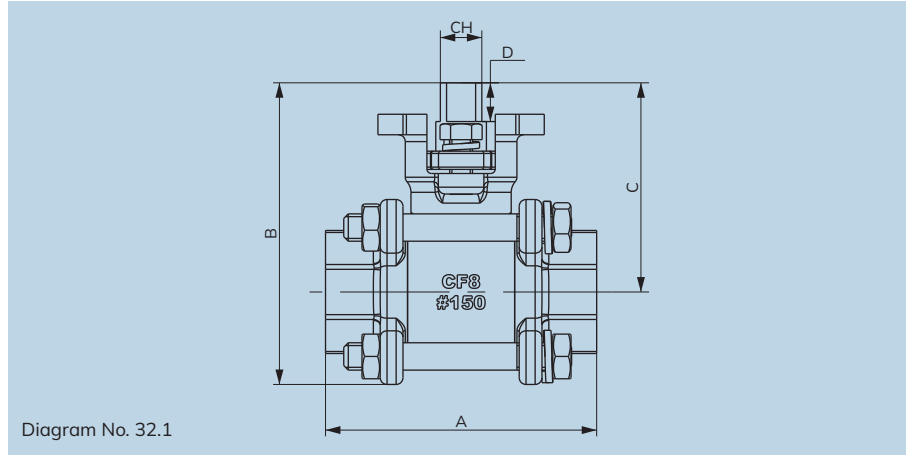

Specifications

Size :	DN15 - DN100
End Connection :	Screwed end (BSP / NPT), Socket Weld
Face to Face :	MFG. Standard
Design Standard :	ASME B16.11, ASME B16.34, API 598, BS EN ISO 17292, ISO 5211
Pressure Class :	150#, 300#
Body Material :	CF8 / CF8M / WCB / CF3M
Pipe End Material :	CF8 / CF8M / WCB / CF3M
Ball Material :	CF8 / CF8M
Body Seal Material :	PTFE / RPTFE / CFT / GFT / PEEK
Seat Ring Material :	PTFE / RPTFE / CFT / GFT / PEEK
Fastener Material :	SS304 / SS316
Stem Seal Material :	PTFE / RPTFE / CFT / GFT / PEEK
Stem Material :	SS304 / SS316 / SS410
Gland Bush Material :	SS304 / SS316 / SS410
Gland Material :	SS304 / SS316 / SS410

Features

- 3PC design twinseal ball valve.
- Full port ball valve.
- Blow out proof stem.
- Floating ball design.
- Hand Lever / Gear / Actuator Operated.
- Face to Face:- MFG standard.
- End Connection:- Screwed / Socket weld (ASME B16.11).
- Balls are precision machined and mirror finished for bubble-tight shut off with less operating torque.
- ISO 5211 top mounting pad available for easy Uflow make actuator mounting.

Section View

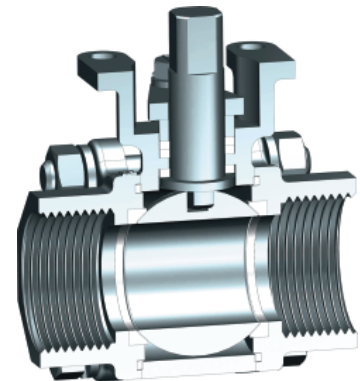

All dimensions are approx.

Dimension (All dimensions in mm)

Model No.	Diagram No.	Pipe (Inch)	A	B	CH	D	C	ISO 5211
JC-2R	32.1	½"	59.50	66	9.1	8.5	46	F03
JC-3R	32.1	¾"	57	71	9.1	9	50	F03
JC-4R	32.1	1"	75.70	90	11	13.5	61.5	F05
JC-5R	32.1	1¼"	85	102.7	11	13	70	F05
JC-6R	32.1	1½"	93.60	110	11	13	73.5	F05
JC-8R	32.1	2"	109	139.6	14	15.5	94	F05
JC-9R	32.1	2½"	139	173	14	15	108.5	F07
JC-AR	32.1	3"	166	195	17	16.5	119.5	F07
JC-BR	32.1	4"	193	236	22	23	144	F07

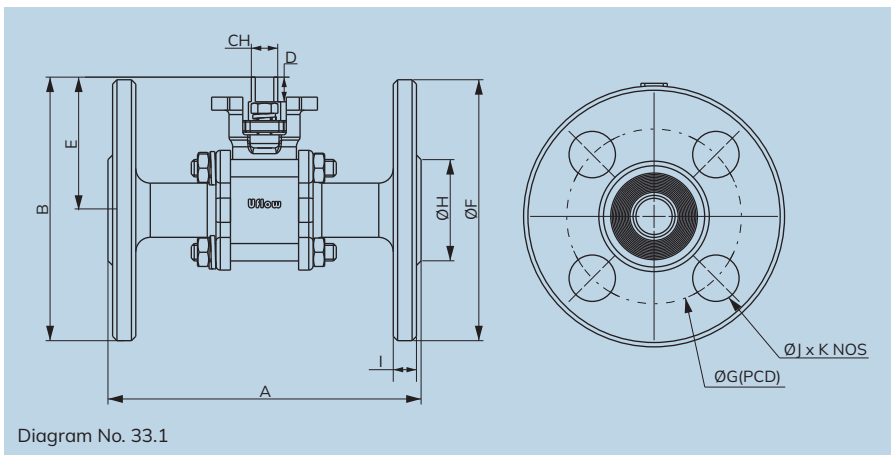

Specifications

Size :	DN15 - DN100
End Connection :	Flange end
Face to Face :	ASME B 16.10 (Flange end)
Pressure Class :	150#, 300#
Design Standard :	ASME B16.10, ASME B16.25, ASME B16.34, ASME B16.5, API 598, BS EN ISO 17292, ISO 5211
Body Material :	CF8 / CF8M / WCB / CF3M
Tail Piece Material :	CF8 / CF8M / WCB / CF3M
Ball Material :	CF8 / CF8M
Body Seal Material :	PTFE / RPTFE / CFT / GFT / PEEK
Seat Ring Material :	PTFE / RPTFE / CFT / GFT / PEEK
Fastener Material :	SS304 / SS316
Stem Seal Material :	PTFE / RPTFE / CFT / GFT / PEEK
Stem Material :	SS304 / SS316 / SS410
Gland Bush Material :	SS304 / SS316 / SS410
Gland Material :	SS304 / SS316 / SS410

Features

- 3PC design twinseal ball valve.
- Full port ball valve.
- Blow out proof stem.
- Floating ball design.
- Hand Lever / Gear / Actuator Operated.
- Face to Face:- ASME B16.10.
- End Connection:- Flanged (ASME B16.5), Butt-weld (ASME B16.25)
- Balls are precision machined and mirror finished for bubble-tight shut off with less operating torque.
- ISO 5211 top mounting pad available for easy Uflow make actuator mounting.

Section View

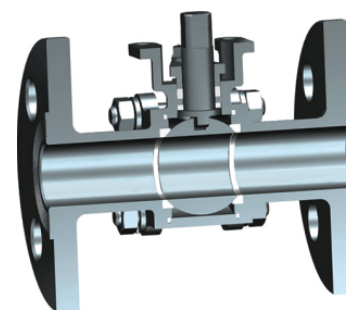

Dimension (All dimensions in mm)

All dimensions are approx.

Model No.	Diagram No.	Pipe (Inch)	A	B	CH	D	E	F	G	H	I	J	K	ISO 5211
JC-2DR	33.1	½"	108	91	9.1	8.5	46	90	60.5	35	8	16	4	F03
JC-3DR	33.1	¾"	117	100	9.1	9	50	100	70	44.5	9	16	4	F03
JC-4DR	33.1	1"	127	117	11	13.5	61.5	110	79.5	48	9.6	16	4	F05
JC-5DR	33.1	1¼"	140	127	11	13	70	115	89	63.5	11.2	16	4	F05
JC-6DR	33.1	1½"	165	136	11	13	73.5	125	98.5	73	12.5	16	4	F05
JC-8DR	33.1	2"	178	169	14	15.5	94	150	121	92	14.5	19	4	F05
JC-9DR	33.1	2½"	190	198.5	14	15	108.5	180	139.5	105	16	19.5	4	F07
JC-ADR	33.1	3"	203	214.5	17	16.5	119.5	190	152.5	127	17.5	19.5	4	F07
JC-BDR	33.1	4"	229	259	22	23	144	230	190.5	157	22.5	19	8	F07

JC -SERIES 3 PC BALL VALVE FULL BORE MODEL CHART

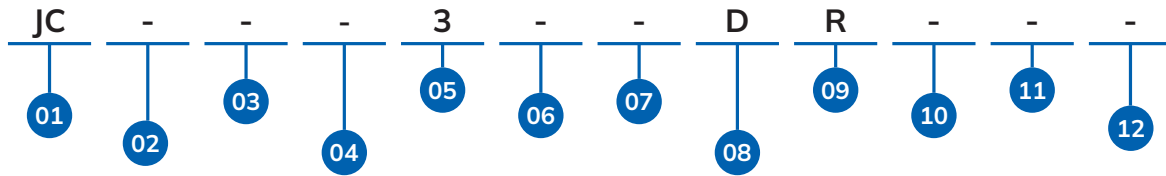

01	SERIES
-	JC

02	PRODUCT TYPE
-	3PC Ball Valve Full Bore

03	BODY MATERIAL
-	CF8
M	CF8M
V	CF3M
F	CF3
W	WCB
J	WCB-MR0103
H	WCB-MR0175

04	SEAL MATERIAL
-	PTFE
R	RPTFE
T	CFT
L	GFT
K	PEEK
P	PCTFE

05	PORT SIZE
2	1/2"
3	3/4"
4	1"
5	1-1/4"
6	1-1/2"
7	3/8"
8	2"
9	2-1/2"
A	3"
B	4"

06	STEM/BALL MATERIAL
-	CF8/SS 304
M	CF8M/SS 316
V	CF3M/SS 316L
F	CF3/SS 304L

07	PRESSURE CLASS
-	150#
B	300#
1	PN40

08	PORT CONNECTION
-	BSP
N	NPT
P	BSPT
D	Flange End
T	Tri Clamp
S	Socket
W	Buttweld
A	Flat Face Flange End

09	OPERATION
-	Actuator Operated
R	Bare Stem
E	Electric Actuator Operated
G	Gear
U	Manual Operated
L	Manual With Limit Switch
4	Manual Operated Ss304

10	APPROVALS
-	NO APPROVALS

11	CONFIG
-	REGULAR
C1	CONFIG 1
C2	CONFIG 2
C3	CONFIG 3
⋮	⋮
C9	CONFIG 9
CA	CONFIG 10
CB	CONFIG 11

12	VERSION
-	VERSION 0
V1	VERSION 1
V2	VERSION 2
V3	VERSION 3
⋮	⋮
V9	VERSION 9
VA	VERSION 10
VB	VERSION 11

JC-3DR
3/4" 3PC BALL VALVE FULL BORE CF8-PTFE-CF8/SS304-150#-
FLANGE END-BARE STEM

Note : The above chart is for identification purposes only, and it may not be possible to make all combinations for the above chart.



**BUTTERFLY VALVE
SERIES**

Specifications

End Connection :	Wafer - API 609 (CAT - A)
Size :	DN40 - DN300
Suitable :	ASME B16.5 150#
Pressure Range :	PN06, PN10, PN16
Leakage Class :	100% Tightness at fully differential pressure
Standard :	API 609, BS 5155, ISO 5211, API 598, ASME B16.5
Body Material :	Cast Iron(CI), SGI, WCB, CF8, CF8M
Disc Material :	SGI, CF8, CF8M, WCB
Stem Material :	SS410, SS304, SS316
Body Liner / Seat Material :	NBR, EPDM, VITON
Shaft Bearing Material :	PTFE

Features

- ☑ Bi-directional zero leakage butterfly valve.
- ☑ ISO Pad for mounting, Gear Operator / Actuator
- ☑ Extremely small play between the stem and disc due to 'Double D' drive.
- ☑ Accurate dual stem sealing prevents leakage.
- ☑ Butterfly valve can be mounted between flanges as per ASME.
- ☑ 100% Tested With Pneumatic And Fluid (Water) Media.
- ☑ Design Standard : ISO 5211, API 609, ASME B16.5 150#.
- ☑ Face to Face Dimension : API 609 (CAT A).
- ☑ Operator mounting flange : As per ISO 5211.
- ☑ Operator : Hand Lever / Gear / Actuator
- ☑ Leakage Class : 100% tightness at full differential Pressure.

Hand Lever Operated Wafer Type Butterfly Valve

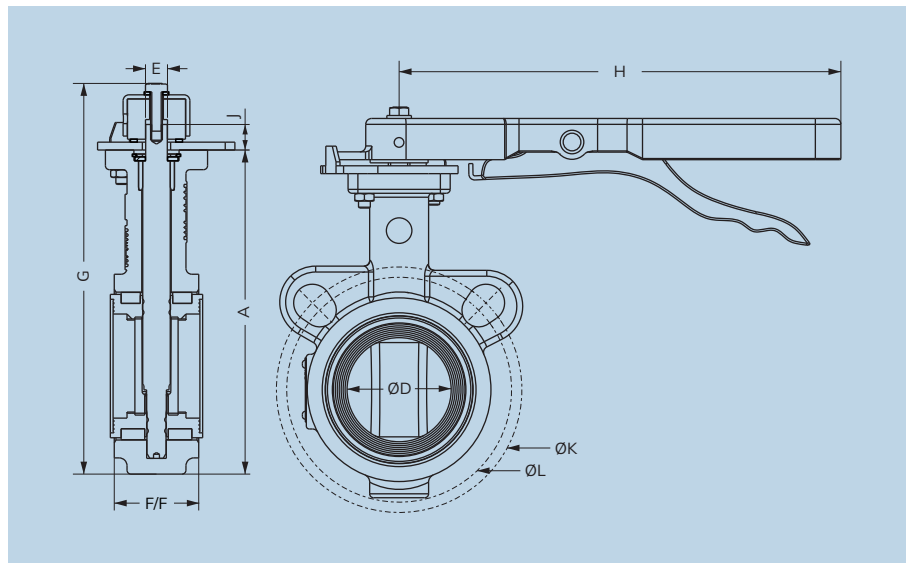

Technical Data (All dimensions are in mm)

All dimensions are approx.

Size	A	ØD	F/F	ØK	ØL	G	J	H	E	MOUNTING FLANGE
40 MM	140	40	33	105	98	173	12	225	11	F05
50 MM	165	50	43	125	114	199	13	225	11	F05
65 MM	192	65	46	145	127	226	12	225	11	F05
80 MM	218	80	46	164	146	252	14	225	11	F05
100 MM	243	100	52	190	179	275	17	260	14	F07
125 MM	276	125	56	216	200	310	20	260	17	F07
150 MM	310	150	56	241	225	344	19	260	17	F07
200 MM	404	200	60	298	292	442	22	290	22	F07/F10
250 MM	470	250	68	362	350	510	25	290	22	F07/F10

Pneumatic Operated Wafer Type Butterfly Valve - PN10

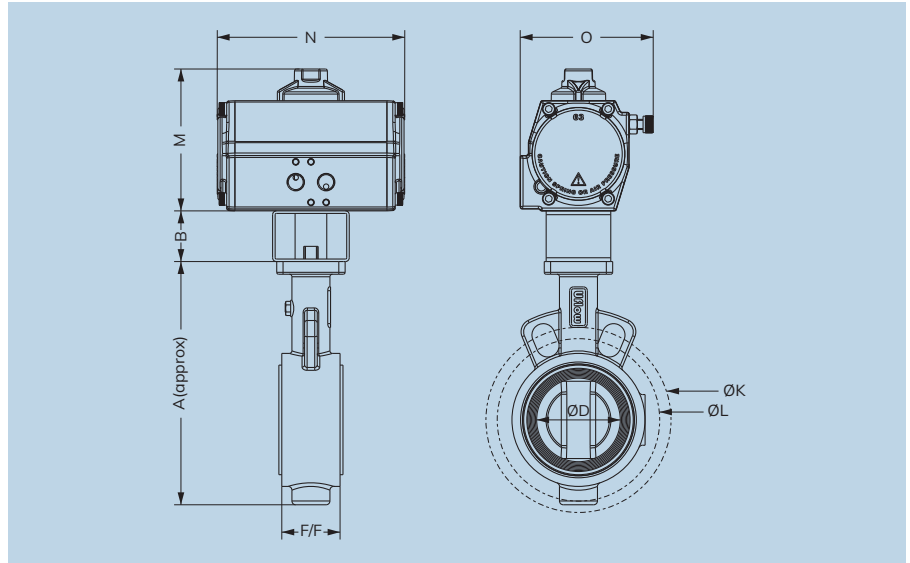

Technical Data - Butterfly Valve with Double Acting Actuator (All dimensions are in mm)

All dimensions are approx.

Size	Actuator	Coupler	A	B	ØD	F/F	ØK	ØL	M	N	O	Mounting Flange
40 MM	50	NA	140	-	40	33	105	98	99	130	85	F05
50 MM	50	NA	165	-	50	43	125	114	99	130	85	F05
65 MM	50	NA	192	-	65	46	145	127	99	130	85	F05
80 MM	50	NA	218	-	80	46	164	146	99	130	85	F05
100 MM	63	NA	243	-	100	52	190	179	112	147	105	F07
125 MM	80	NA	276	-	125	56	216	200	128	170	114	F07
150 MM	80	NA	310	-	150	56	241	225	128	170	114	F07
200 MM	100	NA	404	-	200	60	298	292	154	220	150	F07/F10
250 MM	125	NA	470	-	250	68	362	350	185	389	174	F07/F10
300 MM	150	NA	562	-	300	78	432	400	219	465	205	F12

Technical Data - Butterfly Valve with Single Acting Actuator (All dimensions are in mm)

All dimensions are approx.

Size	Actuator	Coupler	A	B	ØD	F/F	ØK	ØL	M	N	O	Mounting Flange
40 MM	50	NA	140	-	40	33	105	98	99	162	85	F05
50 MM	50	NA	165	-	50	43	125	114	99	162	85	F05
65 MM	63	C1455V0	192	40	65	46	145	127	112	202	105	F05
80 MM	80	C1755V0	218	40	80	46	164	146	128	234	114	F05
100 MM	100	C4277V0	243	40	100	52	190	179	153	324	151	F07
125 MM	100	C7277V0	276	40	125	56	216	200	153	324	151	F07
150 MM	125	C7270V0	310	61	150	56	241	225	185	389	173	F07
200 MM	150	C2800V0	404	61	200	60	298	292	219	465	205	F07/F10
250 MM	150	C2800V0	470	61	250	68	362	350	219	465	205	F07/F10

Pneumatic Operated Wafer Type Butterfly Valve - PN16

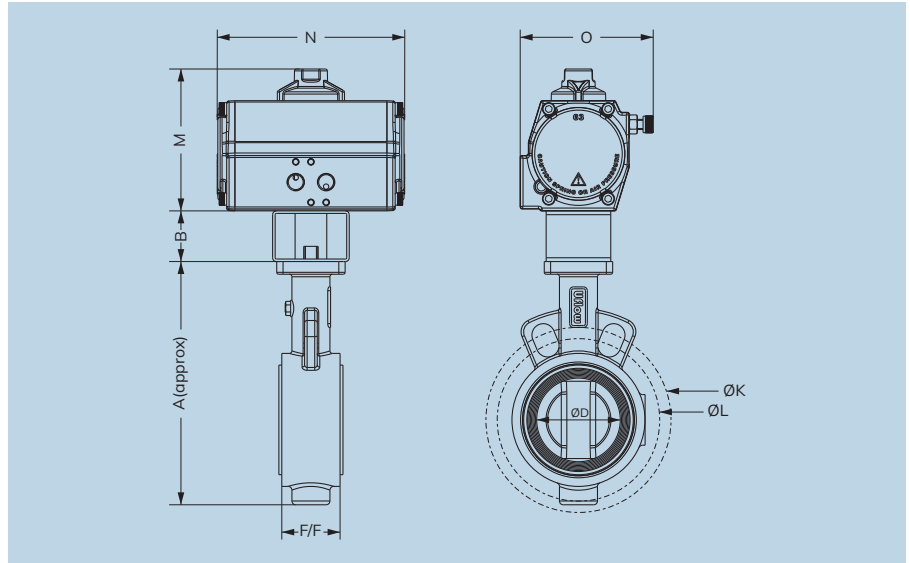

Technical Data - Butterfly Valve With Double Acting Actuator (All dimensions are in mm)

All dimensions are approx.

Size	Actuator	Coupler	A	B	ØD	F/F	ØK	ØL	M	N	O	Mounting Flange
40 MM	50	NA	140	-	40	33	105	98	99	130	85	F05
50 MM	50	NA	165	-	50	43	125	114	99	130	85	F05
65 MM	50	NA	192	-	65	46	145	127	99	130	85	F05
80 MM	63	C1455V0	218	40	80	46	164	146	112	147	105	F05
100 MM	80	C4777V0	243	40	100	52	190	179	128	170	114	F07
125 MM	80	NA	276	-	125	56	216	200	128	170	114	F07
150 MM	100	C7277V0	310	40	150	56	241	225	154	220	150	F07
200 MM	125	NA	404	-	200	60	298	292	185	389	174	F07/F10
250 MM	150	C2800V0	470	61	250	68	362	350	219	465	205	F07/F10

Technical Data - Butterfly Valve With Single Acting Actuator (All dimension are in mm)

All dimensions are approx.

Size	Actuator	Coupler	A	B	ØD	F/F	ØK	ØL	M	N	O	Mounting Flange
40 MM	63	C1455V0	140	40	40	33	105	98	112	202	105	F05
50 MM	80	C1755V0	165	40	50	43	125	114	128	234	114	F05
65 MM	80	C1755V0	192	40	65	46	145	127	128	234	114	F05
80 MM	100	C1257V0	218	40	80	46	164	146	153.5	324	151	F05
100 MM	100	C4277V0	243	40	100	52	190	179	153.5	324	151	F07
125 MM	125	C7270V0	276	61	125	56	216	200	185	389	173	F07
150 MM	150	C7870V0	310	61	150	56	241	225	219	465	205	F07

Gear Box Operated Wafer Type Butterfly Valve

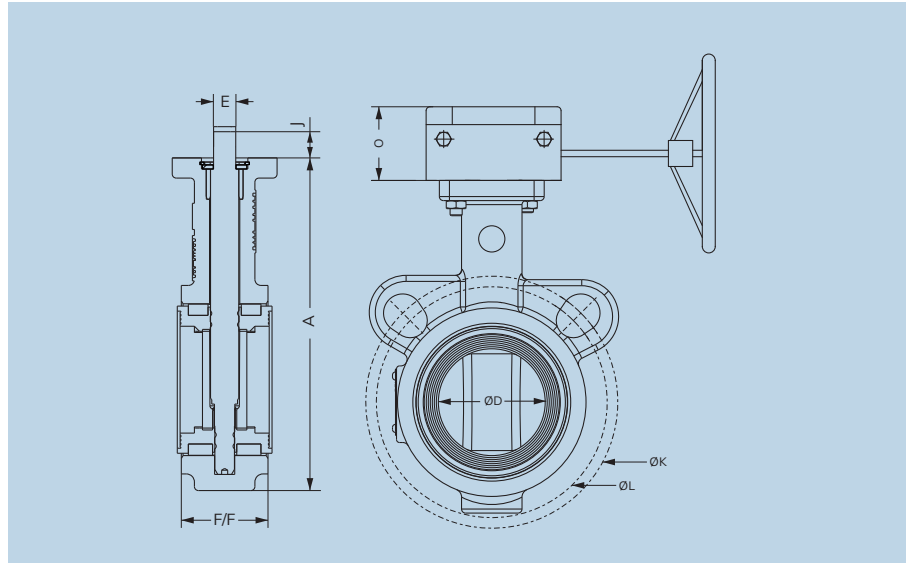

Technical Data (All dimensions are in mm)

All dimensions are approx.

Size	A	ØD	F/F	ØK	ØL	E	J	O	Mounting Flange
40 MM	140	40	33	105	98	11	12	50	F05
50 MM	165	50	43	125	114	11	13	50	F05
65 MM	192	65	46	145	127	11	12	50	F05
80 MM	218	80	46	164	146	11	14	50	F05
100 MM	243	100	52	190	179	14	17	53	F07
125 MM	276	125	56	216	200	17	20	53	F07
150 MM	310	150	56	241	225	17	19	53	F07
200 MM	404	200	60	298	292	22	22	63	F07/F10
250 MM	470	250	68	362	350	22	25	63	F07/F10
300 MM	561	300	78	432	399	27	32	70	F12

Applicable Flange Mounting

SIZE	ANSI	DIN 1092			BS10			JIS		
	150#	PN6	PN10	PN16	TABLE-E	TABLE-F	TABLE-H	5K	10K	16K
DN40	OK	OK	NA	NA	OK	OK	OK	NA	OK	NA
DN50	OK	OK	OK	OK	OK	OK	OK	NA	OK	NA
DN65	OK	OK	OK	OK	OK	OK	OK	OK	OK	OK
DN80	OK	OK	OK	OK	OK	OK	OK	OK	OK	NA
DN100	OK	NA	OK	OK	OK	OK	OK	NA	NA	NA
DN125	OK	OK	OK	OK	OK	NA	NA	OK	NA	NA
DN150	OK	OK	OK	OK	OK	NA	NA	OK	OK	NA
DN200	OK	NA	OK	OK	OK	NA	NA	NA	NA	NA
DN250	OK	NA	OK	NA	OK	NA	NA	NA	OK	NA
DN300	OK	NA	OK	NA	OK	NA	NA	NA	NA	NA

BW - SERIES BUTTERFLY VALVE WAFER TYPE MODEL CHART

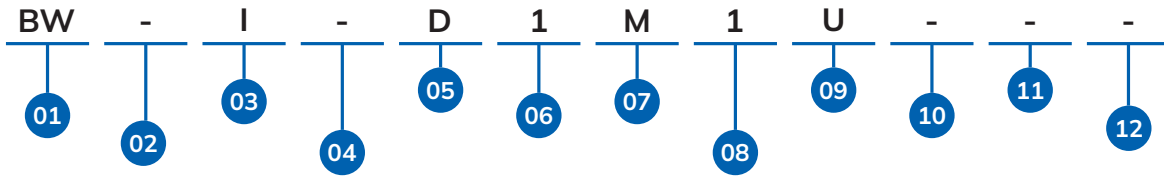

01	SERIES
-	BW

02	PRODUCT TYPE
-	Butterfly Valve Wafer Type

03	BODY MATERIAL
-	CF8
I	CI
S	SGI
K	Ductile Iron
W	WCB
M	CF8M
V	CF3M

04	SEAL MATERIAL
-	EPDM
N	NBR
T	VITON
L	SILICONE
U	BUNA N
2	EPDM FG

05	PORT SIZE
6	1-1/2"
8	2"
9	2-1/2"
A	3"
B	4"
C	5"
D	6"
E	8"
F	10"
G	12"

06	PRESSURE CLASS
1	PN10
2	PN16
3	PN6

07	DISC MATERIAL
-	CF8
M	CF8M
W	WCB
S	SGI
K	Ductile Iron
V	CF3M

08	STEM MATERIAL
-	SS 304
1	SS 410
3	SS 316L
6	SS 316
8	SS 416

09	OPERATION
-	Actuator Operated
R	Bare Stem
U	Manual Operated
G	Gear Operated
4	Manual Operated SS304
E	Electric Actuator Operated
L	Actuator With Lever
A	Actuator With Gear

10	APPROVALS
-	NO APPROVALS

11	CONFIG
-	REGULAR
C1	CONFIG 1
C2	CONFIG 2
C3	CONFIG 3
⋮	⋮
C9	CONFIG 9
CA	CONFIG 10
CB	CONFIG 11

12	VERSION
-	VERSION 0
V1	VERSION 1
V2	VERSION 2
V3	VERSION 3
⋮	⋮
V9	VERSION 9
VA	VERSION 10
VB	VERSION 11

BW-ID1M1U
6" BUTTERFLY VALVE WAFER TYPE CI-EPDM-PN10-
CF8M-SS410-MANUAL OPERATED

Note : The above chart is for identification purposes only, and it may not be possible to make all combinations for the above chart.

Specifications

End Connection :	Lug
Size :	DN50 - DN300
Suitable :	ASME B16.5 150#
Pressure Range :	PN06, PN10, PN16
Leakage Class :	100% Tightness at fully differential pressure
Standard :	API 609, BS 5155, ISO 5211, API 598, ASME B16.5
Body Material :	Cast Iron(CI), SGI, WCB, CF8, CF8M
Disc Material :	SGI, CF8, CF8M, WCB
Stem Material :	SS410, SS304, SS316
Body Liner / Seat Material :	NBR, EPDM, VITON
Shaft Bearing Material :	PTFE

Features

- ☑ Bi-directional zero leakage butterfly valve.
- ☑ ISO Pad for mounting, Gear Operator / Actuator
- ☑ Extremely small play between the stem and disc due to 'Double D' drive.
- ☑ Accurate dual stem sealing prevents leakage.
- ☑ Standard flanged drilling : PN10/PN16, JIS 10K/16K, ASME 125/150#
- ☑ 100% Tested With Pneumatic And Fluid (Water) Media.
- ☑ Design Standard : ISO 5211, API 609, ASME B16.5 150#.
- ☑ Face to Face Dimension : API 609 (CAT A).
- ☑ Operator mounting flange : As per ISO 5211.
- ☑ Operator : Hand Lever / Gear / Actuator
- ☑ Leakage Class : 100% tightness at full differential Pressure.

Hand Lever Operated Lug Type Butterfly Valve

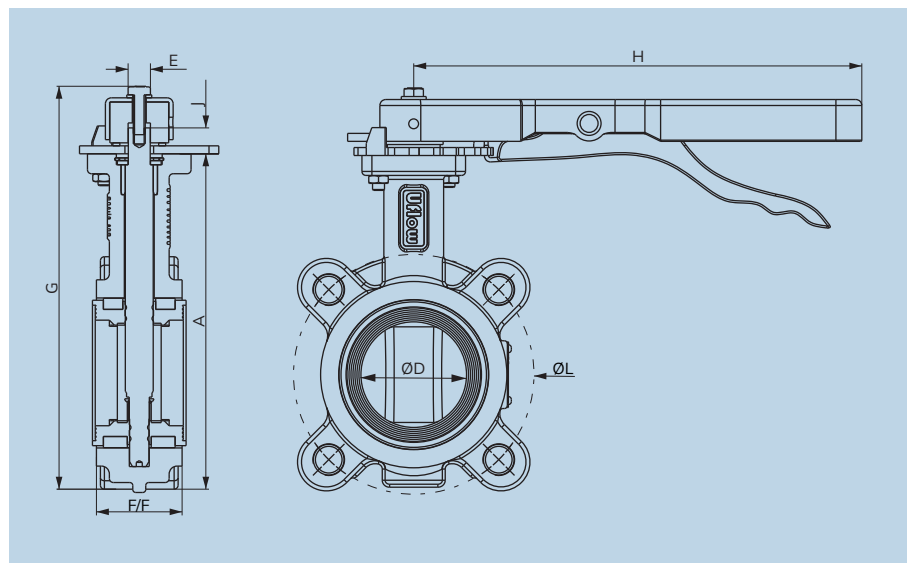

Technical Data (All dimensions are in mm)

All dimensions are approx.

Size	A	ØD	F/F	ØL	G	J	H	E	MOUNTING FLANGE
50 MM	170	50	43	120	204	13	225	11	F05
65 MM	192	65	46	140	226	12	225	11	F05
80 MM	219	80	46	152.5	252	14	225	11	F05
100 MM	258	100	52	190.5	289	17	260	14	F07
125 MM	287	125	56	216	320	20	260	17	F07
150 MM	318	150	56	241	353	19	260	17	F07
200 MM	393	200	60	298	431	22	290	22	F10
250 MM	465	250	68	362	505	25	290	22	F10

Pneumatic Operated Lug Type Butterfly Valve - PN10

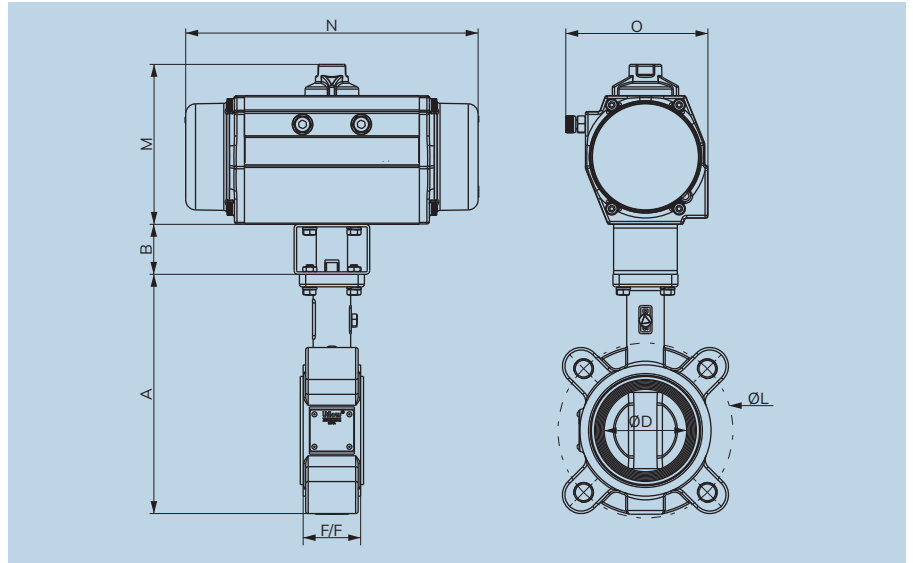

Technical Data - Butterfly Valve with Double Acting Actuator (All dimensions are in mm)

All dimensions are approx.

Size	Actuator	Coupler	A	B	ØD	F/F	ØL	M	N	O	Mounting Flange
50 MM	50	NA	170	-	50	43	120	99	130	85	F05
65 MM	50	NA	192	-	65	46	140	99	130	85	F05
80 MM	50	NA	219	-	80	46	152.5	99	130	85	F05
100 MM	63	NA	258	-	100	52	190.5	112	147	105	F07
125 MM	80	NA	287	-	125	56	216	128	170	114	F07
150 MM	80	NA	318	-	150	56	241	128	170	114	F07
200 MM	100	NA	393	-	200	60	298	154	220	150	F10
250 MM	125	NA	465	-	250	68	362	185	389	174	F10
300 MM	150	NA	552	-	300	78	432	219	465	205	F12

Technical Data - Butterfly Valve with Single Acting Actuator (All dimensions are in mm)

All dimensions are approx.

Size	Actuator	Coupler	A	B	ØD	F/F	ØL	M	N	O	Mounting Flange
50 MM	50	NA	170	-	50	43	120	99	162	84.9	F05
65 MM	63	C1455V0	192	40	65	46	140	112	202	105	F05
80 MM	80	C1755V0	219	40	80	46	152.5	128	234	114	F05
100 MM	100	C4277V0	258	40	100	52	190.5	153	324	151	F07
125 MM	100	C7277V0	287	40	125	56	216	153	324	151	F07
150 MM	125	C7270V0	318	61	150	56	241	185	389	173	F07
200 MM	150	C2800V0	393	61	200	60	298	219	465	205	F10
250 MM	150	C2800V0	465	61	250	68	362	219	465	205	F10

Pneumatic Operated Lug Type Butterfly Valve - PN16

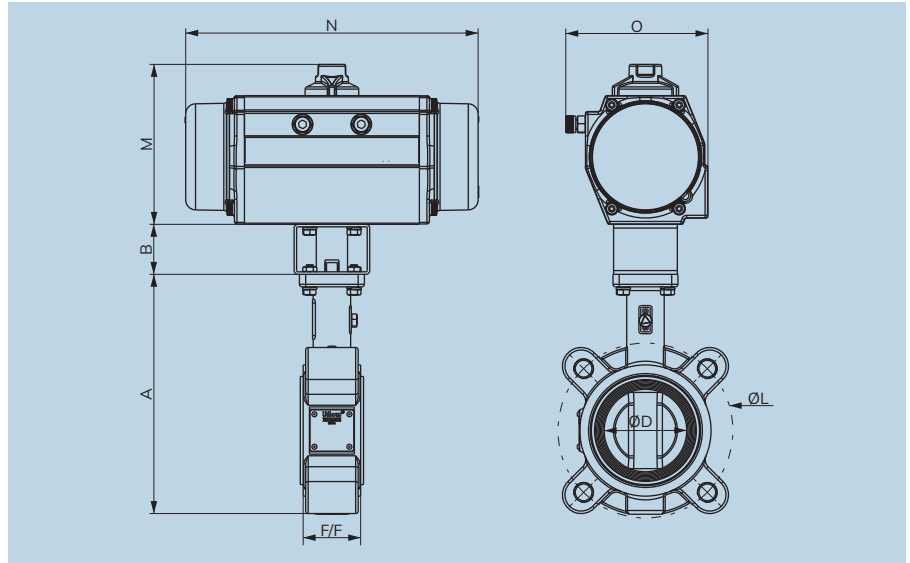

Technical Data - Butterfly Valve with Double Acting Actuator (All dimensions are in mm)

All dimensions are approx.

Size	Actuator	Coupler	A	B	ØD	F/F	ØL	M	N	O	Mounting Flange
50 MM	50	NA	170	-	50	43	120	99	130	85	F05
65 MM	50	NA	192	-	65	46	140	99	130	85	F05
80 MM	63	C1455V0	219	40	80	46	152.5	112	147	105	F05
100 MM	80	C4777V0	258	40	100	52	190.5	128	170	114	F07
125 MM	80	NA	287	-	125	56	216	128	170	114	F07
150 MM	100	C7277V0	318	40	150	56	241	154	220	150	F07
200 MM	125	NA	393	-	200	60	298	185	389	173	F10
250 MM	150	C2800V0	465	61	250	68	362	219	465	205	F10

Technical Data - Butterfly Valve with Single Acting Actuator (All dimension are in mm)

All dimensions are approx.

Size	Actuator	Coupler	A	B	ØD	F/F	ØL	M	N	O	Mounting Flange
50 MM	80	C1755V0	170	40	50	43	120	128	234	114	F05
65 MM	80	C1755V0	192	40	65	46	140	128	234	114	F05
80 MM	100	C1257V0	219	40	80	46	152.5	153.5	324	151	F05
100 MM	100	C4277V0	258	40	100	52	190.5	153.5	324	151	F07
125 MM	125	C7270V0	287	61	125	56	216	185	389	173	F07
150 MM	150	C7870V0	318	61	150	56	241	219	465	205	F07

Gear Box Operated Lug Type Butterfly Valve

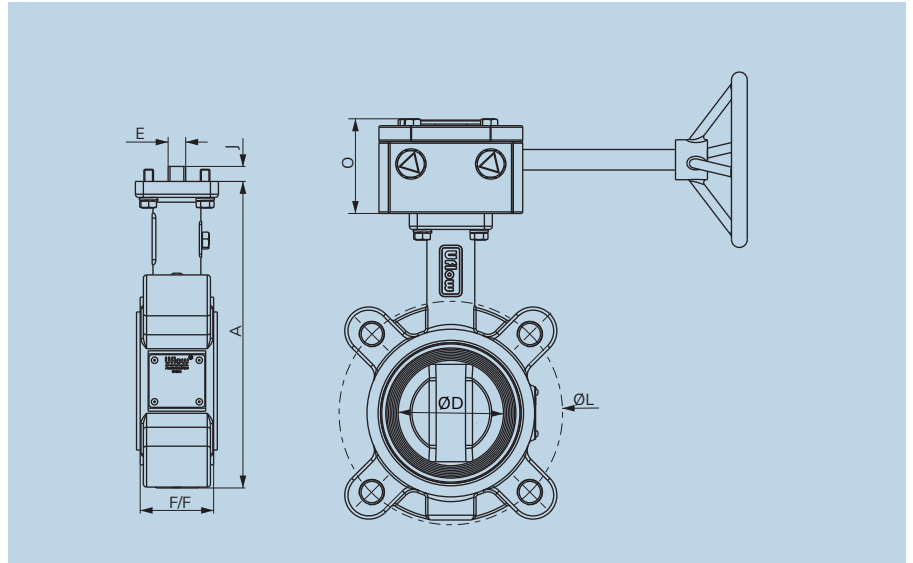

Technical Data (All dimensions are in mm)

All dimensions are approx.

Size	A	ØD	F/F	ØL	E	J	O	Mounting Flange
50 MM	170	50	43	120	11	13	50	F05
65 MM	192	65	46	140	11	12	50	F05
80 MM	219	80	46	153	11	14	50	F05
100 MM	258	100	52	191	14	17	53	F07
125 MM	287	125	56	216	17	20	53	F07
150 MM	318	150	56	241	17	19	53	F07
200 MM	393	200	60	298	22	22	63	F10
250 MM	465	250	68	362	22	25	63	F10
300 MM	552	300	78	432	27	32	70	F12

BL - SERIES LUG TYPE BUTTERFLY VALVE MODEL CHART

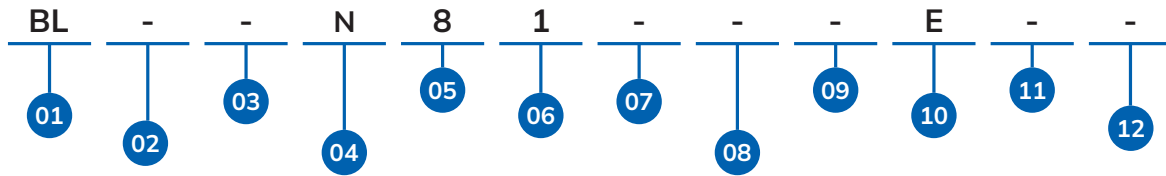

01	SERIES
BL	

02	PRODUCT TYPE
-	Butterfly Valve Lug Type

03	BODY MATERIAL
-	CF8
I	CI
S	SGI
K	Ductile Iron
W	WCB
M	CF8M
V	CF3M

04	SEAL MATERIAL
-	EPDM
N	NBR
T	VITON
L	SILICONE
U	BUNA N
Z	EPDM FG

05	PORT SIZE
8	2"
9	2-1/2"
A	3"
B	4"
C	5"
D	6"
E	8"
F	10"
G	12"

06	PRESSURE CLASS
1	PN10
2	PN16
3	PN6

07	FLANGE SELECTION
-	150 # PCD
B	PN10 PCD
C	PN16 PCD
D	10K PCD
F	16K PCD
H	AS2129 Table E

08	DISC MATERIAL
-	CF8
M	CF8M
W	WCB
S	SGI
K	Ductile Iron
V	CF3M

09	STEM MATERIAL
-	SS 304
N	SS 410
P	SS 316L
D	SS 316
T	SS 416

10	OPERATION
-	Actuator Operated
R	Bare Stem
E	Manual Operated
G	Gear Operated
U	Manual Operated Ss304
L	Electric Actuator Operated
4	Actuator With Gear

11	APPROVALS
-	NO APPROVALS

12	CONFIG
-	REGULAR
C1	CONFIG 1
C2	CONFIG 2
C3	CONFIG 3
⋮	⋮
C9	CONFIG 9
CA	CONFIG 10
CB	CONFIG 11

13	VERSION
-	VERSION 0
V1	VERSION 1
V2	VERSION 2
V3	VERSION 3
⋮	⋮
V9	VERSION 9
VA	VERSION 10
VB	VERSION 11

BL-N81E
8" LUG TYPE BUTTERFLY VALVE CF8-NBR-PN10-CF8-SS410-150# PCD-MANUAL OPERATED



**LIMIT SWITCH
SERIES**



Features for Compact Limit Switch - LC Series

- ☑ Compact & Lightweight design
- ☑ Open / Close indicator visible from all directions.
- ☑ No extra attachment required for the indicator dome as it is inbuilt with a transparent cover.
- ☑ Cable entries with multiple connectivity option (M20 & 1/2" NPT).
- ☑ A stainless steel bracket is available as an option.
- ☑ Every adjustable serrated cam for fast & Fine switch adjustment & Also helpful for fine adjusting of feedback setting.
- ☑ Temperature range -20°C to +80°C

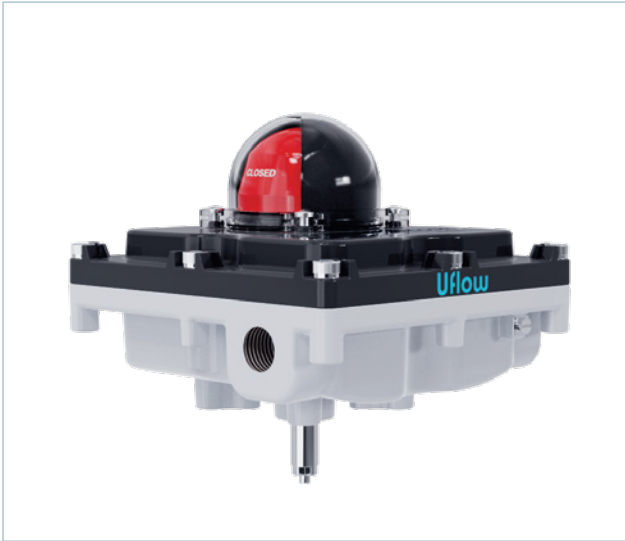

Features for Standard Limit Switch - LS Series

- ☑ Honeywell/ Cherry Microwitch Sensors
- ☑ Exproof to I, IIA, IIB, and IIC
- ☑ Aluminium Diecast, with powder coating, for superior corrosion resistance
- ☑ Easily settable colour coded cam
- ☑ The locked serrated cams, ensures the secured settings against any vibration
- ☑ Switch Box conforms to Ex d IIC, T6 Highest level of safety
- ☑ Special PCB eliminates all wiring from the switch element to the terminals. Complete protection against short circuit
- ☑ Temperature range -20 °C to +80 °C
- ☑ IP67 : Water, Rain and Dust Proof
- ☑ IP68 : Upto 100m on request
- ☑ Cable Entry M20, 1/2" NPT or 3/4" NPT
- ☑ ATEX EX d IIC, T6
- ☑ Shatterproof Polycarbonate Dome
- ☑ All fasteners are in Stainless Steel
- ☑ Up to Maximum 4 Sensor Elements

Dimension Drawing for Compact Limit Switch

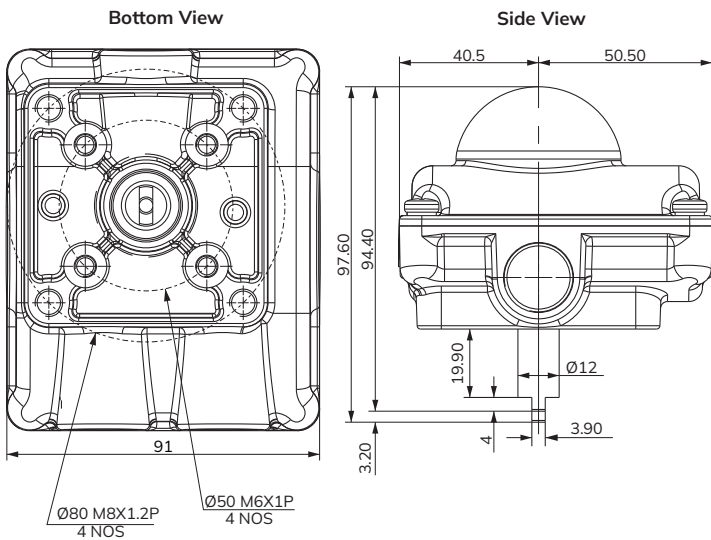

Dimension Drawing for Standard Limit Switch

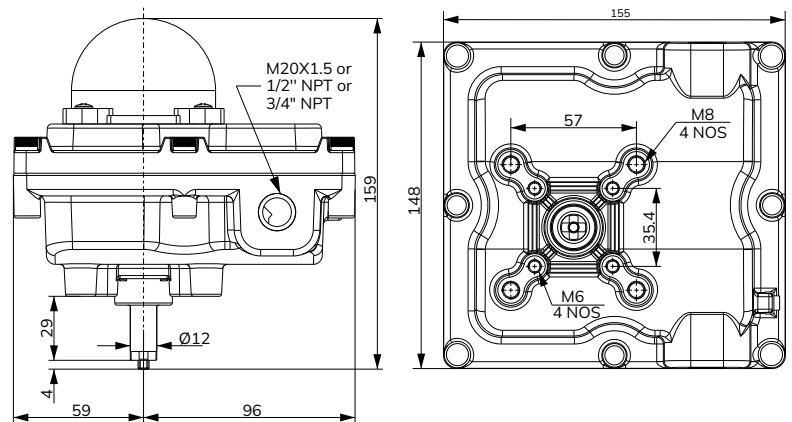

All dimensions in mm
All dimensions are approx.

LC - SERIES LIMIT SWITCH MODEL IDENTIFICATION CHART

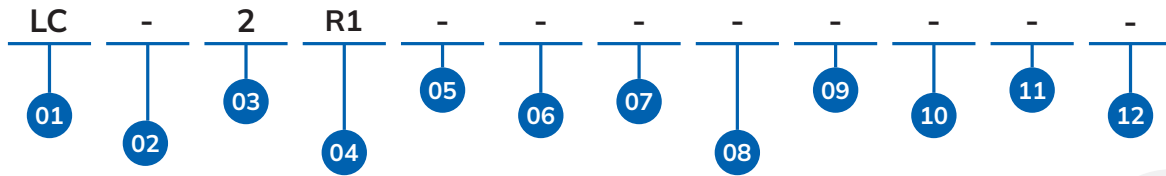

01	SERIES
-	LC

02	PRODUCT TYPE
-	Compact Encloser Type Limit Switch

03	QUANTITY OF
1	1 Switch
2	2 Switch

05	ENCLOSURE MATERIAL
-	ALU + PLASTIC

06	QUANTITY OF
-	3 Entries

07	CABLE ENTRY
-	M20x1.5
B	1/2" NPT

04	SWITCH TYPE			
R1	Honeywell	V15S05-CZ100A05-01	SPDT	5 A ,125 Or 250 VAC, 100mA, 48 VDC (NO/NC), 30 mA, 250 VDC (NO/NC)
R2	Honeywell	V7-1C17E9-201	SPDT	15 A,125 Or 250 VAC ,500 mA 125 VDC, (NO/NC) mA 250 VDC (NO/NC)
W1	Honeywell	V15S05-CZ100A05-01	DPDT	5 A ,125 Or 250 VAC 100mA, 48 VDC (NO/NC), 30 mA, 250 VDC (NO/NC)
W2	Honeywell	V7-1C17E9-201	DPDT	15 A ,125 Or 250 VAC 500mA, 125 VDC, 250 mA,250 VDC (NO/NC)

08	TEMP. RANGE
-	General (-20°C to +80°C)
D	Cold Temp. (-40 to +80°C) (W2)

09	VISUAL
-	Red & Yellow
G	Red & Green

10	APPROVALS
-	No Approval
E	CE

11	CONFIGURATION
-	REGULAR
C1	CONFIG 1
C2	CONFIG 2
C3	CONFIG 3
⋮	⋮
C9	CONFIG 9
CA	CONFIG 10
CB	CONFIG 11

12	VERSION
-	VERSION 0
V1	VERSION 1
V2	VERSION 2
V3	VERSION 3
⋮	⋮
V9	VERSION 9
VA	VERSION 10
VB	VERSION 11

LC-2R1
COMPACT ENCLOSURE TYPE LIMIT SWITCH SPDT 2 SWITCH
3 ENTRIES M20 X 1.5 (-20 to +80°C) RED & YELLOW

Note : The above chart is for identification purposes only, and it may not be possible to make all combinations for the above chart.

LS - SERIES LIMIT SWITCH MODEL IDENTIFICATION CHART

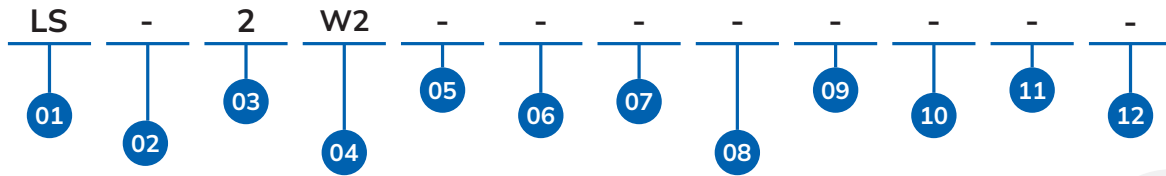

01	SERIES
-	LS

02	PRODUCT TYPE
-	Standard Encloser Type Limit Switch

03	QUANTITY OF
1	1 Switch
2	2 Switch
4	4 Switch

05	ENCLOSURE MATERIAL
-	Diecast Aluminium

06	QUANTITY OF
-	2 Entries

07	CABLE ENTRY
-	M20x1.5
B	1/2" NPT
C	3/4" NPT

08	TEMP. RANGE
-	General (-20°C to +80°C)
D	Cold Temp. (-40°C to +80°C) (F2,R2,& W2)
H	High Temp. (-20°C to +100°C) (A1,D1,F1,& F2)

04	SWITCH TYPE			
R1	Honeywell	V15S05-CZ100A05-01	SPDT	5 A ,125 Or 250 VAC, 100mA, 48 VDC (NO/NC), 30 mA, 250 VDC (NO/NC)
R2	Honeywell	V7-1C17E9-201	SPDT	15 A,125 Or 250 VAC ,500 mA 125 VDC, (NO/NC) mA 250 VDC (NO/NC)
W1	Honeywell	V15S05-CZ100A05-01	DPDT	5 A ,125 Or 250 VAC 100mA, 48 VDC (NO/NC), 30 mA, 250 VDC (NO/NC)
W2	Honeywell	V7-1C17E9-201	DPDT	15 A ,125 Or 250 VAC 500mA, 125 VDC, 250 mA,250 VDC (NO/NC)
D1	P & F	NJ2-V3-N	FLAT	8V DC, 3mA ,NC
D2	P & F	NBB3-V3-Z4	FLAT	10-60V DC, 100mA, NO
F1	P & F	SJ3.5-N	SLOT	8V DC, >3 mA ; <1 mA (NC)
F2	P & F	SJ3.5-SN	SLOT	8V DC, >3 mA ; <1 mA (NC)
B1	P & F	NJ2-V3-N	Flat Limit Switch Having Total 4 Sensors 2 Open & 2 Close	8V DC, 3mA ,NC
A1	P & F	NJ2-12GM-N	Cylindrical	-
A2	P & F	NBN4-12GM40-Z0	Cylindrical	-

09	VISUAL
-	Red & Yellow

10	APPROVALS
-	No Approval
T	ATEX / IECEx Ex d
P	PESO
S	BIS
L	IP67
E	CE

11	CONFIGURATION
-	REGULAR
C1	CONFIG 1
C2	CONFIG 2
C3	CONFIG 3
...	...
C9	CONFIG 9
CA	CONFIG 10
CB	CONFIG 11

12	VERSION
-	VERSION 0
V1	VERSION 1
V2	VERSION 2
V3	VERSION 3
...	...
V9	VERSION 9
VA	VERSION 10
VB	VERSION 11

LS-2W2
STANDARD ENCLOSURE TYPE LIMIT SWITCH DPDT 2 SWITCH 2 ENTRIES
M20 X 1.5 (-20 to +80°C) RED & YELLOW

Note : The above chart is for identification purposes only, and it may not be possible to make all combinations for the above chart.



**ROTO SEAL COUPLING
SERIES**

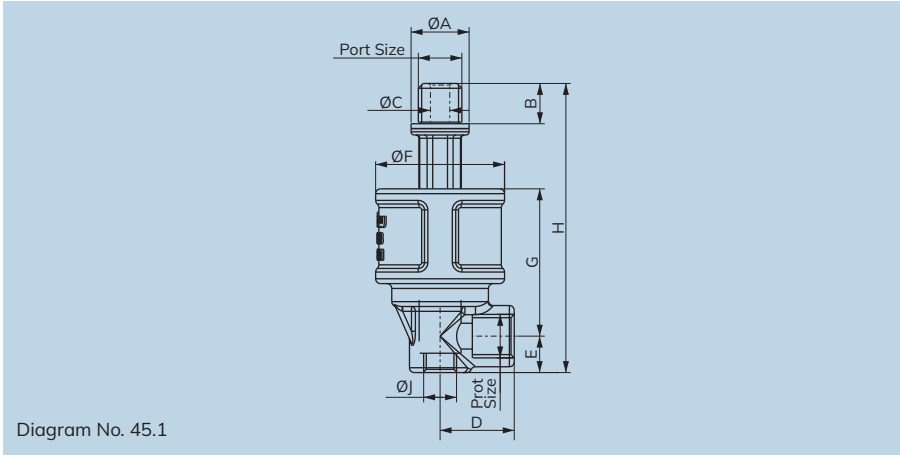

Specifications

Port :	1/4", 3/8", 1/2", 3/4", 1", 1 1/4", 1 1/2" & 2" (Available BSP / NPT)
Media :	Air, Water, Oil & Gas
Pressure :	Upto 10 bar
Temperature :	Viton (FKM) -10°C to 180°C
RPM :	1000 RPM

Section View



Features

- High-Performance Bearings & Seals.
- Dual Connection Available.

Technical Data (All dimensions in mm)

All Dimensions are approx.

Model No.	Diagram No.	Body Material	Port Size	Seal Material	A	B	C	D	E	F	G	H	J
UCV-1L / UCV-1R	45.1	CF8 / CF8M	1/4"	VITON	18	14	6	23	12	40	45	90	1/8"
UCV-7L / UCV-7R	45.1	CF8 / CF8M	3/8"	VITON	22	14	10	23	13	48	53	99	1/4"
UCV-2L / UCV-2R	45.1	CF8 / CF8M	1/2"	VITON	26	16	12	28	17	56	61	106	3/8"
UCV-3L / UCV-3R	45.1	CF8 / CF8M	3/4"	VITON	32	19	19	40	21	72	72	145	1/2"
UCV-4L / UCV-4R	45.1	CF8 / CF8M	1"	VITON	39	25	24	44	28	83	84	171	3/4"
UCV-5L / UCV-5R	45.1	CF8 / CF8M	1 1/4"	VITON	48	27	32	49	32	95	98	193	1"
UCV-6L / UCV-6R	45.1	CF8 / CF8M	1 1/2"	VITON	54	27	36	48	32	95	98	193	1 1/4"
UCV-8L / UCV-8R	45.1	CF8 / CF8M	2"	VITON	68	32	47	62	40	123	124	269	1 1/2"

UCV-SERIES ROTO SEAL COUPLING MODEL CHART

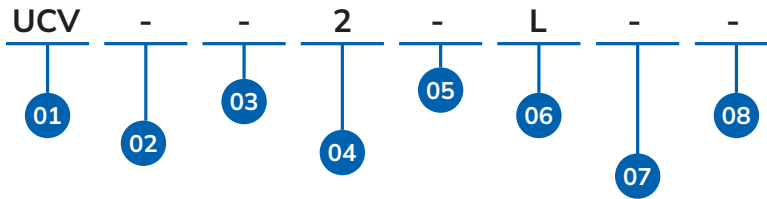

01	SERIES
UCV	

02	PRODUCT TYPE
-	Roto Seal Coupling

03	BODY MATERIAL
-	CF8
M	CF8M
W	WCB

04	PORT SIZE
1	1/4"
2	1/2"
3	3/4"
4	1"
5	1-1/4"
6	1-1/2"
7	3/8"
8	2"

05	PORT CONNECTION
-	BSP
N	NPT

06	THREAD TYPE
L	LHS THREAD
R	RHS THREAD

07	CONFIGURATION
-	REGULAR
C1	CONFIG 1
C2	CONFIG 2
C3	CONFIG 3
⋮	⋮
C9	CONFIG 9
CA	CONFIG 10
CB	CONFIG 11

08	VERSION
-	VERSION 0
V1	VERSION 1
V2	VERSION 2
V3	VERSION 3
⋮	⋮
V9	VERSION 9
VA	VERSION 10
VB	VERSION 11

UCV-2L
1/2" ROTO SEAL COUPLING CF8-VITON+CFT-BSP-LHS THREAD

Note: The above chart is for identification purposes only, and it may not be possible to make all combinations for the above chart.



IRRIGATION SERIES

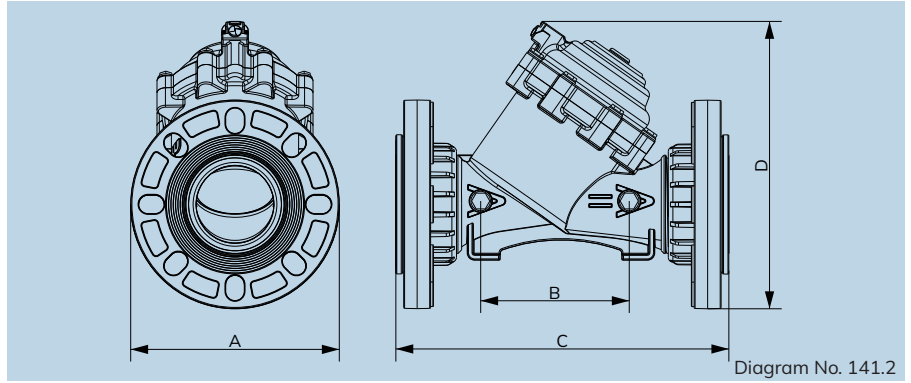
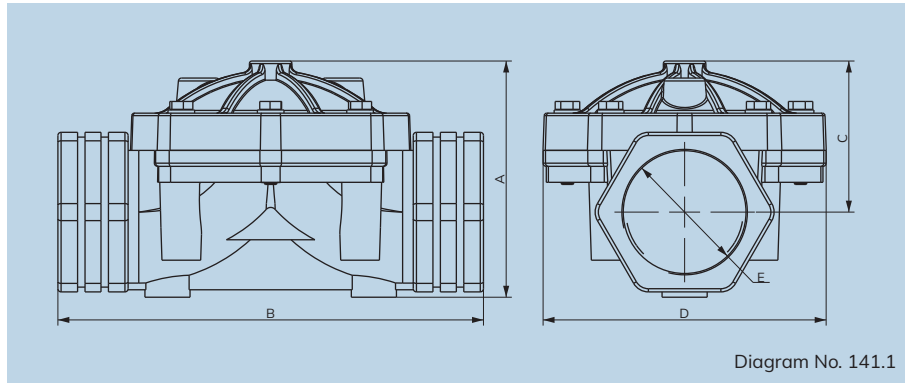

Specifications

Port Size	1½", 2", 2½", 3" & 4" (Available BSP / NPT / BSPT)
Body Material :	Nylon GF
Diaphragm :	Natural Rubber
Max Media Temp :	60°C
Min to Max Pulse width :	50 to 100 ms
Circumstance Temp :	-10°C to 60°C
Media :	Water
Main Features :	Internal Parts are in superior corrosion resistance steel, Suitable for irrigation, 2 Position Mor & 3 Position Mor
Operating Voltage :	Non Latching : 12V DC, 24V DC, 24V AC, 230V AC, Latching : 12V DC, 24V DC, 9 to 30V DC

Pressure Drop Curve

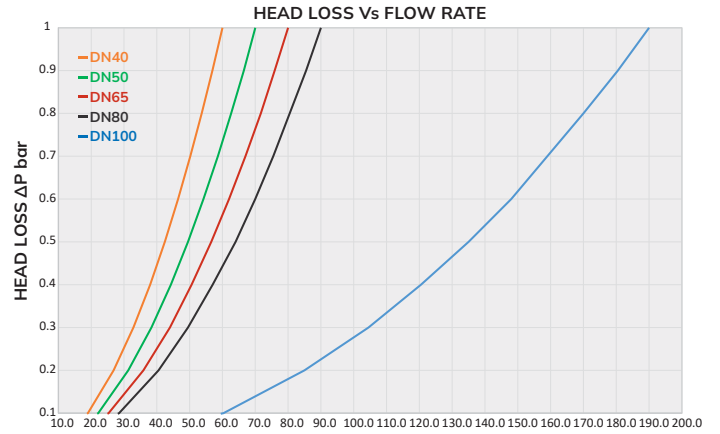

Technical Data

Model No.	Body Material	Pipe (Inch)	Min. Operating Pressure Kg/cm ²	Max. Operating Pressure Kg/cm ²	Seal & Diaphragm Material	Flow Factor Kv m ³ / hr
ENN-6C	Nylon GF	1½"	1	10	Natural Rubber	60
ENN-8CV1	Nylon GF	2"	1	10	Natural Rubber	70
ENN-9C	Nylon GF	2½"	1	10	Natural Rubber	80
ENN-AC	Nylon GF	3"	1	10	Natural Rubber	90
ENN-BC	Nylon GF	4"	1	10	Natural Rubber	190

Dimension (All dimensions in mm)

Model No.	Diagram No.	A	B	C	D	E
ENN-6C	141.1	111	200	71	133	1½"
ENN-8CV1	141.1	111	200	71	133	2"
ENN-9C	141.1	138	250	87	160	2½"
ENN-AC	141.1	138	250	87	160	3"
ENN-BC	141.2	316	352	203	Ø225	4"

ENN - SERIES EXTERNAL PILOT OPERATED DIAPHRAGM PLASTIC VALVE MODEL CHART

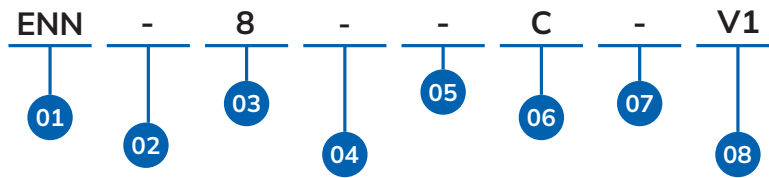

01	SERIES
ENN	ENN

02	PRODUCT TYPE
-	Regular
C	2 Way Control
D	Pressure Reducing
L	Pressure Reducing/ Pressure Sustaining With Solenoid
F	Quick Pressure Relief Valve
G	Pressure Reducing With Relief Solenoid Valve
H	Pressure Reducing With Relief Valve
J	With Solenoid On-off Valve 2 Position Mor
K	With Solenoid On-off Valve 3 Position Mor
P	Pressure Reducing With Solenoid Valve
Q	Quick Pressure Relief With Solenoid Valve
R	Pressure Reducing Pressure Sustaining
S	Pressure Sustaining
T	Pressure Sustaining With Solenoid Valve

03	PORT SIZE
6	1 1/2"
8	2"
9	2 1/2"
A	3"
B	4" Reducer Bore

04	PRESSURE RANGE
-	1 To 10 Bar
49	1 To 5 Bar

05	CONNECTION
-	BSPT
B	BSP
N	NPT

06	VALVE POSITION
-	Blank
C	NC
Z	NO

07	CONFIGURATION
-	Regular
C1	CONFIG 1
C2	CONFIG 2
C3	CONFIG 3
⋮	⋮
C9	CONFIG 9
CA	CONFIG 10
CB	CONFIG 11

08	VERSION
-	VERSION 0
V1	VERSION 1
V2	VERSION 2
V3	VERSION 3
⋮	⋮
V9	VERSION 9
VA	VERSION 10
VB	VERSION 11

ENN-8CV1
2" EXTERNAL PILOT OPERATED NYLON GF-NATURAL
RUBBER-1 TO 10 Bar-BSPT-NC-VERSION 1

Note: The above chart is for identification purposes only, and it may not be possible to make all combinations for the above chart.

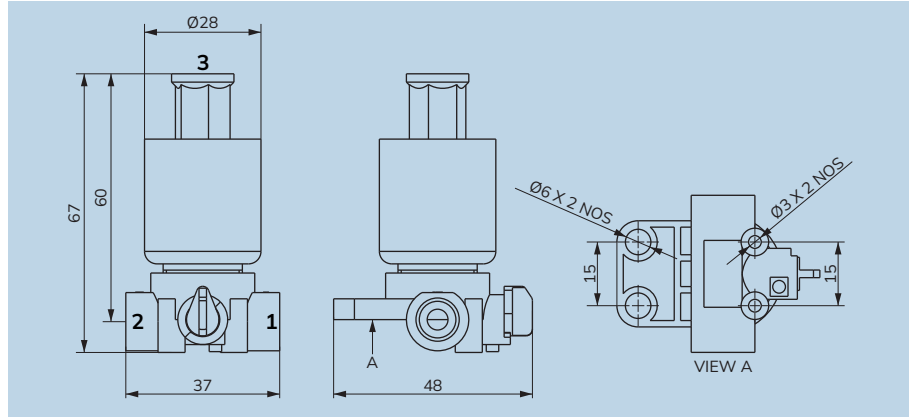

2 Way - 3 Way Valve Specifications

Port :	Refer below technical data sheet (Available BSPT / NPT)		
End Connection :	Screwed		
Body Material :	Nylon GF		
Seal & 'O'Ring :	Nitrile (NBR)		
Max Media Temp :	5°C to 50°C		
Circumstance Temp :	-10°C to 50°C		
Media :	Water		
Main Features :	Internal Parts are in superior corrosion resistance steel, (Equivalent to SS316L) Suitable for irrigation.		
Operating Voltage :	24AC	12DC	24DC - Latching
Power Consumption :	8W	3W	8W - Latch, 3W - Delatch

Technical Data

Model No.	Valve Type	Body Material	Pipe (Inch)	Orifice(mm)	Min. Operating Pressure Kg/cm ²	Max. Operating Pressure Kg/cm ²	Seal & Diaphragm Material	Flow Factor Kv m ³ / hr
DAP-DNC016	2 Way	Nylon GF	1/8"	1.6	0	10	NITRILE (NBR)	0.07
DAP-TC012	3 Way	Nylon GF	1/8"	1.2	0	10	NITRILE (NBR)	0.042
DAP-T03012	3 Way	Nylon GF	1/8"	1.2	0	10	NITRILE (NBR)	0.042

Pipe Connection

Valve Position	Valve Type	Port No. - 1	Port No. - 2	Port No. - 3
Normally Close	3 Way	Input	Output	Exhaust
Normally Open	3 Way	Exhaust	Output	Input
Normally Close	2 Way	Output	Input	-

DAP - SERIES DIRECT ACTING SOLENOID PLASTIC VALVE MODEL CHART

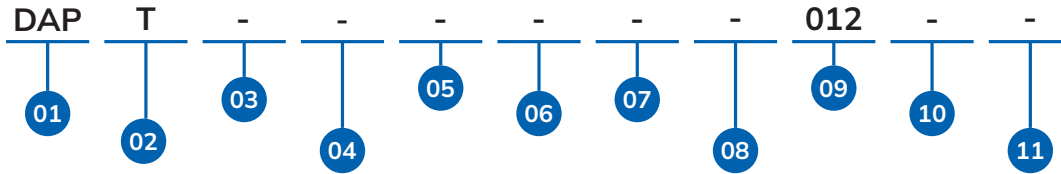

01	SERIES
	DAP

02	PRODUCT TYPE
D	2 Way
T	3 Way

03	PORT SIZE
-	1/8"

04	PRESSURE RANGE
-	0 - 10 Bar
03	0 - 7 Bar
05	0 - 16 Bar
19	0 - 5 Bar

05	PORT CONNECTION
-	BSPT
P	NPT
B	BSP

06	VALVE POSITION
-	NO
N	NC

07	COIL DIA
-	12MM
C	10MM

08	FEATURES
-	Turn Mor
3	3 Position Mor
W	W/O Mor

09	ORIFICE IN MM
012	1.2 MM
016	1.6 MM

10	CONFIGURATION
-	Regular
C1	CONFIG 1
C2	CONFIG 2
C3	CONFIG 3
⋮	⋮
C9	CONFIG 9
CA	CONFIG 10
CB	CONFIG 11

11	VERSION
-	VERSION 0
V1	VERSION 1
V2	VERSION 2
V3	VERSION 3
⋮	⋮
V9	VERSION 9
VA	VERSION 10
VB	VERSION 11

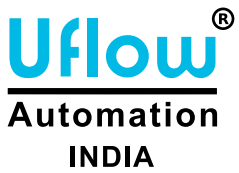

DAP-T012
 1/8" 3 WAY DIRECT ACTING NYLON GF-NITRILE-0 TO 10 Bar
 -BSPT-NO-12MM-TURN MOR-1.2MM ORIFICE

Note : The above chart is for identification purposes only, and it may not be possible to make all combinations for the above chart.

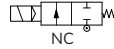
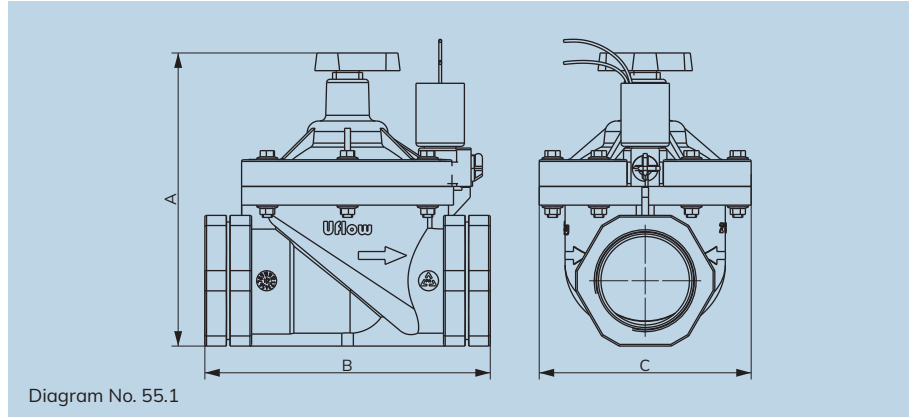

Specifications

Port :	¾", 1", 1½" & 2" (Available in BSP / BSPT / NPT)		
End Connection :	Screwed		
Body Material :	Nylon GF		
Diaphragm :	Natural Rubber		
Max Media Temp :	5°C to 50°C		
Ambient Temp :	-10°C to 50°C		
Media :	Water		
Operating Voltage :	24AC	24DC	12DC
Power Consumption :	8W	8W	8W
Coil Features :	High Reliability Unaffected by Voltage Surges. Easy coil changes coil lockable in 4X90 position or freely movable in between as require.		
Coil Housing :	IP65 Epoxy square coil, IP65 Metallic round enclosure, IP68 Weatherproof enclosure.		
Other Specification Data :	Available on Request		

NOTE: Use of filter in the inlet port is recommended.

Feature

- Inbuilt Flow Control Capabilities.
- Manual Override in All The Valve.
- Pressure Below Seat to Reduce Water Hummer.
- Low Head Loss With High Flow.

Technical Data

Model No.	Body Material	Pipe (Inch)	Orifice (mm)	Min. Operating Pressure mbar	Max. Operating Pressure bar	Seal & Diaphragm Material	Flow Factor Kv m³ / hr
PNN-3TM	Nylon GF	¾"	20	0.5	10	Natural Rubber	8
PNN-4TM	Nylon GF	1"	25	0.5	10	Natural Rubber	12
PNN-6TM	Nylon GF	1½"	40	0.5	10	Natural Rubber	23
PNN-8TM	Nylon GF	2"	52	0.5	10	Natural Rubber	38

Dimension (All dimensions are in mm)

All Dimensions are approx.

Model No.	Port Size	Diagram No.	A	B	C
PNN-3TM	¾"	55.1	108	110	81
PNN-4TM	1"	55.1	114	110	81
PNN-6TM	1½"	55.1	180	160	126
PNN-8TM	2"	55.1	190	170	126

Section View



PNN - SERIES PILOT OPERATED DIAPHRAGM TYPE PLASTIC VALVE MODEL CHART

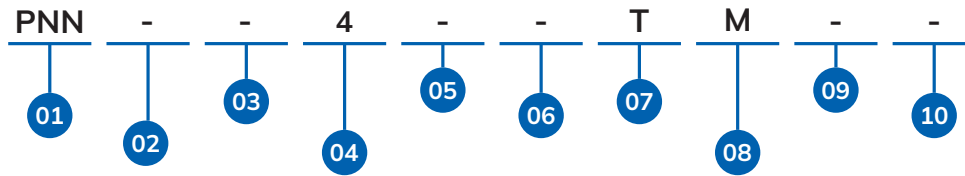

01	SERIES
	PNN

02	PRODUCT TYPE
-	Pilot Operated Diaphragm
D	External Pilot Operated Diaphragm Valve

03	SEAL MATERIAL
-	Natural Rubber
E	EPDM

04	PORT SIZE
3	3/4"
4	1"
6	1-1/2"
8	2"

05	PRESSURE RANGE
-	0.5 - 10 Bar

06	PORT CONNECTION
-	BSP
N	NPT
P	BSPT

07	COIL DIA
E	14MM AC
F	14MM DC
T	12MM AC
U	12MM DC

08	FEATURES
-	W/O Flow Control
M	MOR With Flow Control

09	CONFIGURATION
-	Regular
C1	CONFIG 1
C2	CONFIG 2
C3	CONFIG 3
⋮	⋮
C9	CONFIG 9
CA	CONFIG 10
CB	CONFIG 11

10	VERSION
-	VERSION 0
V1	VERSION 1
V2	VERSION 2
V3	VERSION 3
⋮	⋮
V9	VERSION 9
VA	VERSION 10
VB	VERSION 11

PNN-4TM
1" PILOT OPERATED DIAPHRAGM NYLON GF-NATURAL RUBBER-0.5 TO 10 BAR
-BSP-NC-12MM AC-MOR WITH FLOW CONTROL

Note : The above chart is for identification purposes only, and it may not be possible to make all combinations for the above chart.



MEDICAL VALVES & REGULATOR SERIES

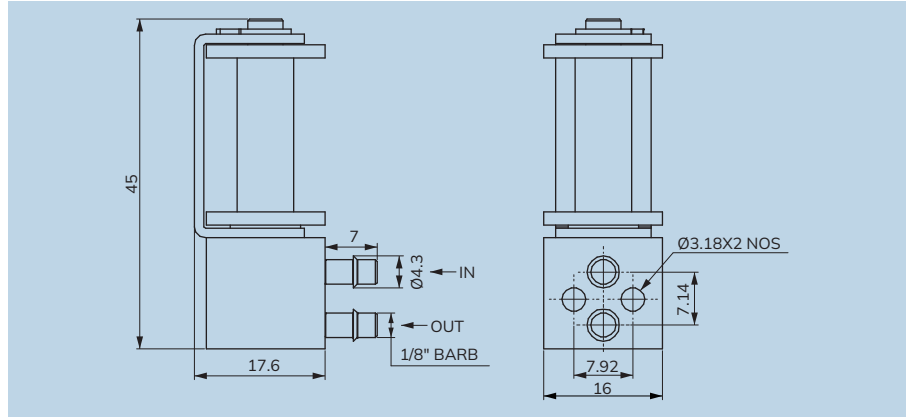

Specifications

Valve Type:	2 Way Normally Closed Proportional Valve
Port:	1/8" BARB, Manifold Mounting
Body Material:	Brass
Seal:	NBR Optional FKM, Viton
Media:	Air, Oxygen, Nitrous Oxide, Carbon Dioxide, Heliox & Other Medical Gases
Main Features :	Flow adjustment, Opening time adjustment, Quick release initial flow adjustment
LPM:	6LPM @ 10PSI Differential Pressure
Operating Environment:	32°F to 132°F (0°C to 55°C)
Storage Temperature:	-40°F to 158°F (-40°C to 70°C)
Dimensions:	L-17.6mm, W-16mm, H-45mm
Weight:	58g
Power:	9V DC (2 Watts)
Electric Termination:	15" Lead Wire
Stem Base:	Stainless steel
All Others:	NBR/FKM, Stainless Steel, Aluminium(Manifold)

Features

- Low power consumption generates less heat
- Proven performance tested to 100 million life cycles
- Uses either DC current or pulse width modulation with closed loop feedback to deliver optimal system performance.

Applications

- Ventilators
- Anesthesia Delivery & Monitors
- Insufflators
- Pressure and Flow Control

Performance Characteristics

Leak Rate:	<0.2 sccm of helium (bubble tight)
Hysteresis:	25% of full scale current (Max)
Response time:	10ms Typical
Reliability:	100 Million Cycles, 0.95 Reliability Factor, 95% Confidence Interval

NOTE: Contact for customized configuration: eg custom calibration and electrical connections.

PVL- SERIES PROPORTIONAL (LOW) FLOW CONTROL SOLENOID VALVE MODEL CHART

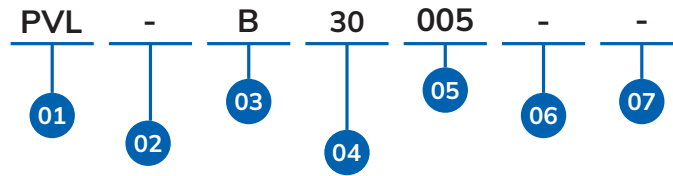

01	SERIES
	PVL

02	PRODUCT TYPE
-	Proportional Valve

03	PORT SIZE
M	Manifold Mounted
B	1/8" Barb

04	PRESSURE RANGE
30	30 PSI
10	10 PSI

05	LPM
008	8 LPM
015	15 LPM
005	5 LPM
001	1 LPM

06	CONFIGURATION
-	Regular
C1	CONFIG 1
C2	CONFIG 2
C3	CONFIG 3
⋮	⋮
C9	CONFIG 9
CA	CONFIG 10
CB	CONFIG 11

07	VERSION
-	VERSION 0
V1	VERSION 1
V2	VERSION 2
V3	VERSION 3
⋮	⋮
V9	VERSION 9
VA	VERSION 10
VB	VERSION 11

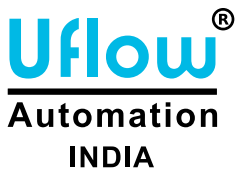

PVL-B30005
1/8" BARB PROPORTIONAL VALVE BRASS-VITON-30 PSI-5 LPM

Note : The above chart is for identification purposes only, and it may not be possible to make all combinations for the above chart.

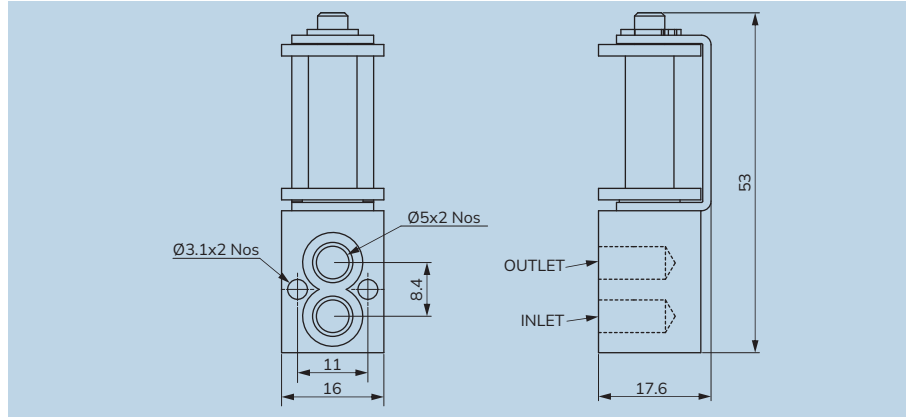

Specifications

Valve Type:	2 Way Normally Closed Proportional Valve
Port:	Manifold Mounting
Body Material:	Brass
Seal:	Silicon
Media:	Air, Oxygen, Nitrous Oxide, Carbon Dioxide, Heliox & Other Medical Gases
LPM:	150LPM @ 35PSI Differential Pressure
Operating Environment:	32 °F to 132 °F (0 °C to 55 °C)
Storage Temperature:	-40 °F to 158 °F (-40 °C to 70 °C)
Dimensions:	L-17.6mm, W-16mm, H-53mm
Weight:	56g
Power:	12V DC (2.5 Watts)
Electric Termination:	15" Lead Wire
Stem Base:	Stainless steel
All Others:	Silicon, VITON, Stainless Steel, Aluminium(Manifold)

Features

- Low power consumption generates less heat
- Proven performance tested to 100 million life cycles
- Uses either DC current or pulse width modulation with closed loop feedback to deliver optimal system performance.

Applications

- Ventilators
- Anesthesia Delivery & Monitors
- Insufflators
- Pressure and Flow Control

Performance Characteristics

Leak Rate:	The leakage shall not exceed the following values: Internal: 5.0 sccm of Air up to 101 psi (7 bar) External: 0.5 sccm of Air up to 101 psi (7 bar)
Hysteresis:	25% of full scale current (Max)
Response time:	10ms Typical
Reliability:	100 Million Cycles, 0.95 Reliability Factor, 95% Confidence Interval

NOTE: Contact for customized configuration: eg custom calibration and electrical connections.

Manifold Dimensions

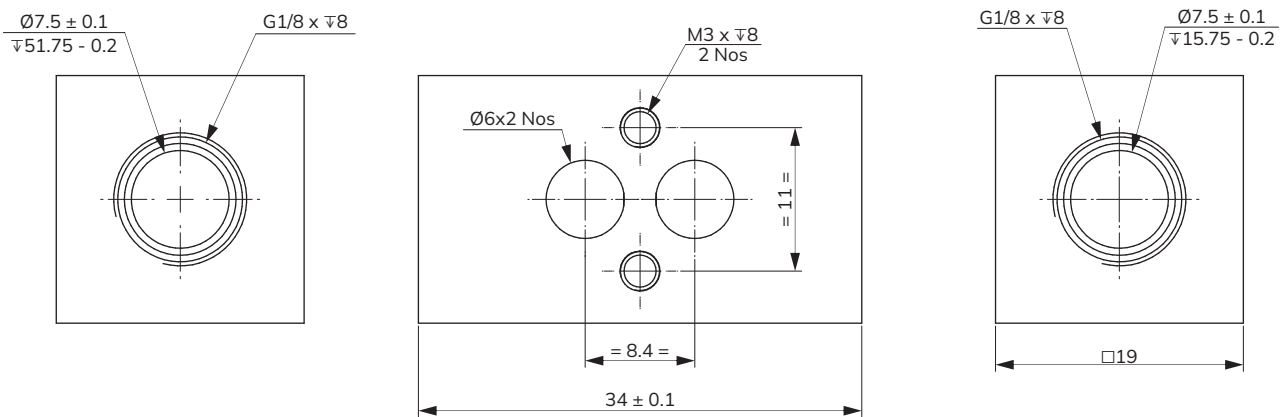

NOTE: In order to provide the best possible solution for your application, please provide the following requirements when contacting Applications Engineering:

- Media, Inlet & Outlet Pressures
- System Supply Voltage
- Minimum Required Flow Rate
- Media & Ambient Temperature Range

PVH- SERIES PROPORTIONAL (HIGH) FLOW CONTROL SOLENOID VALVE MODEL CHART

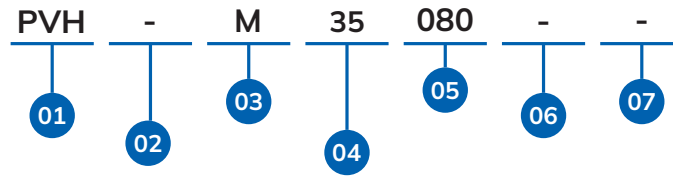

01	SERIES
	PVH

02	PRODUCT TYPE
-	Proportional Valve

03	PORT SIZE
M	Manifold Mounted
B	1/8" Barb

04	PRESSURE RANGE
45	45 PSI
35	35 PSI
60	60 PSI
30	30 PSI

05	LPM
150	150 LPM
080	080 LPM

06	CONFIGURATION
-	Regular
C1	CONFIG 1
C2	CONFIG 2
C3	CONFIG 3
⋮	⋮
C9	CONFIG 9
CA	CONFIG 10
CB	CONFIG 11

07	VERSION
-	VERSION 0
V1	VERSION 1
V2	VERSION 2
V3	VERSION 3
⋮	⋮
V9	VERSION 9
VA	VERSION 10
VB	VERSION 11

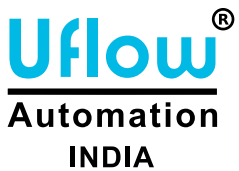

PVH-M35080
 MANIFOLD MOUNTED PROPORTIONAL VALVE BRASS-VITON-
 35 PSI-80 LPM

Note : The above chart is for identification purposes only, and it may not be possible to make all combinations for the above chart.

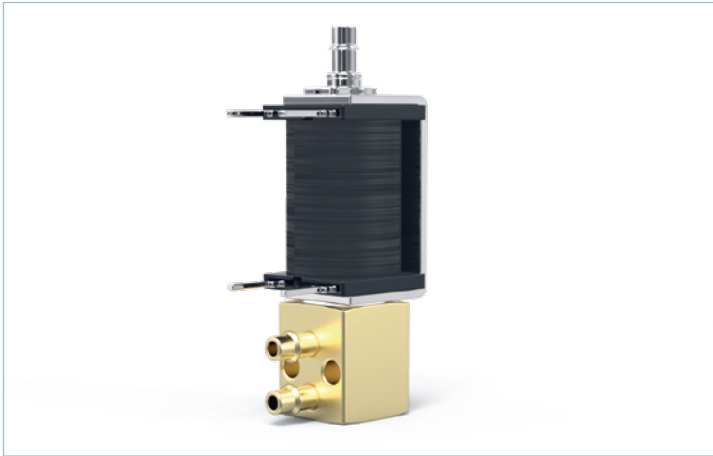

Specifications

Port :	1/8" - Barb
Seal Matrial :	Nitrile (NBR)
Media Temp :	-30°C to 90°C
Operating Voltage :	5V DC
Power Consumption :	0.5 W
Media :	Air, Gas
Main Features :	Internal Parts are in superior corrosion resistance steel, (Equivalent to ss316L) Suitable for Food Industries, Pharmaceuticals, Chemical application & Highly Corrosive Environment.

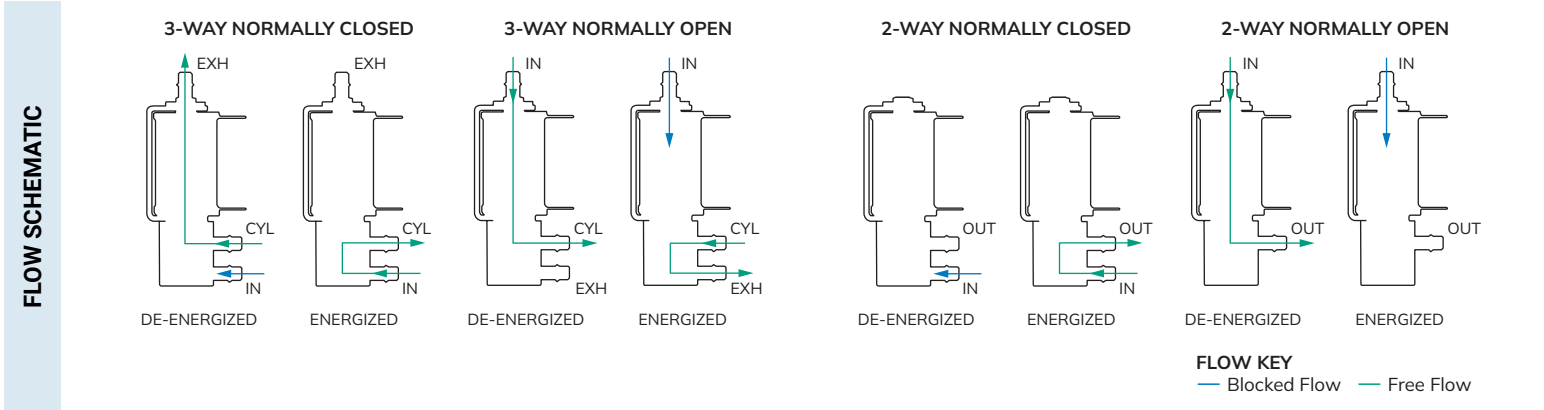

Features

- Design for extreme low wattage condition with a compact size.
- High speed response time.
- Reliable operation over 200 million cycles.
- Lubrication not essential

Applications

- Medical and Therapeutic Healthcare
- Clinical Chemistry and Analysis Equipment
- Drop-on-Demand Printing
- Environmental Instrumentation

Technical Data

Valve Model No.	Coil Model No.	Body Material	Pipe (Inch)	Orifice (mm)	Min. Operating Pressure PSI	Max. Operating Pressure PSI	Seal Material	Flow Factor Cv
UMV-T013	R4E0AB	Brass	1/8" - Barb	1.3	0	10	Nitrile (NBR)	0.038

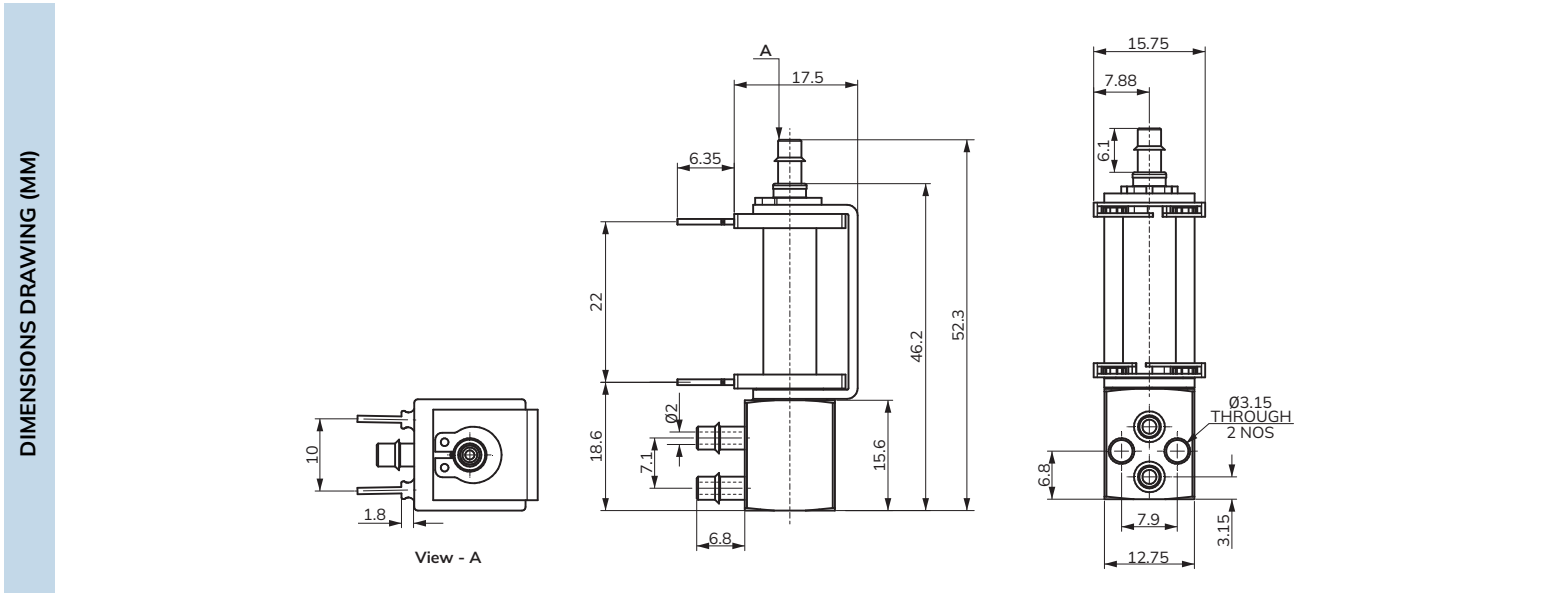

* All dimensions are approx

UMV - SERIES MINIATURE DIRECT ACTING SOLENOID VALVE MODEL CHART

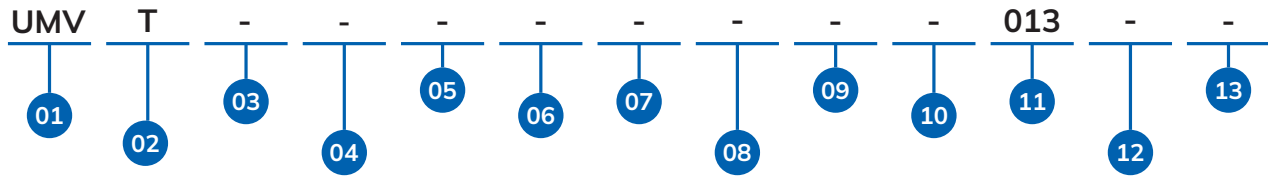

01	SERIES
	UMV

02	PRODUCT TYPE
D	2 Way
T	3 Way

03	BODY MATERIAL
-	Brass Bar

04	SEAL MATERIAL
-	Nitrile
V	Viton

05	PORT SIZE
-	1/8"

06	PRESSURE RANGE
-	0 to 10 PSI

07	PORT CONNECTION
-	Barb

08	VALVE POSITION
-	Universal

09	COIL DIA
-	5.5MM DC

10	FEATURES
-	Blank

11	ORIFICE IN MM
013	1.3 MM

12	CONFIGURATION
-	Regular
C1	CONFIG 1
C2	CONFIG 2
C3	CONFIG 3
⋮	⋮
C9	CONFIG 9
CA	CONFIG 10
CB	CONFIG 11

13	VERSION
-	VERSION 0
V1	VERSION 1
V2	VERSION 2
V3	VERSION 3
⋮	⋮
V9	VERSION 9
VA	VERSION 10
VB	VERSION 11

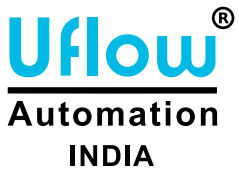

UMV-T013
1/8" 3 WAY DIRECT ACTING BRASS BAR-NITRILE-0 TO 10 PSI-BARB-NO-5.5MM DC-1.3MM ORIFICE

Note : The above chart is for identification purposes only, and it may not be possible to make all combinations for the above chart.

Scribble Note....

A series of horizontal dashed lines for writing, spaced evenly down the page.

Our Clients



Global Presence...



Made In India



CONTACT US:

For Domestic Inquiry

✉ sales@uflowvalve.com 📞 +91 85110 98822 🌐 www.uflowvalve.com

For Export Inquiry

✉ export@uflowvalve.com 📞 +91 99744 77370 📞 +91 78018 09550

📍 Uflow Automation, Ankur Industrial Complex, Survey No: 275/276, Plot No: 31, Nr. Intol Cast Pvt. Ltd. Shapar(Veraval) Dist.: Gujarat (India) - 360 024.