

# COMPREHENSIVE RANGE OF SOFT SEATED BALL VALVE

Simplified, Standardized & Sustainable Solutions

IPC is an expert solution provider for High Performance Industrial Valves & Valve Automation Systems. In the last 20 years IPC has worked with many reputed companies in India and Overseas.

Safety

Performance

Cost-Effectiveness

Reliability

Refineries, Fertilizers, Petro-chemicals, Pharma, Food many other industries





# SOFT SEATED FLOATING BALL VALVE

Floating ball valves come in two and three piece design. Available in standard as well as customized configurations. These ball valves are ideal for economical automation. Floating ball valves are easy to install and maintain, combine superior performance and fast maintenance.

Floating ball valves are widely used across many industries and are considered as one of the most trusted valves.

The ball in the floating ball valve is not connected to any component. When the valve is closed, the media is pressed from one end (upstream) of the valve, the ball can produce a certain displacement and tightly seal on the sealing surface of the outlet end (downstream) of the valve, thus producing an outlet seal.

- Low torque design of ball valves makes them very easy to operate without any efforts
- Sturdy Construction, easy to assemble and Install
- MOC - CS, SS304, SS316, SS316L and Alloy Steel #150, #300, #400, #600, #800

## QUICK RESPONSE, EFFICIENT DELIVERY AND QUALITY PRODUCTS!



Integral Process Controls was founded in 2001 with an objective to solve two key pain points for the customers. First, was to reduce the valve delivery time significantly to meet the aggressive demand timelines of the clients. Secondly, we sensed a need to meet the huge and largely unmet need for assured supply of quality valve and valve automation solutions of the customers. We set out to serve this very gap.

### WHY US



#### QUALITY

Highest benchmark and an uncompromising attitude



#### EXPERTISE

Extensive experience and an 'ownership' approach



#### SOLUTIONING

Simplified, Standardized, Sustainable

## RANGE OF SOFT SEATED BALL VALVE

IPC Manufactures comprehensive range of soft seated floating ball valves including 2 piece and 3 piece valves conforming to various pressure classes. We provide lever as well as automated soft seated ball valves.

TYPE	END CONNECTION	PORT	ASME CLASS	SIZE									
				1/2"	3/4"	1"	1-1/2"	2"	2-1/2"	3"	4"	6"	8"
TWO PIECE	FLANGED	FULL	150 / 300	✓	✓	✓	✓	✓	✓	✓	✓	✓	✓
		FULL	600	✓	✓	✓	✓	✓		✓	✓		
THREE PIECE	SOCKET WELD / SCREWED	FULL	400 / 800	✓	✓	✓	✓	✓					

### APPLICABLE STANDARDS

- FACE TO FACE - ASME B 16.10
- FLANGE DIMENSIONS - ASME B 16.5
- BUTT WELDED VALVE ENDS - ASME B 16.25
- PRESSURE TESTS - API 598
- FIRE SAFETY - API 607

### DESIGN & TESTING STANDARDS

- IPC valves are designed and manufactured as per ASME. B 16.34. These standards cover Pressure - Temperature ratings, minimum shell thickness, bore diameter for each size & class.
- Castings inspection as per MSS-SP 55
- Actuator mounting pad on the valve is as per ISO 5211

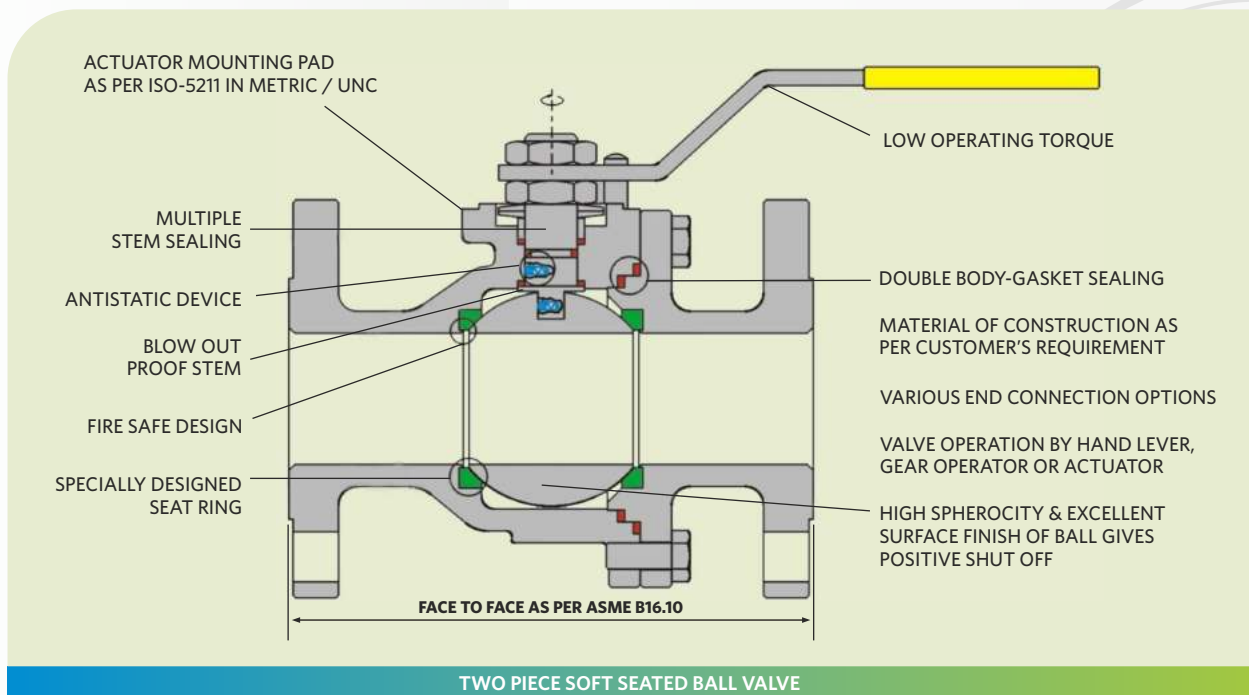



## DESIGN FEATURES

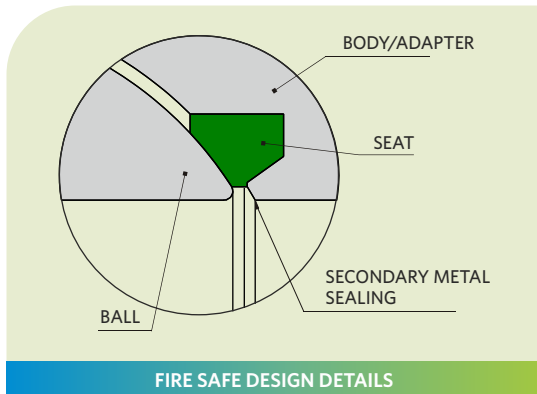

FIRE SAFE DESIGN DETAILS

- Fire safe design

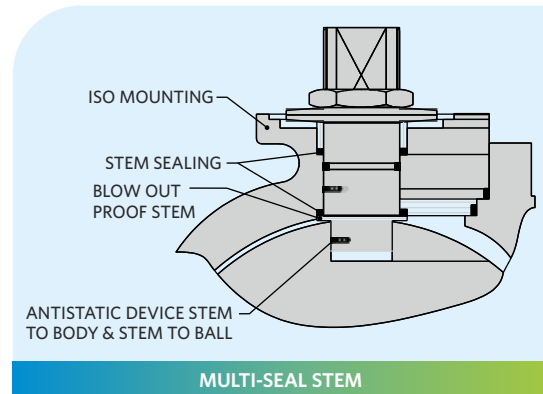

MULTI-SEAL STEM

- Antistatic devices are built in the valve stem to ensure electrical continuity between ball, stem and body. Thus, providing greater safety while handling volatile media. Higher size ball valves are designed with stem bearing to absorb radial loading on the stem.
- Multiple stem sealing ensures high degree of sealing.

*Note: For sizes up to 1½" one Antistatic device is provided*

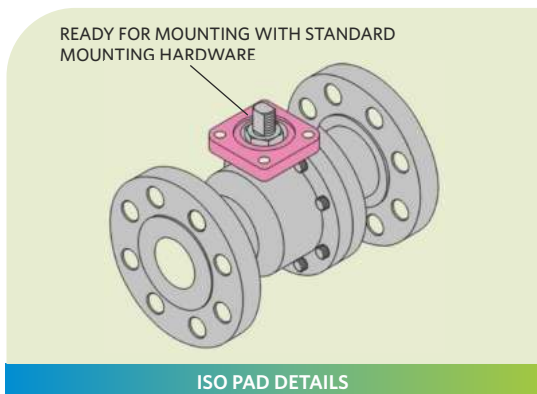

ISO PAD DETAILS

- IPC valves incorporate ISO - 5211 top pad which simplifies actuator / gear operator mounting

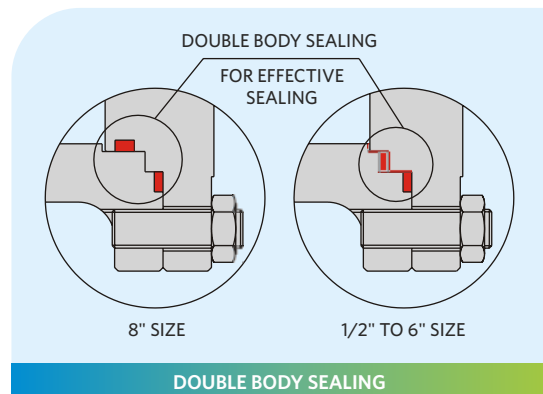

DOUBLE BODY SEALING

- Double body gasket ensures positive body - joint sealing against pipeline stresses

### CORROSION PROTECTION AND PAINTING

All castings are shot blasted and are subjected to dewatering oil coats.

Prior to painting, valves are thoroughly cleaned

and primer coated with inorganic Zinc Silicate. An intermediate coat of Epoxy Polyamide followed by final coat of Polyurethane Aliphatic paint is applied in semi-gloss finish.

## PRESSURE - TEMPERATURE RATINGS

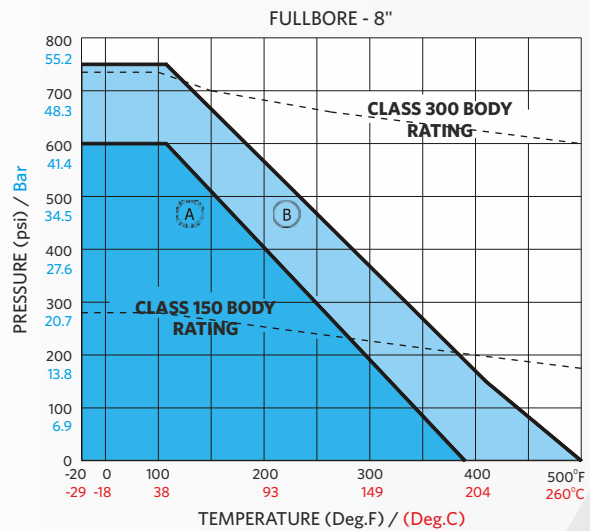
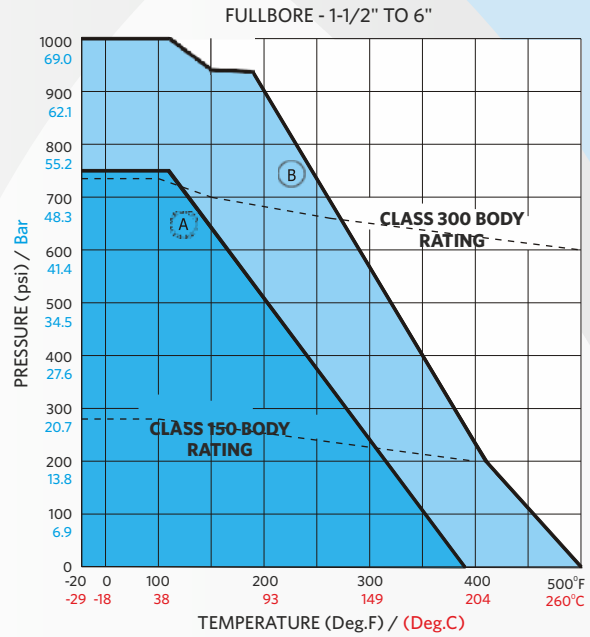
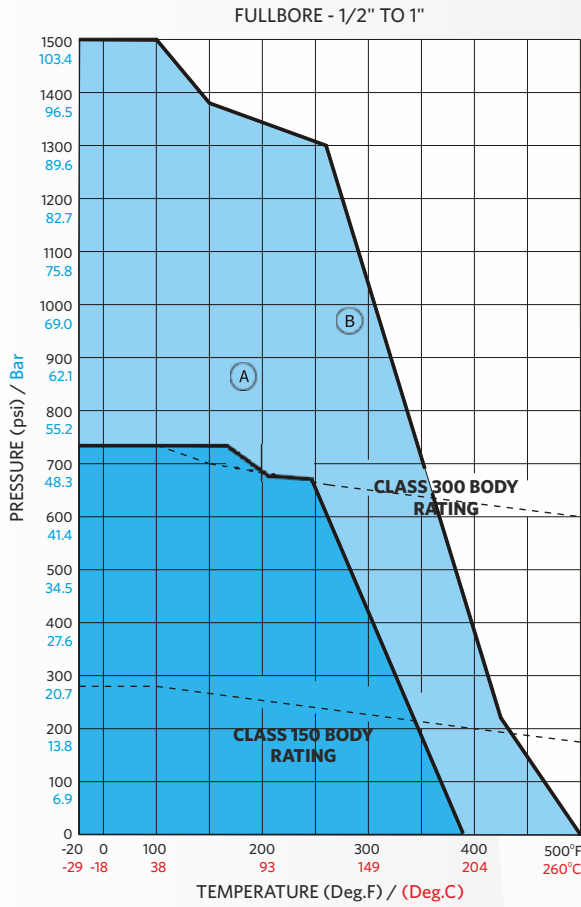

### TEMPERATURE LIMITS:

		Lower limit Deg.F/Deg.C		Upper limit Deg.F/Deg.C	
Body Matl.	WCB	-20	-29	800	425
	LCB	-50	-46	650	345
	CF8	-425	-254	1000	538
	CF8M	-425	-254	1000	538
Seat	FILLED & Virgin PTFE	-50	-46	As per Graph	

### SEAT MATERIAL:

A = Virgin PTFE, B = Filled PTFE

Pressure - temperature seat ratings of valves are as given in the graph for body material A 216 - WCB With the exception of body seat rings and primary soft seals, all valve components are capable of

withstanding the pressure - temperature rating as specified in ASME B 16.34, BS5351 as applicable.





# 2 PIECE SOFT SEATED FLOATING BALL VALVE

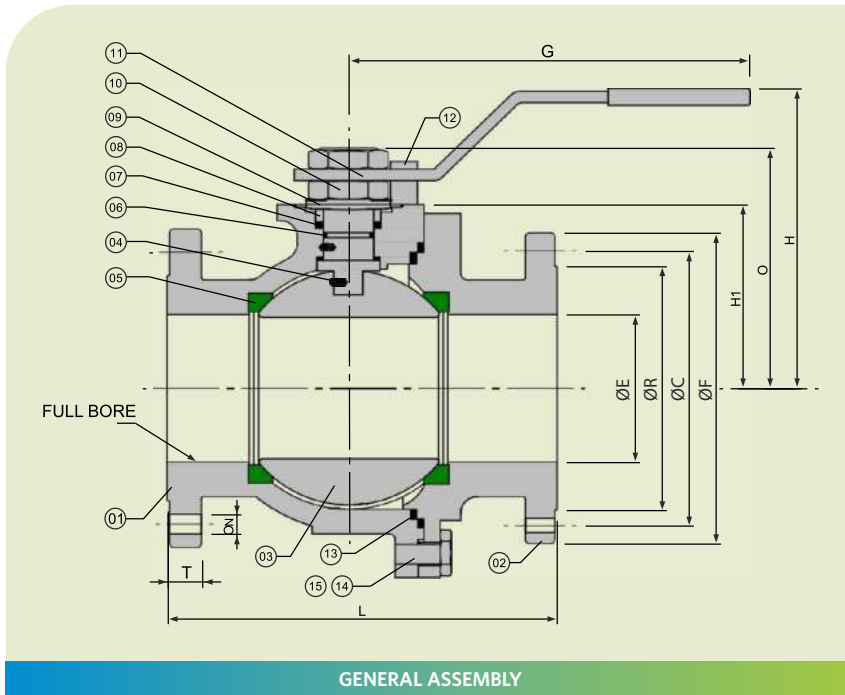

ITEM	PART NAME
01	BODY
02	BODY ADAPTER
03	BALL
04	STEM
05	SEAT
06	'O' RING
07	GASKET
08	SPACER
09	CUP SPRING
10	STEM NUT
11	HANDLE
12	STOP PIN
13	BODY GASKET
14	STUD
15	NUT
16	STEM BUSH
17	HANDLE COUPLER
18	PIPE
19	STOP & LOCK PLATE

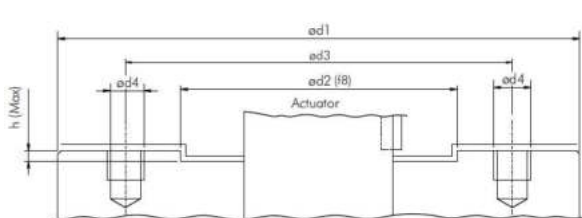
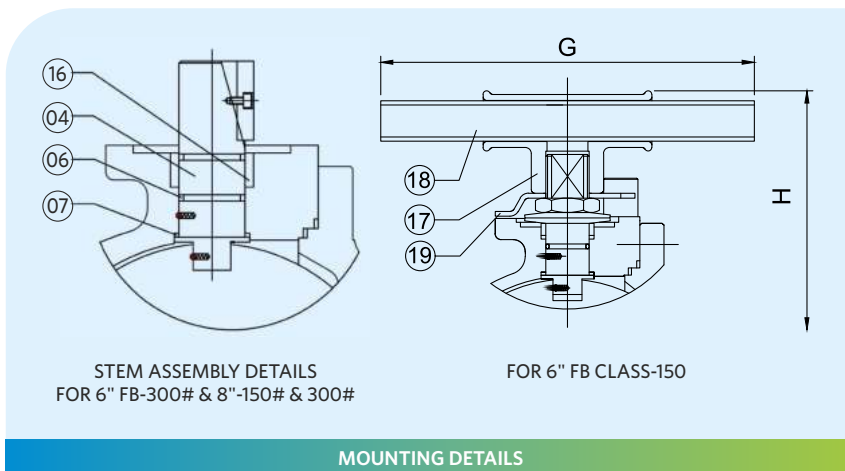

MOUNTING DETAILS OF ACTUATOR/GEAR OPERATOR AS PER ISO-5211

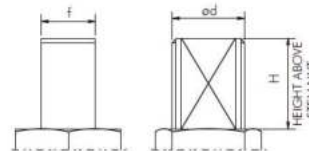

STEM END DETAILS FOR LEVER OPERATED VALVES

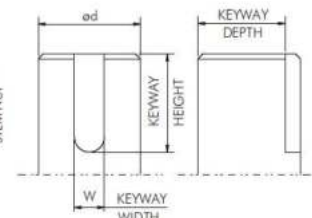

STEM END DETAILS FOR ACTUATOR/GEAR OPERATOR VALVE

## DIMENSIONAL DETAILS 2 PIECE SOFT SEATED FLOATING BALL VALVE

Dimensions (mm)

SIZE DN	15	20	25	40	50	65	80	100	150	200
CLASS	ASME 150 FULL BORE							(SP)	(LP)	
E	14	19	25	38	50	62	76	102	152	203
L	108.0	117.0	127.0	165.0	178	190.0	203	229	267	457.0
H	93	98	127	147	178	185	220	245	273	-
G	180	180	210	210	290	290	450	450	990	-
F	89	98.0	108.0	127.0	152.0	178	190	229	279.5	343.0
C	60.3	69.8	79.4	98.4	120.6	139.7	152.4	190.5	241.3	298.5
R	35	43	51	73	92	105	127	157	216	270
T	11.1	13	11.2	14.3	16.0	17.5	19.5	23.8	25.4	28.6
N	16	16	16	16	19	19	19	19	22	22
NO OF HOLES	4	4	4	4	4	4	4	8	8	8
O	50.5	55.5	66.5	92	105	114	138	160	222	274
H1	40	44	50	65	74	84	100	122	170	219
K	-	-	-	-	-	-	-	-	-	53
Z	-	-	-	-	-	-	-	-	-	350
ISO 5211 MTG	F05	F05	F05	F05	F07	F07	F10	F10	F12	F14
WT(Kg)	2.4	3.0	4.1	7.9	10.9	18.4	24.9	29.8	61.7	181.0
TORQUE (Nm)	5	8	12	25	30	46	56	145	350	800

SIZE DN	15	20	25	40	50	65	80	100	150	200
CLASS	ASME 300 FULL BORE							(SP)	(LP)	
E	14	19	25	38	50	62	76	102	152	203
L	140.5	152.0	165.0	190.0	216	241.0	283	305	403	419
H	93	98	127	147	178	185	220	245	-	-
G	180	180	210	210	290	290	450	450	-	-
F	95	117	124	156	165	190.5	210	254	318	381
C	66.7	83	89	114	127	149.2	168	200	270	330
R	35.0	43	51	73.0	92	105	127.0	157.0	216	270
T	14.3	15.8	17.5	20.6	22.4	25.4	28.6	32	36.5	41.3
N	16	19	19	22	19	22	22	22	22	25
NO OF HOLES	4	4	4	4	8	8	8	8	12	12
O	50.5	55.5	66.5	92	105	114	138	160	235.5	274
H1	40	44	50	65	74	84	100	122	180.5	219
K	-	-	-	-	-	-	-	-	53	53
Z	-	-	-	-	-	-	-	-	500	350
ISO 5211 MTG	F05	F05	F05	F05	F07	F07	F10	F10	F14	F14
WT(Kg)	3.2	4.5	5.8	10.8	14.9	24.9	33.8	44.8	114.4	208
TORQUE (Nm)	8	9	16	35	44	64	110	180	550	1000



## DIMENSIONAL DETAILS 2 PIECE SOFT SEATED FLOATING BALL VALVE

Dimensions (inches)

SIZE DN	1/2"	3/4"	1"	1-1/2"	2"	2-1/2"	3"	4"	6"	8"
CLASS	ASME 150 FULL BORE							(SP)	(LP)	
E	0.55	0.75	0.98	1.50	1.97	2.44	2.99	4.02	5.98	7.99
L	4.25	4.61	5.00	6.50	7.00	7.50	7.99	9.02	10.51	18.00
H	3.66	3.86	5.00	6.50	7.01	7.28	8.66	9.65	10.75	
G	7.09	7.09	8.27	8.27	11.42	11.42	17.72	17.72	38.98	
F	3.50	3.86	4.25	5.00	5.98	7.00	7.48	9.02	11.00	13.50
C	2.37	2.75	3.13	3.87	4.75	5.50	6.00	7.50	9.50	11.75
R	1.38	1.69	2.00	2.87	3.62	4.12	5.00	6.19	8.50	10.62
T	0.44	0.51	0.44	0.56	0.62	0.69	0.75	0.94	1.00	1.13
N	0.62	0.62	0.62	0.62	0.75	0.75	0.75	0.75	0.88	0.88
NO OF HOLES	4	4	4	4	4	4	4	8	8	8
O	1.99	2.19	2.62	3.63	4.14	4.48	5.44	6.28	8.73	10.79
H1	1.58	1.73	1.97	2.56	2.91	3.31	3.94	4.80	6.69	8.62
K	-	-	-	-	-	-	-	-	-	2.09
Z	-	-	-	-	-	-	-	-	-	13.78
ISO 5211 MTG	F05	F05	F05	F05	F07	F07	F10	F10	F12	F14
WT(lbs.)	5.30	6.63	9.06	17.46	24.31	40.89	55.25	66.30	152.00	361.34
TORQUE (in-lbs.)	44	71	106	221	266	407	496	1283	3098	7080

SIZE DN	1/2"	3/4"	1"	1-1/2"	2"	2-1/2"	3"	4"	6"	8"
CLASS	ASME 300 FULL BORE							(SP)	(LP)	
E	0.55	0.75	0.98	1.50	1.97	2.44	2.99	4.02	5.98	7.99
L	5.53	5.98	6.50	7.48	8.50	9.50	11.14	12.00	15.88	16.50
H	3.66	3.86	5.00	5.79	7.01	7.28	8.66	9.65	-	-
G	7.09	7.09	8.27	8.27	11.42	11.42	17.72	17.72	-	-
F	3.75	4.62	4.88	6.14	6.50	7.50	8.25	10.00	12.50	15.00
C	2.63	3.25	3.50	4.50	5.00	5.88	6.62	7.88	10.62	13.00
R	1.38	1.69	2.00	2.88	3.62	4.12	5.00	6.18	8.50	10.62
T	0.56	0.62	0.69	0.81	0.88	1.00	1.13	1.26	1.44	1.63
N	0.62	0.75	0.75	0.88	0.75	0.88	0.88	0.88	0.88	1.00
NO OF HOLES	4	4	4	4	8	8	8	8	12	12
O	1.99	2.19	2.62	3.63	4.14	4.48	5.44	6.28	9.27	10.79
H1	1.58	1.73	1.97	2.56	2.91	3.31	3.94	4.80	7.11	8.62
K	-	-	-	-	-	-	-	-	2.09	2.09
Z	-	-	-	-	-	-	-	-	19.69	13.78
ISO 5211 MTG	F05	F05	F05	F05	F07	F07	F10	F10	F14	F14
WT(lbs.)	7.07	9.95	12.82	24.09	33.15	55.25	75.14	99.45	254.15	397.80
TORQUE (in-lbs.)	71	80	142	310	390	567	974	1593	4868	8851



# VALVE OPERATION AND OPERATOR MOUNTING DETAILS

## VALVE OPERATION:

IPC offers an option of operating the valve by hand lever, gear operator or actuator. Length of lever and diameter of handwheel (maximum 31-1/2") of gear operator are designed to keep operating force less

than 80 lb. All valves have a stopper for fully opened and closed position along with indicator to show position of ball port.



SWITCH BOX



ACTUATOR OPERATED

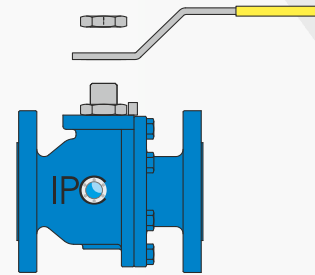

LEVER OPERATED

## Dimensions (mm)

SIZE	ISO PAD DETAILS												
	ISO 5211 FLANGE	d1	d2-f8	d3	d4	h-max	NO. OF STUDS	DIA. (d)	A/F(f)	HEIGHT ABOVE STEM NUT(H)	KEY-WAY DEPTH	KEY-WAY WIDTH	KEY-WAY LENGTH
CLASS 150/300		mm	mm	mm	UNC	mm		mm	mm	mm	mm	mm	mm
DN15	F05	65	35	50	1/4"	3	4	12	8	8.8	-	-	-
DN20	F05	65	35	50	1/4"	3	4	12	8	8.8	-	-	-
DN25	F05	65	35	50	1/4"	3	4	16	10	14.3	-	-	-
DN40	F05	65	35	50	1/4"	3	4	16	10	22.3	-	-	-
DN50	F07	90	55	70	5/16"	3	4	20	14	22.8	-	-	-
DN65	F07	90	55	70	5/16"	3	4	20	14	22.8	-	-	-
DN80	F10	125	70	102	3/8"	3	4	28	20	27.8	-	-	-
DN100	F10	125	70	102	3/8"	3	4	28	20	27.8	-	-	-
DN150 #150	F12	150	85	125	1/2"	8.5	4	36	24	35.0	-	-	-
DN150 #300	F14	175	100	140	5/8"	5	4	42	-	-	37	12	53
DN200 #150	F14	175	100	140	5/8"	5	4	42	-	-	37	12	53
DN200 #300	F14	175	100	140	5/8"	5	4	42	-	-	37	12	53

## Dimensions (inches)

SIZE	ISO PAD DETAILS												
	ISO 5211 FLANGE	d1	d2-f8	d3	d4	h-max	NO. OF STUDS	DIA. (d)	A/F(f)	HEIGHT ABOVE STEM NUT(H)	KEY-WAY DEPTH	KEY-WAY WIDTH	KEY-WAY LENGTH
CLASS 150/300		inch	inch	inch	UNC	inch		inch	inch	inch	inch	inch	inch
1/2"	F05	2.56	1.38	1.97	1/4"	0.12	4.00	0.47	0.31	0.35	-	-	-
3/4"	F05	2.56	1.38	1.97	1/4"	0.12	4.00	0.47	0.31	0.35	-	-	-
1"	F05	2.56	1.38	1.97	1/4"	0.12	4.00	0.63	0.39	0.56	-	-	-
1-1/2"	F05	2.56	1.38	1.97	1/4"	0.12	4.00	0.63	0.39	0.88	-	-	-
2"	F07	3.54	2.17	2.76	5/16"	0.12	4.00	0.79	0.55	0.90	-	-	-
2-1/2"	F07	3.54	2.17	2.76	5/16"	0.12	4.00	0.79	0.55	0.90	-	-	-
3"	F10	4.92	2.76	4.02	3/8"	0.12	4.00	1.10	0.79	1.09	-	-	-
4"	F10	4.92	2.76	4.02	3/8"	0.12	4.00	1.10	0.79	1.09	-	-	-
6" #150	F12	5.91	3.35	4.92	1/2"	0.34	4.00	1.42	0.94	1.38	-	-	-
6" #300	F14	6.89	3.94	5.51	5/8"	0.20	4.00	1.65	-	-	1.44	0.47	2.09
8" #150	F14	6.89	3.94	5.51	5/8"	0.20	4.00	1.65	-	-	1.44	0.47	2.09
8" #300	F14	6.89	3.94	5.51	5/8"	0.20	4.00	1.65	-	-	1.44	0.47	2.09



# TWO PIECE BALL VALVE 600#

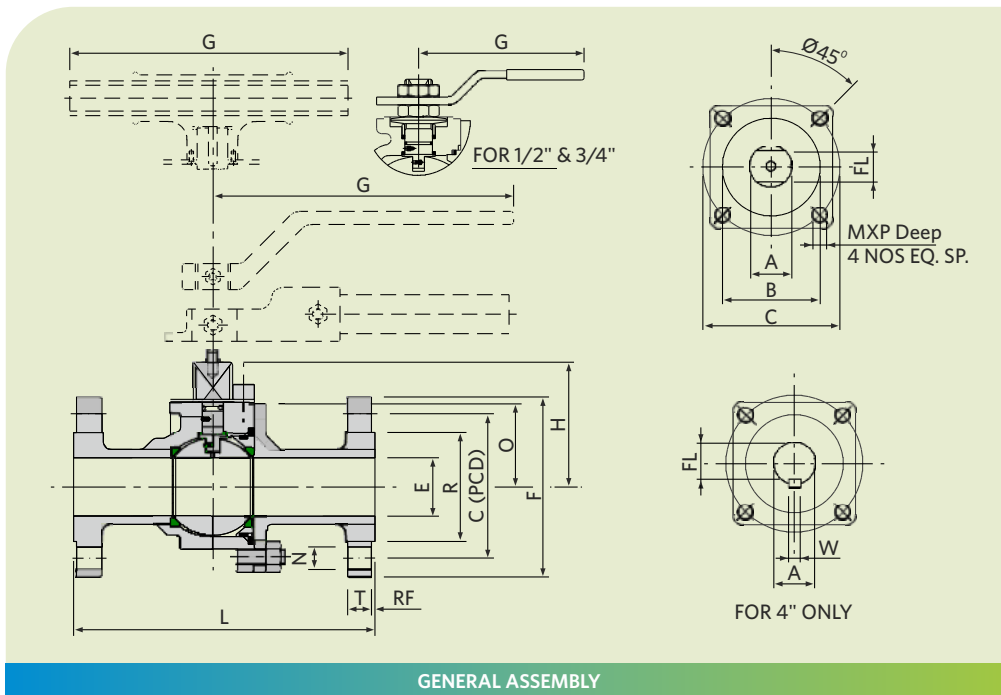

Dimensions (mm)

ASME 600 FULL BORE							
SIZE	DN15	DN20	DN25	DN40	DN50	DN80	DN100
E	0.55	0.75	0.98	1.50	1.97	2.99	4.02
L	165.0	190.5	216.0	241.3	292.0	355.6	432.0
H	67.0	67.0	66.0	91.0	106.0	147.0	184.0
G	212.0	212.0	205.0	275.0	455.0	692.0	990.0
F	95.3	117.6	124.0	155.4	165.0	209.6	273.0
C	66.5	83.0	89.0	114.3	127.0	168.0	216.0
R	35.0	43.0	51.0	73.0	92.0	127.0	157.0
T	14.2	15.7	17.5	22.4	25.4	32.0	38.0
N	16.0	19.0	19.0	22.0	19.0	22.0	25.4
NO. OF HOLES	4	4	4	4	8	8	8
O	48.0	48.0	48.0	63.0	72.5	108.0	125.0
ISO 5211 MTG	F05	F05	F05	F05	F07	F10	F14
A	16.0	16.0	20.0	24.0	26.0	34.0	42.0
B	35.0	35.0	35.0	35.0	55.0	70.0	100.0
C	50.0	50.0	50.0	50.0	70.0	102.0	140.0
FL	10.0	10.0	14.0	18.0	20.0	26.4	37.0
M UNC x P	1/4" x 10	1/4" x 10	1/4" x 8.0	1/4" x 8.0	5/16" x 13.0	3/8" x 15.0	5/8" x 18.0
WT(Kg)	4.2	4.5	7.0	14.0	17.0	39.0	80.0
TORQUE (Nm)	26	30	66	100	134	304	500

NOTE: RF FOR 600# = 6.4 mm. FOR 4" SIZE W x K= 12 x 55

Dimensions (inches)

ASME 600 FULL BORE							
SIZE	1/2"	3/4"	1"	1-1/2"	2"	3"	4"
E	0.55	0.75	0.98	1.50	1.97	2.99	4.02
L	6.5	7.5	8.5	9.5	11.5	14.0	17.0
H	2.64	2.64	2.61	3.58	4.17	5.77	7.24
G	8.35	8.35	8.07	10.8	17.91	27.24	38.98
F	3.75	4.63	4.88	6.12	6.50	8.25	10.75
C	2.62	3.27	3.50	4.50	5.00	6.62	8.50
R	1.38	1.69	2.00	2.88	3.62	5.00	6.18
T	0.56	0.62	0.69	0.88	1.00	1.26	1.50
N	0.63	0.75	0.75	0.88	0.75	0.88	1.00
NO. OF HOLES	4	4	4	4	8	8	8
O	1.89	1.89	1.89	2.48	2.85	4.25	4.92
ISO 5211 MTG	F05	F05	F05	F05	F07	F10	F14
A	0.63	0.63	0.79	0.94	1.02	1.34	1.65
B	1.38	1.38	1.38	1.38	2.17	2.76	3.94
C	1.97	1.97	1.97	1.97	2.76	4.02	5.51
FL	0.39	0.39	0.55	0.71	0.79	1.04	1.46
M UNC x P	1/4" x 0.39	1/4" x 0.39	1/4" x 0.31	1/4" x 0.31	5/16" x 0.51	3/8" x 0.59	5/8" x 0.71
WT (lbs)	9.26	9.9	15.5	31.0	37.5	86.0	176.4
TORQUE (in-lbs)	230	266	584	885	1186	2691	4425

NOTE : RF FOR 600# = 0.25". FOR 4" SIZE W x K= 0.47 X 2.17"



# THREE PIECE BALL VALVE 400#

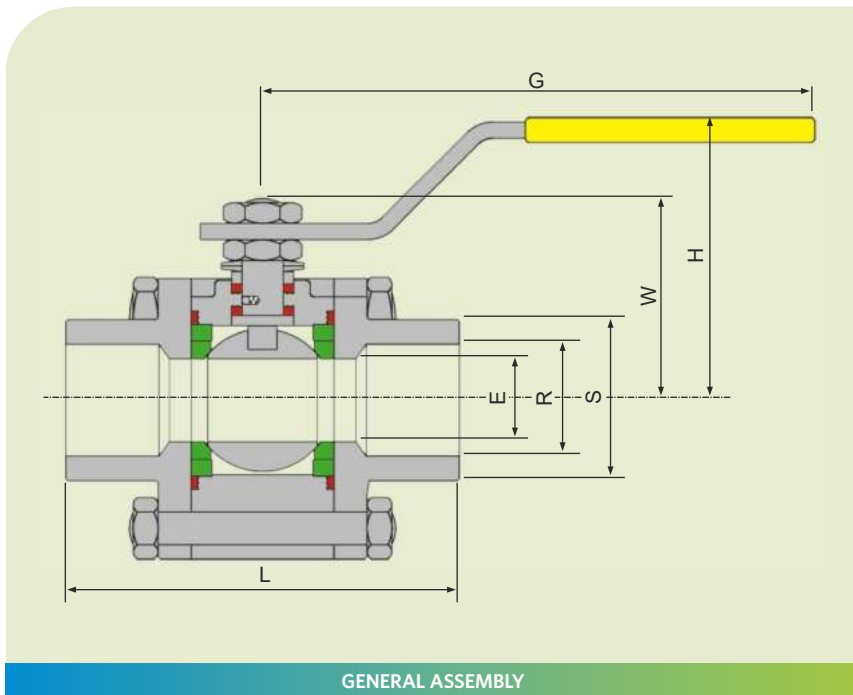

Dimensions (mm)

SIZE	DN15	DN20	DN25	DN32	DN40	DN50
	FB	FB	FB	FB	FB	FB
CLASS	ASME 400 FULL BORE					
E	14	19	25	32	38	50
R	21.8	27.4	34.1	42.7	49.0	61.0
S	30.0	36.0	46.0	56	60.5	74
L	66.5	80.5	95.5	111.5	103.5	124.5
G	120	120	200	200	250	250
H	73	83	83.5	88	108.0	118.0
M	42.5	47.0	56.4	61.5	70.5	85.5
WT(Kg)SCRD	1.97	2.78	4.76	6.75	9.42	13.99
WT(Kg)SW	1.97	2.78	4.76	7.44	8.73	13.59
TORQUE(Nm)	8	9	16	25	35	44

Dimensions (inches)

SIZE	1/2"	3/4"	1"	1-1/4"	1-1/2"	2"
	FB	FB	FB	FB	FB	FB
<b>CLASS</b>	<b>ASME 400 FULL BORE</b>					
E	0.55	0.75	0.984	1.25	1.50	1.97
R	0.86	1.08	1.34	1.68	1.93	2.40
S	1.18	1.42	1.81	2.20	2.38	2.91
L	2.62	3.17	3.76	4.37	4.07	4.88
G	4.72	4.72	7.87	7.87	9.84	9.84
H	2.87	3.27	3.29	3.46	4.25	4.65
M	1.67	1.85	2.22	2.42	2.78	3.37
WT (lbs.)SCRD	4.37	6.17	10.58	14.99	20.94	31.08
WT (lbs.) SW	4.37	6.17	10.58	16.53	19.40	30.20
TORQUE (in-lbs.)	71	80	142	221	310	390

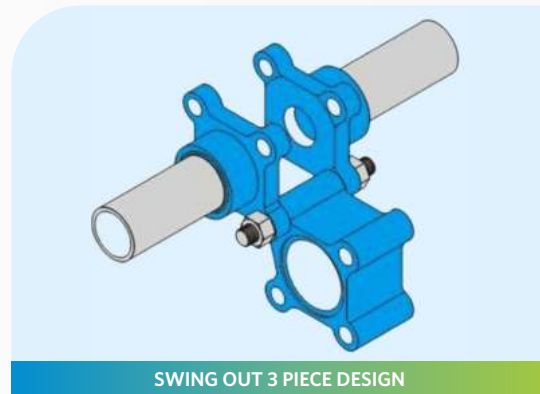

- Three-piece design is compact and is available with a variety of pipe ends like screwed, socket weld or butt weld.
- Fully enclosed bolting
- Superior performance characteristics with fast and economical in-line maintenance
- Simple for installation and easy for maintenance
- Seats, seals and ball can be replaced quickly without disturbing pipe alignment



# MATERIAL OF CONSTRUCTION AND VALVES QUALIFYING FIRE TEST

PART	MATERIAL OPTIONS
BODY	ASTM - A 216 WCB / A351 CF8 / A 351 CF8M / A 351 CF3 / A 351 CF3M / A 352 LCB
BODY ADAPTER	ASTM - A 216 WCB / A351 CF8 / A 351 CF8M / A 351 CF3 / A 351 CF3M / A 352 LCB
BALL	ASTM - A 351 CF8 / A 351 CF8M / A 351 CF3 / A 351 CF3M
STEM	ASTM - A479 SS304 / A479 SS316 / A479 SS304L / A479 SS316L / A182 F304 / A182 F316 / A564 17-4PH
SEAT	VIRGIN PTFE / RPTFE / NYLON / PEEK / DELRIN / PCTFE / CFT / DEVLON
O RING	VITON / CHEMRAZ <sup>®</sup> 605
STEM GASKET	VIRGIN PTFE / RPTFE / GRAPHITE
SPACER	ASTM - A 479 SS316
CUP SPRING	ASTM - A 479 SS304 / 51 CrV4
STEM NUT	ASTM - A 194 GR7 / A 194 GR8 / A 194 GR8M / A 194 2H / A 194 2HM
HANDLE	MS (ZINC PLATED) / SS304 / SS316
STOP PIN	ASTM - A 479 SS316 / MS
BODY GASKET	VIRGIN PTFE / RPTFE / GRAPHITE
STUDS / BOLTS	ASTM - A 320 L7 / A 193 B8 / A 193 B8M / A 193 B7 / A 193 B7M
NUT	ASTM - A 194 GR7 / A 194 GR8 / A 194 GR8M / A 194 2H / A 194 GR. 2HM
STEM BUSH	PHOSPHOR BRONZE
STEM HOUSING	ASTM - A 216 WCB / A351 CF8 / A 351 CF8M / A 351 CF3 / A 351 CF3M / A 352 LCB

- Materials not listed above can be offered on request

## FIRE TEST

Ball Valves have been designed to meet the requirements of API 607 (Seventh Edition)





# ORDERING INFORMATION

1	2	3	4	5	6	7	8	9	10	11	12
DESIGN	CONSTRUCTION	END CONNECTION	RATING	BORE	BODY	BALL	SEAT/SEAT INSERT	FIRE SAFETY	OPERATION	PATTERN	SPECIAL REQ.
401	2	RF	1	F	C	C	T	F	B	S	XX

**1 DESIGN**

401	FLOATING BALL VALVE FIRE SAFE
402	FLOATING BALL VALVE FIRE SAFE AND SIL CERTIFIED

**2 CONSTRUCTION**

2	TWO PIECE
3	THREE PIECE

**3 END CONNECTION & FINISH**

RF	FLANGED RAISED FACE SERRATED
RS	FLANGED RAISED FACE SMOOTH
FF	FLANGED FLAT FACE SERRATED
FS	FLANGED FLAT FACE SMOOTH
RT	FLANGED RTJ
SW	SOCKET WELD
SN	SOCKET WELD WITH 4" NIPPLE EXTENSION
BS	SCREWED BSP
NP	SCREWED NPT
BW	BUTT WELD

**4 RATING**

1	150#
3	300#
4	400#
6	600#
8	800#

**5 BORE**

F	FULL BORE
---	-----------

**6 BODY**

C	WCB
1	A105
L	LCB / LCC
4	CF8/SS304
6	CF8M / SS316
3	CF3 / SS304L
5	CF3M / SS316L
M	MONEL
H	HASTELLOY
A	ALLOY 20
0	OTHER THAN ABOVE

**7 BALL**

C	WCB
1	A105
L	LCB
4	CF8/SS304
6	CF8M / SS316
3	CF3 / SS304L
5	CF3M / SS316L
M	MONEL
H	HASTELLOY
A	ALLOY 20
O	OTHER THAN ABOVE

**8 SEAT/SEAT INSERT**

T	RPTFE
G	GFT
C	CFT
F	CGFT
P	PEEK
E	PCTFE
L	DEVLON

**9 FIRE SAFETY**

F	FIRE SAFE
N	NON FIRE SAFE

**10 OPERATION**

B	BARE STEM
G	GEAR OPERATED
L	HANDLEVER
A	ACTUATED

**11 PATTERN**

SP	SHORT PATTERN
LP	LONG PATTERN

**12 SPECIAL REQ.**

XX	SPECIAL REQUIREMENTS TO BE SPECIFIED
----	--------------------------------------

## EXAMPLE

402	2	RF	1	F	C	6	T	S	L	SP	XX
-----	---	----	---	---	---	---	---	---	---	----	----

This code stands for Floating ball valve, Two piece with flanged raised face serrated end connection, 150#, full bore, WCB body, CF8M/SS 316 ball, PTFE seat, Non fire safe, Hand-lever operation, short pattern and with special req. to be specified.

TRUSTED BY THE LEADERS



**Integral Process Controls India Pvt. Ltd.**

**Registered Office**

W-55, S Block, MIDC, Bhosari, Pune - 411026,  
Maharashtra, India.

**Works - Valve Automation Division**

Plot No. 43, Sector 10, PCNTDA,, Bhosari,  
Pune - 411026, Maharashtra, India.

☎ +91 20 63103900 (30 Lines)

✉ sales.ipc@ipcvalves.com

🌐 www.ipcvalves.com

CIN: U29120PN2010PTC136972



Visit Website